

TWMMC

EQ7 *AC Drive Series*

INSTRUCTION MANUAL

Available Documentation:

1. EQ7 Quick Setting Guide - Print Copy
2. EQ7 Instruction Manual - Print Copy
3. EQ7 User Manual - PDF - Visit our website at www.tecowestinghouse.com

Variable Torque 0.5 - 1000HP

Constant Torque 0.5 - 900 HP

- Read all operating instructions before installing, connecting (wiring), operating, servicing, or inspecting the inverter.
- Ensure that the instruction manual is made available to the end user of the inverter.
- This instruction manual is subject to change without prior notice.

Preface

The EQ7 product is designed to drive a three-phase induction motor. Read through this instruction manual to become familiar with proper handling and correct use. Improper handling might result in incorrect operation, shorter life cycle, or failure of this product as well as the motor.

Have this Instruction Manual delivered to the end user of this product. Keep this Instruction Manual in a safe place accessible by only people in connection with the VFD until this product is no longer being used.

Read this Instruction Manual in conjunction with EQ7 User Manual.

All EQ7 documentation is subject to change without notice



Available Documentation:

1. EQ7 Quick Setting Guide
2. EQ7 Instruction Manual
3. EQ7 User Manual

Safety Precautions

Read this instruction manual thoroughly before proceeding with installation, connections (wiring), operation, or maintenance and inspection. Ensure you have sound knowledge of the device and familiarize yourself with all safety information and precautions before proceeding to operate the inverter.

Safety precautions are classified into the following two categories in this manual.

 WARNING	Failure to heed the information indicated by this symbol may lead to dangerous conditions, possibly resulting in death or serious bodily injuries.
 CAUTION	Failure to heed the information indicated by this symbol may lead to dangerous conditions, possibly resulting in minor or light bodily injuries and/or substantial property damage.

Failure to ignore the information contained under the CAUTION title can also result in serious consequences. These safety precautions are of utmost importance and must be observed at all times.

Icons

The following icons are used throughout this quick start manual.



-  This icon indicates information which, if not followed, can result in the inverter not operating to full efficiency, as well as information concerning incorrect operations and settings which can result in accidents.
-  This icon indicates information that can prove handy when performing certain settings or operations.
-  This icon indicates a reference to more detailed information.

Table of Contents

Safety and Conformity	iv
Application	iv
Installation.....	iv
Wiring.....	v
Operation	vi
Maintenance, Inspection and Part Replacements.....	vii
Conformity with UL standards and CSA standards (cUL –listed for Canada).....	viii
1. Drive Model Identification, Installation and Wiring Practices	1-1
1.1 Drive Models Constant Torque (CT) / Variable Torque (VT) HP Ratings	1-2
1.2 Installation and wiring practices.....	1-3
1.3 Precautions in running Inverters.....	1-11
1.4 Precautions in using special motors	1-11
2. Mounting and Wiring the Inverter.....	2-1
2.1 Operating Environment.....	2-1
2.2 Installing the Inverter	2-1
2.3 Wiring.....	2-4
2.4 Mounting and Connecting the Keypad	2-27
2.5 Input Power and Motor Connection	2-28
3. Operation using the Keypad.....	3-1
3.1 LED Monitor, LCD Monitor, and Keys	3-1
3.2 Overview of Operating Modes	3-3
3.3 Running Mode	3-4
3.4 Programming Mode	3-8
4. Function Codes / Parameters	4-1
4.1 Function Code Tables	4-1
4.2 Details of Function Codes	4-25
5. Check Motor Rotation and Direction.....	5-1
6. Speed Reference Command Configuration.....	6-1
6.1 Reference from the Keypad.....	6-1
6.2 Reference from an Analog Signal (0-10V / 4-20mA) / Speed Pot.....	6-2
6.3 Reference from Serial Communication – RS485	6-4

7. Operation Method Configuration (Run / Stop)	7-1
7.1 Run / Stop from the Keypad	7-1
7.2 Run / Stop from External Switch / Contact or Pushbutton	7-2
7.3 Run / Stop from Serial Communication – RS485	7-4
8. Motor and Application Specific Settings	8-1
8.1 Set Motor Nameplate Data	8-1
8.2 Acceleration and Deceleration Time.....	8-2
8.3 Torque Boost Setting.....	8-3
8.3 Load Selection / Auto Torque Boost / Auto Energy Saving Operation.....	8-4
8.4 Reset EQ7 back to Factory Default	8-6
9. Using PID Control for Constant Flow / Pressure Applications	9-1
9.1 What is PID Control	9-1
9.2 Connect Transducer Feedback Signal	9-2
9.3 Setpoint Scaling / Transducer Feedback Scaling.....	9-4
10. Troubleshooting	10-1
10.1 Protective Functions	10-1
10.2 Before Proceeding with Troubleshooting	10-2
10.3 If Neither an Alarm Nor “Light Alarm” Indication(<i>L - AL</i>) Appears on the LED Monitor.....	10-5
10.4 If an Alarm Code Appears on the LED Monitor	10-12
10.5 If the “Light Alarm” Indication (<i>L - AL</i>) Appears on the LED Monitor	10-25
10.6 If an Abnormal Pattern Appears on the LED Monitor	10-26
10.7 If the inverter is running on Single-Phase Power	10-27
11. Specifications	11-1
11.1 Drive Ratings	11-1
11.2 Common Specifications	11-7
11.3 External Dimensions, Drive, Panel Cutting, DCR, Keypad	11-12

Application

WARNING

- The EQ7 drive is designed to drive a three-phase induction motor. Do not use it for single-phase motors or for other purposes.
Fire or an accident could occur.
- The EQ7 drive may not be used for a life-support system or other purposes directly related to the human safety.
- Though the EQ7 drive is manufactured under strict quality control, install safety devices for applications where serious accidents or property damages are foreseen in relation to the failure of it.
An accident could occur.

Installation

WARNING

- Install the inverter on a base made of metal or other non-flammable material.
Otherwise, a fire could occur.
- Do not place flammable object nearby.
Doing so could cause fire.
- Inverters with a capacity of 50 HP or above, whose protective structure is IP00 (Open Chassis), involve a possibility that a human body may touch the live conductors of the main circuit terminal block. Inverters to which an optional DC reactor is connected also involve the same. Install such inverters in an inaccessible place.
Otherwise, electric shock or injuries could occur.

CAUTION

- Do not support the inverter by its front cover during transportation.
Doing so could cause a drop of the inverter and injuries.
- Prevent lint, paper fibers, sawdust, dust, metallic chips, or other foreign materials from getting into the inverter or from accumulating on the heat sink.
- When changing the positions of the top and bottom mounting bases, use only the specified screws.
Otherwise, a fire or an accident might result.
- Do not install or operate an inverter that is damaged or lacking parts.
Doing so could cause fire, an accident or injuries.

Wiring

WARNING

- If no zero-phase current (earth leakage current) detective device such as a ground-fault relay is installed in the upstream power supply line in order to avoid the entire power supply system's shutdown undesirable to factory operation, install a residual-current-operated protective device (RCD)/earth leakage circuit breaker (ELCB) individually to inverters to break the individual inverter power supply lines only.

Otherwise, a fire could occur.

- When wiring the inverter to the power source, insert a recommended molded case circuit breaker (MCCB) or residual-current-operated protective device (RCD)/earth leakage circuit breaker (ELCB) (with overcurrent protection) in the path of each pair of power lines to inverters. Use the recommended devices within the recommended current capacity.
- Use wires of the specified size.
- Tighten terminals with specified torque.

Otherwise, a fire could occur.

- When there is more than one combination of an inverter and motor, do not use a multi-conductor cable for the purpose of running the leads together.
- Do not connect a surge absorber to the inverter's output (secondary) circuit.

Doing so could cause a fire.

- Be sure to connect an optional DC reactor (DCR) when the capacity of the power supply transformer exceeds 500 kVA and is 10 times or more the inverter rated capacity.

Otherwise, a fire could occur.

- Ground the inverter in compliance with the national or local electric code.
- Be sure to ground the inverter's grounding terminals .

Otherwise, an electric shock or a fire could occur.

- Qualified electricians should carry out wiring.
- Be sure to perform wiring after turning the power OFF.

Otherwise, an electric shock could occur.

- Be sure to perform wiring after installing the inverter unit.

Otherwise, an electric shock or injuries could occur.

- Ensure that the number of input phases and the rated voltage of the product match the number of phases and the voltage of the AC power supply to which the product is to be connected.

Otherwise, a fire or an accident could occur.

- Do not connect the power supply wires to output terminals (U, V, and W).
- When connecting a DC braking resistor (DBR), never connect it to terminals other than terminals P(+) and DB.

Doing so could cause fire or an accident.

- In general, the insulation of the control signal wires are not specifically designed to withstand a high voltage (i.e., reinforced insulation is not applied). Therefore, if a control signal wire comes into direct contact with a live conductor of the main circuit, the insulation may break down, which would expose the signal wire to the high voltage of the main circuit. Make sure that the control signal wires will not come into contact with live conductors of the main circuit.

Doing so could cause an accident or an electric shock.

⚠ WARNING ⚠

- Before changing the switches or touching the control circuit terminal symbol plate, **turn OFF the power and wait at least five minutes for inverters of 40 HP or below, or at least ten minutes for inverters of 50 HP or above.** Make sure that the LED monitor and charging lamp are turned OFF. Further, make sure, using a multimeter or a similar instrument, that the DC link bus voltage between the terminals P(+) and N(-) has dropped to the safe level (+25 VDC or below).

Otherwise, an electric shock could occur.

⚠ CAUTION ⚠

- The inverter, motor and wiring generate electric noise. This may cause the malfunction of nearby sensors and devices. To prevent malfunctioning, implement noise control measures.

Otherwise an accident could occur.

Operation

⚠ WARNING ⚠

- Be sure to mount the front cover before turning the power ON. Do not remove the cover when the inverter power is ON.
Otherwise, an electric shock could occur.
- Do not operate switches with wet hands.
Doing so could cause electric shock.
- If the auto-reset function has been selected, the inverter may automatically restart and drive the motor depending on the cause of tripping. Design the machinery or equipment so that human safety is ensured at the time of restarting.
Otherwise, an accident could occur.
- If the stall prevention function (current limiter), automatic deceleration (anti-regenerative control), or overload prevention control has been selected, the inverter may operate with acceleration/deceleration or frequency different from the commanded ones. Design the machine so that safety is ensured even in such cases.
- If any of the protective functions have been activated, first remove the cause. Then, after checking that the all run commands are set to OFF, release the alarm. If the alarm is released while any run commands are set to ON, the inverter may supply the power to the motor, running the motor.
Otherwise, an accident could occur.
- If you enable the "Restart mode after momentary power failure" (Function code F14 = 3 to 5), then the inverter automatically restarts running the motor when the power is recovered. Design the machinery or equipment so that human safety is ensured after restarting.
- If the user configures the function codes wrongly without completely understanding this Instruction Manual and the EQ7 DRIVE User's Manual, the motor may rotate with a torque or at a speed not permitted for the machine.
An accident or injuries could occur.
- Even if the inverter has interrupted power to the motor, if the voltage is applied to the main circuit input terminals L1/R, L2/S and L3/T, voltage may be output to inverter output terminals U, V, and W.
- Even if the run command is set to OFF, voltage is output to inverter output terminals U, V, and W if the servo-lock command is ON.
- Even if the motor is stopped due to DC braking or preliminary excitation, voltage is output to inverter output terminals U, V, and W.
An electric shock may occur.
- The inverter can easily accept high-speed operation. When changing the speed setting, carefully check the specifications of motors or equipment beforehand.
Otherwise, injuries could occur.

⚠ CAUTION

- Do not touch the heat sink and braking resistor because they become very hot.
Doing so could cause burns.
- The DC brake function of the inverter does not provide any holding mechanism.
Injuries could occur.
- Ensure safety before modifying the function code settings.
Run commands (e.g., "Run forward" **FWD**), stop commands (e.g., "Coast to a stop" **BX**), and frequency change commands can be assigned to digital input terminals. Depending upon the assignment states of those terminals, modifying the function code setting may cause a sudden motor start or an abrupt change in speed.
- When the inverter is controlled with the digital input signals, switching run or frequency command sources with the related terminal commands (e.g., **SS1, SS2, SS4, SS8, Hz2/Hz1, Hz/PID, IVS**, and **LE**) may cause a sudden motor start or an abrupt change in speed.
- Ensure safety before modifying customizable logic related function code settings (U codes and related function codes) or turning ON the "Cancel customizable logic" terminal command **CLC**. Depending upon the settings, such modification or cancellation of the customizable logic may change the operation sequence to cause a sudden motor start or an unexpected motor operation.
An accident or injuries could occur.

Maintenance, inspection and parts replacement

⚠ WARNING ⚠

- Before proceeding to the maintenance/inspection jobs, **turn OFF the power and wait at least five minutes for inverters of 40 HP or below, or at least ten minutes for inverters of 50 HP or above.** Make sure that the LED monitor and charging lamp are turned OFF. Further, make sure, using a multimeter or a similar instrument, that the DC link bus voltage between the terminals P(+) and N(-) has dropped to the safe level (+25 VDC or below).
Otherwise, an electric shock could occur.
- Maintenance, inspection, and parts replacement should be made only by qualified persons.
- Take off the watch, rings and other metallic objects before starting work.
- Use insulated tools.
Otherwise, an electric shock or injuries could occur.
- Never modify the inverter.
Doing so could cause an electric shock or injuries.

Disposal

⚠ CAUTION

- Treat the inverter as an industrial waste when disposing of it.
Otherwise injuries could occur.

GENERAL PRECAUTIONS

Drawings in this manual may be illustrated without covers or safety shields for explanation of detail parts. Restore the covers and shields in the original state and observe the description in the manual before starting operation.

Conformity with UL standards and CSA standards (cUL-listed for Canada)

UL/cUL-listed inverters are subject to the regulations set forth by the UL standards and CSA standards (cUL-listed for Canada) by installation within precautions listed below.

⚠ CAUTION

1. Solid state motor overload protection (motor protection by electronic thermal overload relay) is provided in each model.
Use function codes F10 to F12 to set the protection level.
2. Use Cu wire only.
3. Use Class 1 wire only for control circuits.
4. Short circuit rating
"Suitable For Use On A Circuit Of Delivering Not More Than 100,000 rms Symmetrical Amperes, 240 Volts Maximum for 230 V class input 40 HP or below, 230 Volts maximum for 230 V class input 50 HP or above when protected by Class J Fuses or a Circuit Breaker having an interrupting rating not less than 100,000 rms Symmetrical Amperes, 240 Volts Maximum." Models FRN; rated for 230 V class input.
"Suitable For Use On A Circuit Of Delivering Not More Than 100,000 rms Symmetrical Amperes, 480 Volts Maximum when protected by Class J Fuses or a Circuit Breaker having an interrupting rating not less than 100,000 rms Symmetrical Amperes, 480 Volts Maximum." Models FRN; rated for 460 V class input.
"Integral solid state short circuit protection does not provide branch circuit protection. Branch circuit protection must be provided in accordance with the National Electrical Code and any additional local codes."
5. Field wiring connections must be made by a UL Listed and CSA Certified closed-loop terminal connector sized for the wire gauge involved. Connector must be fixed using the crimp tool specified by the connector manufacturer.
6. All circuits with terminals L1/R, L2/S, L3/T, R0, T0, R1, T1 must have a common disconnect and be connected to the same pole of the disconnect if the terminals are connected to the power supply.

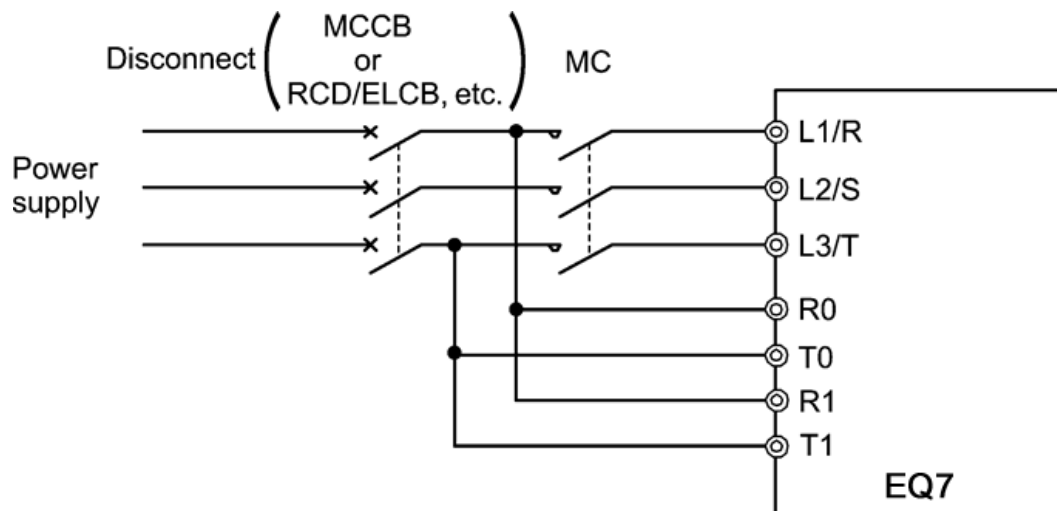

7. When using the inverter as a UL Enclosed Type (UL TYPE1), purchase Type 1 kit (option) and mount it on the inverter as instructed.

Conformity with UL standards and CSA standards (cUL-listed for Canada) (continued)



8. Install UL certified fuses or circuit breaker between the power supply and the inverter, referring to the table below.

Power supply voltage	Nominal applied motor (HP)		Inverter type	CT/VT mode	Class J fuse size (A)	Circuit breaker trip size (A)	Required torque lb-in (N·m)			Wire size AWG (mm ²)									
							Main terminal	Aux. control power supply	Aux. Fan power supply	Main terminal									
	L1/R, L2/S, L3/T									U, V, W			Aux. control power supply	Aux. fan power supply					
	Three-phase	Single-phase					60°C (140°F) Cu wire	75°C (167°F) Cu wire	Remarks	60°C (140°F) Cu wire	75°C (167°F) Cu wire	Remarks							
230 V	0.5	0.25	EQ7-20P5-C	CT/VT	10	5	10.6	-	-	-	-	-	-	-	-	-	-		
	1	0.5	EQ7-2001-C		15	10	(1.2)	-	-	-	-	-	-	-	-	-	-	-	
	2	1	EQ7-2002-C		20	15	-	-	-	-	-	-	-	-	-	-	-	-	-
	3	1.5	EQ7-2003-C		30	20	15.9 (1.8)	-	-	-	-	-	-	-	-	-	-	-	-
	5	3	EQ7-2005-C		40	30	-	-	-	-	-	-	-	-	-	-	-	-	-
	7.5		EQ7-2007-C		60	50	-	-	-	-	-	-	-	-	-	-	-	-	-
	10	5	EQ7-2010-C		CT	75	75	30.9 (3.5)	-	8 (8.4)	-	-	8 (8.4)	-	-	-	-	-	-
	15	7.5	EQ7-2015-C		VT	75	75	30.9 (3.5)	-	6 (13.3)	*2 *3	-	8 (8.4)	*2 *3	-	-	-	-	-
	15	7.5	EQ7-2020-C		CT	100	100	-	-	6 (13.3)	-	-	8 (8.4)	-	-	-	-	-	-
	15	7.5	EQ7-2020-C		VT	100	100	-	-	6 (13.3)	-	-	8 (8.4)	-	-	-	-	-	-
	20	10	EQ7-2025-C		CT	150	125	-	-	4 (21.2)	-	-	6 (13.3)	-	-	-	-	-	-
	25		EQ7-2030-C		VT	175	150	51.3 (5.8)	-	3 (26.7)	-	-	4 (21.2)	-	-	-	-	-	-
	25	10	EQ7-2030-C		CT	175	150	51.3 (5.8)	-	3 (26.7)	-	-	4 (21.2)	-	-	-	-	-	-
	30		EQ7-2040-C		VT	200	175	51.3 (5.8)	-	1 (42.4)	-	-	3 (26.7)	-	-	-	-	-	-
	30	15	EQ7-2040-C		CT	200	175	51.3 (5.8)	-	2 (33.6)	-	-	3 (26.7)	-	-	-	-	-	-
	40	20	EQ7-2050-C		VT	250	200	119.4 (13.5)	-	2 (67.4)	-	-	2 (33.6)	-	-	-	-	-	-
	50	25	EQ7-2050-C		CT	350	250	119.4 (13.5)	-	3 (85)	-	-	3 (26.7)	-	-	-	-	-	-
	50	25	EQ7-2060-C		VT	350	250	119.4 (13.5)	-	3 (85)	-	-	3 (26.7)	-	-	-	-	-	-
	60	30	EQ7-2075-C		CT	400	300	238.9 (27)	-	4 (107.2)	*2 *3	-	4 (107.2)	-	-	-	-	-	-
	75		EQ7-2100-C		VT	450	350	238.9 (27)	-	2/0×2 (67.4×2)	-	-	4 (107.2)	-	-	-	-	-	-
100	40	EQ7-2100-C	CT	500	350	238.9 (27)	-	3/0×2 (85×2)	-	-	3/0×2 (85×2)	-	-	-	-	-	-		
125		EQ7-2125-C	VT	600	400	424.7 (48)	-	4/0×2 (107.2×2)	-	-	4/0×2 (107.2×2)	-	-	-	-	-	-		
150	50	EQ7-2150-C	CT	700	500	424.7 (48)	-	300×2 (152×2)	-	-	300×2 (152×2)	-	-	-	-	-	-		
150	50	EQ7-2150-C	VT	700	500	424.7 (48)	-	300×2 (152×2)	-	-	300×2 (152×2)	-	-	-	-	-	-		

Note 1: Control circuit terminals Tightening torque: 6.1 b-in (0.7 N·m), Recommended wire size: AWG 19 or 18 (0.65 to 0.82 mm²)

*1 No terminal end treatment is required for connection.

*2 Use 75 C (167 F) Cu (Copper) wire only.

*3 The wire size of UL Open Type and Enclosed Type are common. Please contact us if UL Open Type exclusive wire is necessary.

Conformity with UL standards and CSA standards (cUL-listed for Canada) (continued)



Power supply voltage	Nominal applied motor (HP)		Inverter type	CT/VT mode	Class J fuse size (A)	Circuit breaker trip size (A)	Required torque b-in (N·m)		Wire size AWG (mm ²)								
							Main terminal	Aux. control power supply	Aux. Fan power supply	Main terminal			Aux. control power supply	Aux. fan power supply			
	60 C (140 F) Cu wire	75 C (167 F) Cu wire								Remarks	60 C (140 F) Cu wire	75 C (167 F) Cu wire			Remarks		
	Three-phase	Single-phase					L1/R, L2/S, L3/T	U, V, W	Remarks	Remarks	Remarks						
460 V	0.5	0.25	EQ7-40P5-C	CT/VT	3	5	10.6 (1.2)	-	14 (2.1)	14 (2.1)	-	14 (2.1)	14 (2.1)	-	-	-	-
	1	0.5	EQ7-4001-C		6												
	2	1	EQ7-4002-C		10	10	30.9 (3.5)	10.6 (1.2)	-	14 (2.1)	14 (2.1)	-	14 (2.1)	14 (2.1)	-	-	-
	3	1.5	EQ7-4003-C		15	15											
	5	3	EQ7-4005-C		20	20											
	7.5		EQ7-4007-C	30	30												
	10	5	EQ7-4010-C	CT	40	40	10.6 (1.2)	-	14 (2.1)	14 (2.1)	-	14 (2.1)	14 (2.1)	-	-	-	
	15		EQ7-4015-C	VT	60	50											
	20	7.5	EQ7-4020-C	CT	70	60	10.6 (1.2)	-	14 (2.1)	14 (2.1)	-	14 (2.1)	14 (2.1)	-	-	-	
	25		EQ7-4025-C	VT	90	75											
	30	15	EQ7-4030-C	CT	100	100	10.6 (1.2)	-	14 (2.1)	14 (2.1)	-	14 (2.1)	14 (2.1)	-	-	-	
	40		EQ7-4040-C	VT	125	125											
	50	25	EQ7-4050-C	CT	175	175	10.6 (1.2)	-	14 (2.1)	14 (2.1)	-	14 (2.1)	14 (2.1)	-	-	-	
	60		EQ7-4060-C	VT	200	150											
	75	30	EQ7-4075-C	CT	250	200	10.6 (1.2)	-	14 (2.1)	14 (2.1)	-	14 (2.1)	14 (2.1)	-	-	-	
	100		EQ7-4100-C	VT													
	125	50	EQ7-4125-C	CT	350	200	10.6 (1.2)	-	14 (2.1)	14 (2.1)	-	14 (2.1)	14 (2.1)	-	-	-	
	150		EQ7-4150-C	VT													
	200	60	EQ7-4200-C	CT/VT	400	300	10.6 (1.2)	-	14 (2.1)	14 (2.1)	-	14 (2.1)	14 (2.1)	-	-	-	
	250		EQ7-4250-C	VT	500	350											
	300	100	EQ7-4300-C	CT/VT	600	500	424.7 (48)	-	14 (2.1)	14 (2.1)	-	14 (2.1)	14 (2.1)	-	-	-	
	350		EQ7-4350-C	VT	700												
			EQ7-4450-C	CT	700												

Note 1: Control circuit terminals Tightening torque: 6.1 lb-in (0.7 N·m), Recommended wire size: AWG 19 or 18 (0.65 to 0.82 mm²)

*1 No terminal end treatment is required for connection.

*2 Use 75 C (167 F) Cu (Copper) wire only.

*3 The wire size of UL Open Type and Enclosed Type are common. Please contact us if UL Open Type exclusive wire is necessary.

Chapter 1 Drive Model Identification

It is essential to verify the EQ7 drive nameplate and make sure that the EQ7 drive has the correct rating so it can be used in your application with the proper sized AC motor.

Unpack the EQ7 drive and check the following:

- (1) The EQ7 drive and quick start guide (this document) are contained in the package. The EQ7 DRIVE-2100-C / EQ7 DRIVE-4100-C and higher rated types come with a DC reactor (DCR). Be sure to connect the DCR.
- (2) The EQ7 drive has not been damaged during transportation there should be no dents or parts missing.
- (3) The EQ7 drive is the type you ordered. You can check the type and specifications on the main nameplate. (Main and sub nameplates are attached to the EQ7 drive and are located as shown below.)
- (4) Check that the input voltage range meets the input power requirements.
- (5) Ensure that for variable torque applications the motor rated current matches the variable torque FLA or for constant torque applications it matches the constant torque FLA. Verify that the output voltage rating on the EQ7 drive label meets the motor requirements (nameplate).



Model No. EQ7-2020-C			
Serial No. 2XA123A0001 K			
Input		Output Variable Torque	Output Constant Torque
Volts	200-240	20	HP 15
Amps	72.4	200-240	Volts 200-240
Freq(Hz)	50/60	0.1-120	Freq Range(Hz) 0.1-500
Phase(s)	3	59.4	Amps 49
		120%	Overload(1min) 150%
			SCCR 100kA
			
TECO-Westinghouse Motor Company Assembled in China WF			

Figure 1.1 Nameplate

TYPE: Type of inverter

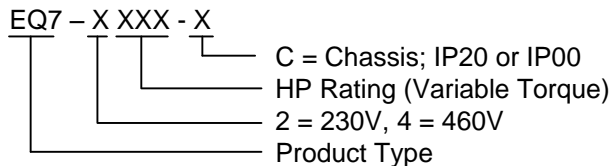

1.1 Drive Models Constant Torque (CT) / Variable Torque (VT) HP Ratings

Voltage	EQ7 DRIVE	Variable Torque HP	Constant Torque HP	Frame / Enclosure
230V	EQ7-20P5-C	0.5	0.5	Plastic
	EQ7-2001-C	1	1	Plastic
	EQ7-2002-C	2	2	Plastic
	EQ7-2003-C	3	3	Plastic
	EQ7-2005-C	5	5	Plastic
	EQ7-2007-C	7.5	7.5	Plastic
	EQ7-2010-C	10	7.5	Plastic
	EQ7-2015-C	15	10	Plastic
	EQ7-2020-C	20	15	Plastic
	EQ7-2025-C	25	20	Plastic
	EQ7-2030-C	30	25	Plastic
	EQ7-2040-C	40	30	Plastic
	EQ7-2050-C	50	40	Sheet Metal
	EQ7-2060-C	60	50	Sheet Metal
	EQ7-2075-C	75	60	Sheet Metal
	EQ7-2100-C	100	75	Sheet Metal
	EQ7-2125-C	125	100	Sheet Metal
EQ7-2150-C	150	125	Sheet Metal	
460V	EQ7-40P5-C	0.5	0.5	Plastic
	EQ7-4001-C	1	1	Plastic
	EQ7-4002-C	2	2	Plastic
	EQ7-4003-C	3	3	Plastic
	EQ7-4005-C	5	5	Plastic
	EQ7-4007-C	7.5	7.5	Plastic
	EQ7-4010-C	10	7.5	Plastic
	EQ7-4015-C	15	10	Plastic
	EQ7-4020-C	20	15	Plastic
	EQ7-4025-C	25	20	Plastic
	EQ7-4030-C	30	25	Plastic
	EQ7-4040-C	40	30	Plastic
	EQ7-4050-C	50	40	Sheet Metal
	EQ7-4060-C	60	50	Sheet Metal
	EQ7-4075-C	75	60	Sheet Metal
	EQ7-4100-C	100	75	Sheet Metal
	EQ7-4125-C	125	100	Sheet Metal
	EQ7-4150-C	150	125/150*	Sheet Metal
	EQ7-4200-C	200	200*	Sheet Metal
	EQ7-4250-C	250	250*	Sheet Metal
	EQ7-4300-C	300	300*	Sheet Metal
	EQ7-4350-C	350	350*	Sheet Metal
	EQ7-4450-C	400/450	350	Sheet Metal
	EQ7-4500-C	500	400/450*	Sheet Metal
	EQ7-4600-C	600	500*	Sheet Metal
EQ7-4700-C	700	600*	Sheet Metal	
EQ7-4800-C	800	700*	Sheet Metal	
EQ7-4900-C	900	800	Sheet Metal	
EQ7-41000-C	1000	900	Sheet Metal	

Table 1.1

This table shows the Variable Torque and Constant Torque ratings for all EQ7 drive models.

* The HP ratings marked with (*) are suitable for constant torque V/F Control. Refer to EQ7 Instruction Manual chapter 11 for constant torque vector control HP ratings.

1.2 Installation and wiring practices

Mounting of the EQ7 drive is extremely important for accessibility as well as for the environment. Various EQ7 drive models are available and the mounting dimensions (footprint) may be different. Install the EQ7 drive in an environment that satisfies the requirements.

TECO-Westinghouse Motor Company strongly recommends installing inverters in a panel for safety reasons, in particular, when installing the ones that have an enclosure rating of IP00.

When installing the EQ7 drive in a place out of the specified environmental requirements, it is necessary to derate the inverter or consider the panel engineering design suitable for the special environment or the panel installation location. For details consult your TECO-Westinghouse Motor Company representative. The special environments listed below require using the specially designed panel or considering the panel installation location.

■ Installation environment

Environments	Possible problems	Sample measures	Applications
Highly concentrated sulfurizing gas or other corrosive gases	Corrosive gases cause parts inside the inverter to corrode, resulting in an inverter malfunction.	Any of the following measures may be necessary. -Mount the inverter in a sealed panel with IP6X or air-purge mechanism. -Place the panel in a room free from influence of the gases.	Paper manufacturing, sewage disposal, sludge treatment, tire manufacturing, gypsum manufacturing, metal processing, and a particular process in textile factories.
A lot of conductive dust or foreign material (e.g., metal powders or shavings, carbon fibers, or carbon dust)	Entry of conductive dust into the inverter causes a short circuit.	Any of the following measures may be necessary. -Mount the inverter in a sealed panel. -Place the panel in a room free from influence of the conductive dust.	Wiredrawing machines, metal processing, extruding machines, printing presses, combustors, and industrial waste treatment.
A lot of fibrous or paper dust	Fibrous or paper dust accumulated on the heat sink lowers the cooling effect. Entry of dust into the inverter causes the electronic circuitry to malfunction.	Any of the following measures may be necessary. -Mount the inverter in a sealed panel that shuts out dust. -Ensure a maintenance space for periodical cleaning of the heat sink in panel engineering design. -Employ external cooling when mounting the inverter in a panel for easy maintenance and perform periodical maintenance.	Textile manufacturing and paper manufacturing.
High humidity or dew condensation	In an environment where a humidifier is used or where the air conditioner is not equipped with a dehumidifier, high humidity or dew condensation results, which causes a short-circuiting or malfunction of electronic circuitry inside the inverter.	- Put a heating module such as a space heater in the panel.	Outdoor installation. Film manufacturing line, pumps and food processing.
Vibration or shock exceeding the specified level	If a large vibration or shock exceeding the specified level is applied to the inverter, for example, due to a carrier running on seam joints of rails or blasting at a construction site, the inverter structure gets damaged.	-Insert shock-absorbing materials between the mounting base of the inverter and the panel for safe mounting.	Installation of an inverter panel on a carrier or self-propelled machine. Ventilating fan at a construction site or a press machine.
Fumigation for export packaging	Halogen compounds such as methyl bromide used in fumigation corrodes some parts inside the inverter.	-When exporting an inverter built in a panel or equipment, pack them in a previously fumigated wooden crate. -When packing an inverter alone for export, use a laminated veneer lumber (LVL).	Exporting.

Table 1.2: Installation environment

■ Storage environment

The storage environment in which the inverter is stored after purchase is different from the operation environment. For details, refer to the EQ7 DRIVE User's Manual, Chapter 2.

■ Wiring precautions

- (1) Route the wiring of the control circuit terminals as far from the wiring of the main circuit as possible. Otherwise electric noise may cause malfunctions.
- (2) Place the control circuit wires inside the inverter to keep them away from the live parts of the main circuit (such as the terminal block of the main circuit).
- (3) If more than one motor is to be connected to a single inverter, the wiring length should be the sum of the length of the wires to the motors.
- (4) Drive output terminals (U, V, W)
 - 1) Connect these terminals to a 3-phase motor in the correct phase sequence. If the direction of motor rotation is incorrect, exchange any two of the U, V, and W phases.
 - 2) Do not connect a power factor correction capacitor or surge suppressor to the inverter output.
 - 3) If the cable from the inverter to the motor is very long, a high-frequency current may be generated by stray capacitance between the cables and result in an overcurrent trip of the inverter, an increase in leakage current, or a reduction in current indication precision.

When a motor is driven by a PWM-type inverter, the motor terminals may be subject to surge voltage generated by inverter element switching. If the motor cable (with 460 V series motors, in particular) is particularly long, surge voltage will deteriorate motor insulation. To prevent this, use the following guidelines:

Inverter 7.5 HP and larger			
Motor Insulation Level	1000 V	1300 V	1600 V
460 VAC Input Voltage	66 ft (20 m)	328 ft (100 m)	1312 ft (400 m)*
230 VAC Input Voltage	1312 ft (400 m)*	1312 ft (400 m)*	1312 ft (400 m)*

Inverter 5 HP and smaller			
Motor Insulation Level	1000 V	1300 V	1600 V
460 VAC Input Voltage	66 ft (20 m)	165 ft (50 m)*	165 ft (50 m)*
230 VAC Input Voltage	328 ft (100 m)*	328 ft (100 m)*	328 ft (100 m)*

* For this case the cable length is determined by secondary effects and not voltage spiking.

- Note**
- When a motor protective thermal O/L relay is inserted between the inverter and the motor, the thermal O/L relay may malfunction (particularly in the 460 V series), even when the cable length is 165 ft (50 m) or less. To correct, insert a filter or reduce the carrier frequency. (Use function code F26 "Motor sound".)
 - For the vector control mode, wiring length is 328 ft (100 m) or less.

- (5) When an output circuit filter is inserted in the secondary circuit or the wiring between the inverter and the motor is long, a voltage loss occurs due to reactance of the filter or wiring so that the insufficient voltage may cause output current oscillation or a lack of motor output torque. To avoid it, select the constant torque load by setting the function code F37 (Load Selection/Auto Torque Boost/Auto Energy Saving Operation 1) to "1" and keep the inverter output voltage at a higher level by configuring H50/H52 (Non-linear V/f Pattern, Frequency) and H51/H53 (Non-linear V/f Pattern, Voltage).

■ Precautions for connection of peripheral equipment

(1) Phase-advancing capacitors for power factor correction

Do not mount a phase-advancing capacitor for power factor correction in the inverter's input (primary) or output (secondary) circuit. Mounting it in the input (primary) circuit takes no effect. To correct the inverter power factor, use an optional DC reactor (DCR). Mounting it in the output (secondary) circuit causes an overcurrent trip, disabling operation.

An overvoltage trip that occurs when the inverter is stopped or running with a light load is assumed to be due to surge current generated by open/close of phase-advancing capacitors in the power system. An optional DC/AC reactor (DCR/ACR) is recommended as a measure to be taken at the inverter side.

Input current to an inverter contains a harmonic component that may affect other motors and phase-advancing capacitors on the same power supply line. If the harmonic component causes any problems, connect an optional DCR/ACR to the inverter. In some cases, it is necessary to insert a reactor in series with the phase-advancing capacitors.

(2) Power supply lines (Application of a DC/AC reactor)

Use an optional DC reactor (DCR) when the capacity of the power supply transformer is 500 kVA or more and is 10 times or more the inverter rated capacity or when there are thyristor-driven loads. If no DCR is used, the percentage-reactance of the power supply decreases, and harmonic components and their peak levels increase. These factors may break rectifiers or capacitors in the converter section of the inverter, or decrease the capacitance of the capacitors.

If the input voltage unbalance rate is 2% to 3%, use an optional AC reactor (ACR).

$$\text{Voltage unbalance(\%)} = \frac{\text{Max voltage (V)} - \text{Min voltage (V)}}{\text{Three-phase average voltage (V)}} \times 67 \text{ (IEC 61800-3)}$$

(3) DC reactor (DCR) for correcting the inverter input power factor (for suppressing harmonics)

To correct the inverter input power factor (to suppress harmonics), use an optional DCR. Using a DCR increases the reactance of inverter's power source so as to decrease harmonic components on the power source lines and correct the power factor of the inverter.

DCR models	Input power factor	Remarks
DCR2/4-□□/□□A/□□B	Approx. 90% to 95%	The last letter identifies the capacitance.
DCR2/4-□□C	Approx. 86% to 90%	Exclusively designed for inverters of 50 HP or above.

 Note For selecting DCR models, refer to Chapter 11 "SPECIFICATIONS."

(4) PWM converter for correcting the inverter input power factor

Using a PWM converter (High power-factor, regenerative PWM converter) corrects the inverter power factor up to nearly 100%. When combining an inverter with a PWM converter, disable the main power down detection by setting the function code H72 to "0." If the main power loss detection is enabled (H72 = 1 by factory default), the inverter interprets the main power as being shut down, ignoring an entry of a run command.

- (5) Molded case circuit breaker (MCCB) or residual-current-operated protective device (RCD)/earth leakage circuit breaker (ELCB)

Install a recommended MCCB or RCD/ELCB (with overcurrent protection) in the primary circuit of the inverter to protect the wiring. Since using an MCCB or RCD/ELCB with a larger capacity than recommended ones breaks the protective coordination of the power supply system, be sure to select recommended ones. Also select ones with short-circuit breaking capacity suitable for the power source impedance.

Molded Case Circuit Breaker (MCCB) and Residual-Current-Operated Protective Device (RCD)/Earth Leakage Circuit Breaker (ELCB)

Power supply voltage	Nominal applied motor (HP)		Inverter type	CT/VT mode	Rated current of MCCB and RCD/ELCB (A)	
	Three-phase	Single-phase			w/ DCR	w/o DCR
230 V	0.5	0.25	EQ7-20P5-C	CT/VT	5	5
	1	0.5	EQ7-2001-C			10
	2	1	EQ7-2002-C		10	15
	3	1.5	EQ7-2003-C			20
	5	3	EQ7-2005-C		20	30
	7.5		EQ7-2007-C	30	50	
	10	5	EQ7-2010-C	CT	40	75
			VT			
	15	7.5	EQ7-2015-C	CT	50	100
			VT			
	20	10	EQ7-2020-C	CT	75	125
			VT			
	25	10	EQ7-2025-C	CT	100	150
			VT			
	30	15	EQ7-2030-C	CT	100	175
			VT			
	40	20	EQ7-2040-C	CT	150	200
			VT			
	50	25	EQ7-2050-C	CT	175	250
			VT			
60	30	EQ7-2060-C	CT	200	300	
		VT				
75	30	EQ7-2075-C	CT	250	350	
		VT				
100	40	EQ7-2100-C	CT	350	--	
		VT				
125	40	EQ7-2125-C	CT	400	--	
		VT				
150	50	EQ7-2150-C	CT	350	--	

Power supply voltage	Nominal applied motor (HP)		Inverter type	CT/VT mode	Rated current of MCCB and RCD/ELCB (A)	
	Three-phase	Single-phase			w/ DCR	w/o DCR
460 V	0.5	0.25	EQ7-40P5-C	CT/VT	5	5
	1	0.5	EQ7-4001-C			10
	2	1	EQ7-4002-C		10	15
	3	1.5	EQ7-4003-C			20
	5	3	EQ7-4005-C		20	30
	7.5		EQ7-4007-C	30	50	
	10	5	EQ7-4010-C	CT	40	75
			VT			
	15	7.5	EQ7-4015-C	CT	50	100
			VT			
	20	10	EQ7-4020-C	CT	75	125
			VT			
	25	10	EQ7-4025-C	CT	100	150
			VT			
	30	15	EQ7-4030-C	CT	150	200
			VT			
	40	20	EQ7-4040-C	CT	200	250
			VT			
	50	25	EQ7-4050-C	CT	250	300
			VT			
60	30	EQ7-4060-C	CT	300	350	
		VT				
75	30	EQ7-4075-C	CT	350	400	
		VT				
100	40	EQ7-4100-C	CT	400	--	
		VT				
100	40	EQ7-4125-C	CT	400	--	

Molded Case Circuit Breaker (MCCB) and Residual-Current-Operated Protective Device (RCD)/Earth



Leakage Circuit Breaker (ELCB)

Power supply voltage	Nominal applied motor (HP)		Inverter type	CT/VT mode	Rated current of MCCB and RCD/ELCB (A)	
	Three-phase	Single-phase			w/ DCR	w/o DCR
460 V	125	50	EQ7-4125-C	VT	200	--
			EQ7-4150-C	CT		
	150	60	EQ7-4200-C	CT	250	
			EQ7-4250-C	CT/VT		
	200	75	EQ7-4300-C	CT	300	
			EQ7-4350-C	CT/VT		
	250	100	EQ7-4450-C	CT	350	
			EQ7-4500-C	CT/VT		
	300	125	EQ7-4600-C	CT	500	
			EQ7-4700-C	CT/VT		
	350	-	EQ7-4800-C	CT	600	
			EQ7-4900-C	VT		
	450	-	EQ7-5000-C	CT	800	
			EQ7-5100-C	VT		
400	-	EQ7-5200-C	CT	800		
		EQ7-5300-C	VT			
450	150	EQ7-5400-C	CT	800		
		EQ7-5500-C	VT			

Power supply voltage	Nominal applied motor (HP)		Inverter type	CT/VT mode	Rated current of MCCB and RCD/ELCB (A)	
	Three-phase	Single-phase			w/ DCR	w/o DCR
460 V	500	150	EQ7-4500-C	VT	800	--
		-	EQ7-4600-C	CT		
	-	150	EQ7-4700-C	CT	800	
			EQ7-4800-C	VT		
	600	200	EQ7-4900-C	CT	1200	
			EQ7-5000-C	VT		
	-	200	EQ7-5100-C	CT	1200	
			EQ7-5200-C	VT		
	700	250	EQ7-5300-C	CT	1200	
			EQ7-5400-C	VT		
	800	300	EQ7-5500-C	CT	1400	
			EQ7-5600-C	VT		
	900	400	EQ7-5700-C	CT	1600	
			EQ7-5800-C	VT		

 WARNING
<p>If no zero-phase current (earth leakage current) detective device such as a ground-fault relay is installed in the upstream power supply line in order to avoid the entire power supply system's shutdown undesirable to factory operation, install a residual-current-operated protective device (RCD)/earth leakage circuit breaker (ELCB) individually to inverters to break the individual inverter power supply lines only.</p> <p>Otherwise, a fire could occur.</p>

(6) Magnetic contactor (MC) in the inverter input (primary) circuit

Avoid frequent ON/OFF operation of the magnetic contactor (MC) in the input circuit; otherwise, the inverter failure may result. If frequent start/stop of the motor is required, use **FWD/REV** terminal signals or the  /  keys on the inverter's keypad.

The frequency of the MC's ON/OFF should not be more than once per 30 minutes. To assure 10-year or longer service life of the inverter, it should not be more than once per hour.



- From the system's safety point of view, it is recommended to employ such a sequence that shuts down the magnetic contactor (MC) in the inverter input circuit with an alarm output signal **ALM** issued on inverter's programmable output terminals. The sequence minimizes the secondary damage even if the inverter breaks.

When the sequence is employed, connecting the MC's primary power line to the inverter's auxiliary control power input makes it possible to monitor the inverter's alarm status on the keypad.

- The breakdown of a braking unit or misconnection of an external braking resistor may trigger that of the inverter's internal parts (e.g., charging resistor). To avoid such a breakdown linkage, introduce an MC and configure a sequence that shuts down the MC if a DC link voltage establishment signal is not issued within three seconds after the MC is switched on.

For the braking transistor built-in type of inverters, assign a transistor error output signal **DBAL** on inverter's programmable output terminals to switch off the MC in the input circuit.

(7) Magnetic contactor (MC) in the inverter output (secondary) circuit

If a magnetic contactor (MC) is inserted in the inverter's output (secondary) circuit for switching the motor to a commercial power or for any other purposes, it should be switched on and off when both the inverter and motor are completely stopped. This prevents the contact point from getting rough due to a switching arc of the MC. The MC should not be equipped with any main circuit surge killer.

Applying a commercial power to the inverter's output circuit breaks the inverter. To avoid it, interlock the MC on the motor's commercial power line with the one in the inverter output circuit so that they are not switched ON at the same time.

(8) Surge absorber/surge killer

Do not install any surge absorber or surge killer in the inverter's output (secondary) lines.

■ Noise reduction

If noise generated from the inverter affects other devices, or that generated from peripheral equipment causes the inverter to malfunction, follow the basic measures outlined below.

(1) If noise generated from the inverter affects the other devices through power wires or grounding wires:

- Isolate the grounding terminals of the inverter from those of the other devices.
- Connect a noise filter to the inverter power wires.
- Isolate the power system of the other devices from that of the inverter with an insulated transformer.
- Decrease the inverter's carrier frequency (F26).

(2) If induction or radio noise generated from the inverter affects other devices:

- Isolate the main circuit wires from the control circuit wires and other device wires.
- Put the main circuit wires through a metal conduit pipe, and connect the pipe to the ground near the inverter.
- Install the inverter into the metal panel and connect the whole panel to the ground.
- Connect a noise filter to the inverter's power wires.
- Decrease the inverter's carrier frequency (F26).

(3) When implementing measures against noise generated from peripheral equipment:

- For inverter's control signal wires, use twisted or shielded-twisted wires. When using shielded-twisted wires, connect the shield of the shielded wires to the common terminals of the control circuit.
- Connect a surge absorber in parallel with magnetic contactor's coils or other solenoids (if any).

■ Leakage current

A high frequency current component generated by insulated gate bipolar transistors (IGBTs) switching on/off inside the inverter becomes leakage current through stray capacitance of inverter input and output wires or a motor. If any of the problems listed below occurs, take an appropriate measure against them.

Problem	Measures
An earth leakage circuit breaker* that is connected to the input (primary) side has tripped. *With overcurrent protection	1) Decrease the carrier frequency. 2) Make the wires between the inverter and motor shorter. 3) Use an earth leakage circuit breaker with lower sensitivity than the one currently used. 4) Use an earth leakage circuit breaker that features measures against the high frequency current component.
An external thermal relay was activated.	1) Decrease the carrier frequency. 2) Increase the current setting of the thermal relay. 3) Use the electronic thermal overload protection built in the inverter, instead of the external thermal relay.

■ Selecting inverter capacity

(1) To drive a general-purpose motor, select an inverter according to the nominal applied motor rating listed in the standard specifications table. When high starting torque is required or quick acceleration or deceleration is required, select an inverter with one rank higher capacity than the standard.

(2) Special motors may have larger rated current than general-purpose ones. In such a case, select an inverter that meets the following condition.

$$\text{Inverter rated current} > \text{Motor rated current}$$

1.3 Precautions in running inverters

Precautions for running inverters to drive motors or motor-driven machinery are described below.

■ Motor temperature

When an inverter is used to run a general-purpose motor, the motor temperature becomes higher than when it is operated with a commercial power supply. In the low-speed range, the motor cooling effect will be weakened, so decrease the output torque of the motor when running the inverter in the low-speed range.

■ Motor noise

When a general-purpose motor is driven by an inverter, the noise level is higher than that when it is driven by a commercial power supply. To reduce noise, raise carrier frequency of the inverter. Operation at 60 Hz or higher can also result in higher noise level.

■ Machine vibration

When an inverter-driven motor is mounted to a machine, resonance may be caused by the natural frequencies of the motor-driven machinery. Driving a 2-pole motor at 60 Hz or higher may cause abnormal vibration. If it happens, do any of the following:

- Consider the use of a rubber coupling or vibration-proof rubber.
- Use the inverter's jump frequency control feature to skip the resonance frequency zone(s).
- Use the vibration suppression related function codes that may be effective. For details, refer to the description of H80 in Chapter 4 "FUNCTION CODES" of the user manual.

1.4 Precautions in using special motors

When using special motors, please read the following section:

■ Explosion-proof motors

When driving an explosion-proof motor with an inverter, use a combination of a motor and an inverter that has been approved in advance.

■ Submersible motors and pumps

These motors have a larger rated current than general-purpose motors. Select an inverter with rated output current that is greater than that of the motor. These motors differ from general-purpose motors in thermal characteristics. Decrease the thermal time constant of the electronic thermal overload protection to match the motor rating.

■ Brake motors

For motors equipped with parallel-connected brakes, their power supply for braking must be supplied from the inverter input (primary) circuit. If the power supply for braking is mistakenly connected to the inverter's output (secondary) circuit, the brake may not work when the inverter output is shut down. Do not use inverters for driving motors equipped with series-connected brakes.

■ Geared motors

If the power transmission mechanism uses an oil-lubricated gearbox or speed changer/reducer, then continuous operation at low speed may cause poor lubrication. Avoid such operation.

■ Synchronous motors

It is necessary to take special measures suitable for this motor type. Contact your TECO-Westinghouse Motor Company representative for details.

■ Single-phase motors

Single-phase motors are not suitable for inverter-driven variable speed operation.

■ High-speed motors

If the reference frequency is set to 120 Hz or higher to drive a high-speed motor, test-run the combination of the inverter and motor beforehand to check it for the safe operation.

■ Precautions for use on single-phase power

An inverter is a device that converts alternating current of the input line to direct current via the ac-to-dc rectifier and then converts it to alternating current via the dc-to-ac switching inverter circuit in order to output the required alternating current. The EQ7 drive is designed to connect to the three-phase power and this manual stipulates the specifications for the use on the three-phase power.

If the inverter designed for connection to three-phase power runs on single-phase power, ripples (voltage fluctuation) on the DC link bus voltage rectified from the input power become larger than those in the inverter running on three-phase power. The DC-voltage ripple affects the inverter output; that is, ripples could be superimposed on the output voltage or current, making control hard.

Accordingly, the inverter may not work in full performance or function correctly. To use the EQ7 drive on single-phase power, therefore, you need to take the following into account.

■ Output current

Select the inverter capacity to keep the output current within the specified level, referring to chapter 11. Output current exceeding the limit extremely increases voltage ripples on the DC link bus, impeding normal operation or resulting in an inverter breakdown.

■ Wiring

When connecting 230 V inverters of 60 HP or above or 460 V ones of 125 HP or above to single-phase power, use L1 and L3 phases since cooling fans and magnetic contactors inside the inverter are supplied with power via L1 and L3. Using L2 does not work cooling fans or magnetic contactors, causing abnormal heat, in the worst case, resulting in an inverter breakdown.

■ Connecting peripheral devices

For the specifications of circuit breakers and fuses to apply, refer to pages 1-6 and 1-7.

■ Configuring function codes

- (1) Cancel the input phase loss protection of the protection/maintenance function with function code H98 (Bit 1 = 0).
This is because the inverter judges single-phase power as a phase loss.
- (2) Limit the drive mode to the VT / CT-V mode (Function code F80 = 0 or 1).
- (3) Do not use "Vector control without speed sensor" or torque control. (Function codes F42 ≠ 5, H18 = 0)
- (4) "V/f control with slip compensation inactive" is recommended (F42 = 0). Any other drive control calculates the motor model using the motor parameters inside the inverter. As ripples on the DC link bus voltage become larger, therefore, calculation causes some errors so that the inverter may not provide the desired performance. Consider this problem before use. In particular, when using "Vector control with speed sensor" (F42 = 6), dancer control (J01 = 3), or brake signals (J68, J69, J70, etc.), assure the operation and safety of those speed sensors.

Chapter 2 Mounting and Wiring the Inverter

2.1 Operating Environment

Install the inverter in an environment that satisfies the requirements listed in Table 2.1.

Table 2.1 Environmental Requirements

Item	Specifications	
Site location	Indoors	
Surrounding/ambient temperature	-10 to +50 C (14 to 122 F) (Note 1)	
Relative humidity	5 to 95% (No condensation)	
Atmosphere	The inverter must not be exposed to dust, direct sunlight, corrosive gases, flammable gases, oil mist, vapor or water drops. Pollution degree 2 (IEC60664-1) (Note 2) The atmosphere can contain a small amount of salt. (0.01 mg/cm ² or less per year) The inverter must not be subjected to sudden changes in temperature that will cause condensation to form.	
Altitude	3300 ft (1000 m) max. (Note 3)	
Atmospheric pressure	86 to 106 kPa	
Vibration	Inverters of 100 HP or below (230 V series) 125 HP or below (460 V series)	Inverters of 125 HP or above (230 V series) 150 HP or above (460 V series)
	0.12 inch (3 mm) (Max. amplitude) 2 to less than 9 Hz 9.8 m/s ² 9 to less than 20 Hz 2 m/s ² 20 to less than 55 Hz 1 m/s ² 55 to less than 200 Hz	0.12 inch (3 mm) (Max. amplitude) 2 to less than 9 Hz 2 m/s ² 9 to less than 55 Hz 1 m/s ² 55 to less than 200 Hz

Table 2.2 Output Current Derating Factor in Relation to Altitude

Altitude	Output current derating factor
3300 ft (1000 m) or lower	1.00
3300 to 4900 ft (1000 to 1500 m)	0.97
4900 to 6600 ft (1500 to 2000 m)	0.95
6600 to 8200 ft (2000 to 2500 m)	0.91
8200 to 9800 ft (2500 to 3000 m)	0.88

(Note 1) When inverters (40 HP or below) are mounted side-by-side without any clearance between them, the surrounding temperature should be within the range from -10 to +40 C (14 to 104 F). This specification also applies to the inverters (40 HP) equipped with a NEMA1 kit.

(Note 2) Do not install the inverter in an environment where it may be exposed to lint, cotton waste or moist dust or dirt which will clog the heat sink of the inverter. If the inverter is to be used in such an environment, install it in a dustproof panel.

(Note 3) If you use the inverter in an altitude above 3300 ft (1000 m), you should apply an output current derating factor as listed in Table 2.2.

2.2 Installing the Inverter

(1) Mounting base

Install the inverter on a base made of metal or other non-flammable material.

⚠ WARNING
Install the inverter on a base made of metal or other non-flammable material. Otherwise, a fire could occur.

(2) Clearances

Ensure that the minimum clearances indicated in Figure 2.1 and Table 2.3 are maintained at all times. When mounting the inverter in the panel of your system, take extra care with ventilation inside the panel as the surrounding temperature easily rises. Do not mount the inverter in a small panel with poor ventilation.

■ When mounting two or more inverters

When mounting two or more inverters in the same unit or panel, install them side by side. When one must be mounted above the other, be sure to separate them with a partition plate, or the like, so that any heat radiating from an inverter will not affect the one/s above.

As long as the surrounding temperature is 40°C (104°F) or lower, inverters of 40 HP or below can be mounted side by side without any clearance between them.

Table 2.3 Clearances inch (mm)

Inverter capacity	A	B	C
0.5 to 2 HP	2.0 (50)	3.9 (100)	0
3 to 40 HP	0.39 (10)		3.9 (100)
50 to 450 HP	2.0 (50)	5.9 (150)	3.9 (100)
500 to 1000 HP			5.9 (150)

C: Space required in front of the inverter unit

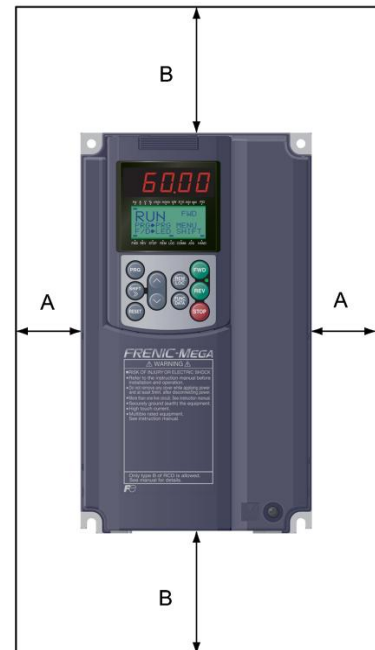

Figure 2.1 Mounting Direction and Required Clearances

■ **When employing external cooling**

In external cooling, the heat sink, which dissipates about 70% of the total heat (total loss) generated into air, is situated outside the equipment or the panel. The external cooling, therefore, significantly reduces heat radiating inside the equipment or panel. To employ external cooling for inverters (except DCR built-in type) of 40 HP or below, use the mounting adapter for external cooling (option); for those of 50 HP or above, simply change the positions of the mounting bases.

Note The DCR built-in type of 40 HP or below cannot employ external cooling.

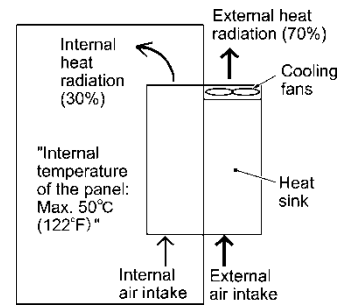

Figure 2.2 External Cooling

CAUTION
Prevent lint, paper fibers, sawdust, dust, metallic chips, or other foreign materials from getting into the inverter or from accumulating on the heat sink.
Otherwise, a fire or accident could occur.

To utilize external cooling for inverters of 50 HP or above, change the positions of the top and bottom mounting bases from the edge to the center of the inverter as shown in Figure 2.3.

Screws differ in size and count for each inverter. Refer to the table below.

Table 2.4 Screw Size, Count and Tightening Torque

Inverter type	Base fixing screw (Screw size and q'ty)	Case fixing screw (Screw size and q'ty)	Tightening torque lb-in (N.m)
EQ7-2050-C /EQ7-2060-C EQ7-4050-C EQ7-4100-C	M6 × 20 5 pcs for upper side, 3 pcs for lower side	M6 × 20 2 pcs for upper side	51.3 (5.8)
EQ7-2075-C / EQ7-4100-C EQ7-4125-C	M6 × 20 3 pcs each for upper and lower sides	M6 × 12 3 pcs for upper side	51.3 (5.8)
EQ7-2125-C EQ7-4150-C / EQ7-4200-C	M5 × 12 7 pcs each for upper and lower sides	M5 × 12 7 pcs for upper side	31.0 (3.5)
EQ7-4250-C / EQ7-4300-C	M5 × 16 7 pcs each for upper and lower sides	M5 × 16 7 pcs for upper side	31.0 (3.5)
EQ7-2150-C EQ7-4350-C / EQ7-4450-C	M5 × 16 8 pcs each for upper and lower sides	M5 × 16 8 pcs for upper side	31.0 (3.5)
EQ7-4500-C / EQ7-4600-C EQ7-4700-C / EQ7-4800-C	M5 × 16 2 pcs each for upper and lower sides M6 × 20 6 pcs each for upper and lower sides	M5 × 16 2 pcs each for upper and lower sides M6 × 20 6 pcs each for upper and lower sides	31.0 (3.5) 51.3 (5.8)
EQ7-4900-C / EQ7-41000-C	M8 × 20 8 pcs each for upper and lower sides	M8 × 20 8 pcs each for upper and lower sides	119 (13.5)

- 1) Remove all base fixing screws and case fixing screws from the top of the inverter.
- 2) Move the top mounting base to the center of the inverter and secure it to the case fixing screw holes with the base fixing screws. (After changing the position of the top mounting base, some screws may be left unused.)
- 3) Remove the base fixing screws from the bottom of the inverter, move the bottom mounting base to the center of the inverter, and secure it with the base fixing screws, just as in step 2). (Inverters of 450 HP or below have no case fixing screws on the bottom.)

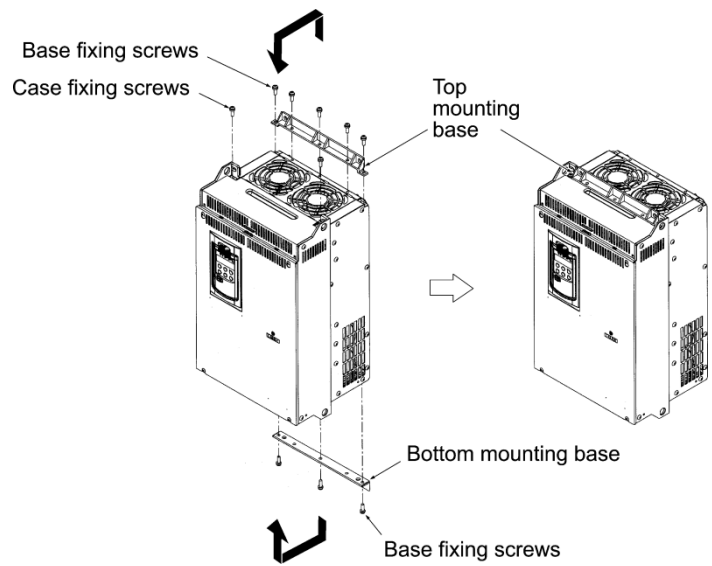

Figure 2.3 Changing the Positions of the Top and Bottom Mounting Bases

⚠ CAUTION

When changing the positions of the top and bottom mounting bases, use only the specified screws.
Otherwise, a fire or accident could occur.

(3) Mounting notes

The EQ7-2007-C / EQ7-4007-C through EQ7-2040-C / EQ7-4040-C should be mounted with four screws or bolts using screw holes A or B shown below. Note that, at each of the top and bottom of the inverter, the two screws or bolts should be located in a bilaterally symmetrical position.

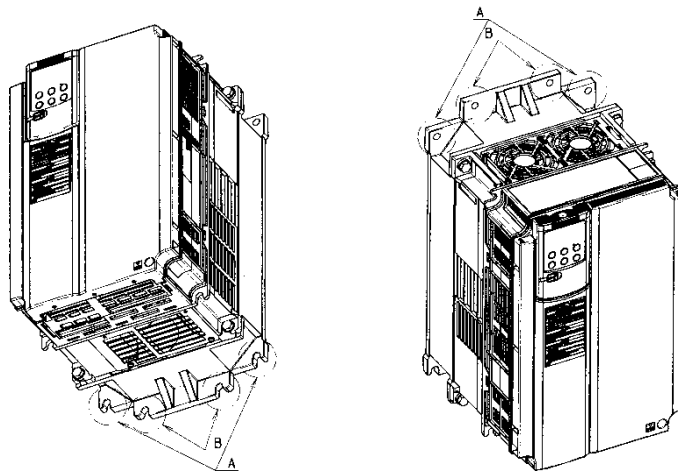

2.3 Wiring

Follow the procedure below. (In the following description, the inverter has already been installed.)

2.3.1 Removing and mounting the front cover and the wiring guide

(1) For inverters of 40 HP or below

- ① First loosen the front cover fixing screw, slide the cover downward holding both sides, tilt it forward, and then pull it upward, as shown below.
- ② While pressing the wiring guide upward, pull it out and forward.
- ③ After carrying out wiring (see Sections 2.3.2 through 2.3.6), put the wiring guide and the front cover back into place in the reverse order of removal.

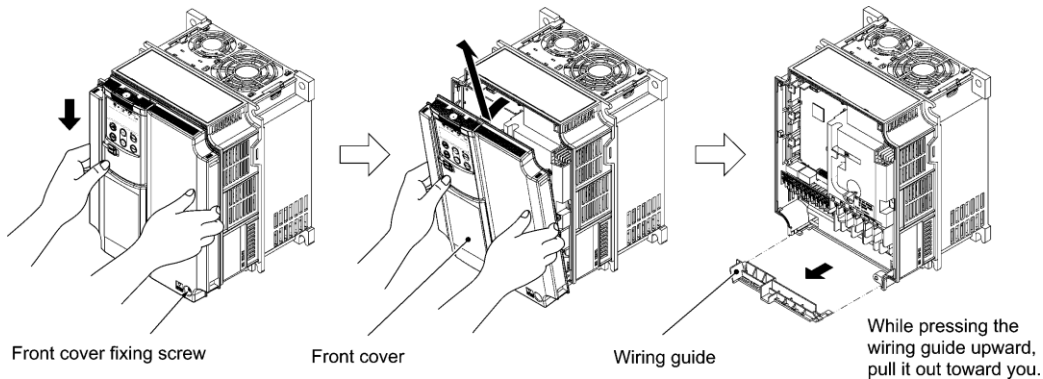

Figure 2.4 Removing the Front Cover and the Wiring Guide (e.g EQ7-4020-C)

(2) For inverters of 50 to 1000 HP

- ① Loosen the four front cover fixing screws, hold the cover with both hands, slide it upward slightly, and pull it forward, as shown below.
- ② After carrying out wiring (see Sections 2.3.2 through 2.3.6), align the screw holes provided in the front cover with the screws on the inverter case, and then put the front cover back into place in the reverse order of removal.

Tip To expose the control printed circuit board (control PCB), open the keypad enclosure.

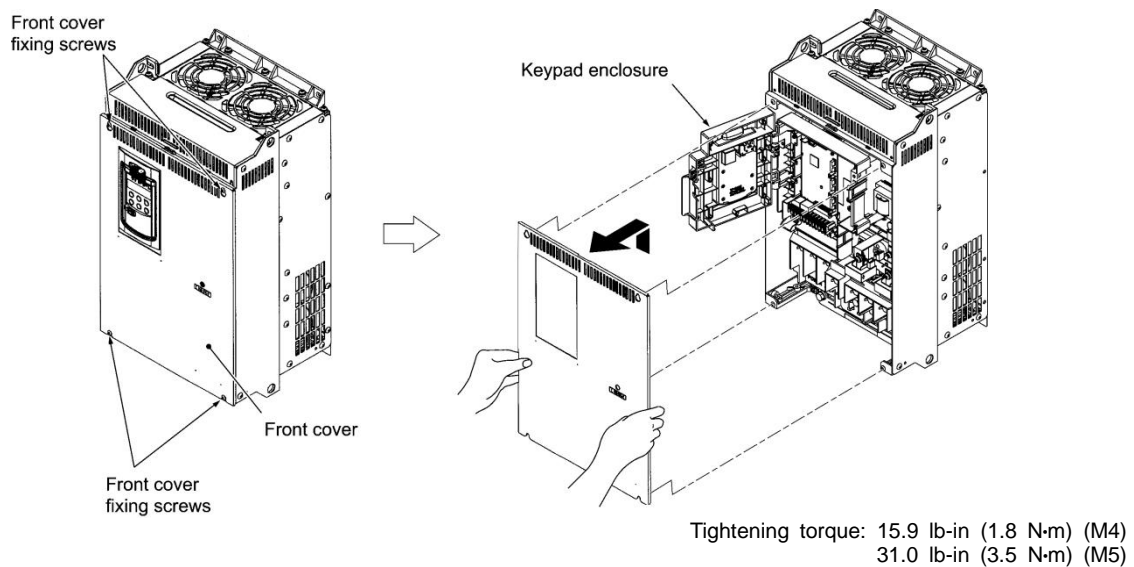

Figure 2.5 Removing the Front Cover (e.g. EQ7-4050-C)

2.3.2 Screw specifications and recommended wire sizes

(1) Arrangement of main circuit terminals

The tables and figures given below show the screw specifications and wire sizes. Note that the terminal arrangements differ depending on the inverter types. In each of the figures, two grounding terminals (⊕G) are not exclusive to the power supply wiring (primary circuit) or motor wiring (secondary circuit).

Use crimp terminals covered with an insulation sheath or with an insulation tube.

The recommended wires for main circuit terminals are selected according to the sizes conforming to UL508C.

Table 2.5 Screw Specifications

Inverter type		Refer to:	Screw specifications								
Three-phase 230 V	Three-phase 460 V		Main circuit terminals		Grounding terminals		Auxiliary control power input terminals [R0, T0]		Auxiliary fan power input terminals [R1, T1]		
			Screw size	Tightening torque lb-in (N·m)	Screw size	Tightening torque lb-in (N·m)	Screw size	Tightening torque lb-in (N·m)	Screw size	Tightening torque lb-in (N·m)	
EQ7-20P5-C	EQ7-40P5-C	Figure A	M3.5	10.6 (1.2)	M3.5	10.6 (1.2)	--	--			
EQ7-2001-C	EQ7-4001-C										
EQ7-2002-C	EQ7-4002-C	Figure B	M4	15.9 (1.8)	M4	15.9 (1.8)					
EQ7-2003-C	EQ7-4003-C										
EQ7-2005-C	EQ7-4005-C	Figure C	M5	31.0 (3.5)	M5	31.0 (3.5)			--	--	
EQ7-2007-C	EQ7-4007-C										
EQ7-2010-C	EQ7-4010-C										
EQ7-2015-C	EQ7-4015-C	Figure D	M6	51.3 (5.8)	M6	51.3 (5.8)					
EQ7-2020-C	EQ7-4010-C										
EQ7-2025-C	EQ7-4025-C	Figure E	M8	119 (13.5)	M8	119 (13.5)	M3.5	10.6 (1.2)			
EQ7-2030-C	EQ7-4030-C										
EQ7-2040-C	EQ7-4040-C	Figure F	M10	239 (27)							
EQ7-2050-C	EQ7-4050-C										
EQ7-2060-C	EQ7-4060-C										
EQ7-2075-C	EQ7-4075-C										
EQ7-2100-C	EQ7-4100-C	Figure G									
--	EQ7-4150-C										
--	EQ7-4200-C	Figure M									
EQ7-2125-C	--										
--	EQ7-4250-C										
--	EQ7-4300-C	Figure H									
--	EQ7-4350-C										
EQ7-2150-C	EQ7-4450-C	Figure I	M12	425 (48)	M10	239 (27)				M3.5	10.6 (1.2)
--	EQ7-4500-C										
--	EQ7-4600-C	Figure J									
--	EQ7-4700-C										
--	EQ7-4800-C	Figure K									
--	EQ7-4900-C										
--	EQ7-41000-C	Figure L									

⚠ WARNING ⚠

When the inverter power is ON, a high voltage is applied to the following terminals.

Main circuit terminals: L1/R, L2/S, L3/T, P1, P(+), N(-), DB, U, V, W, R0, T0, R1, T1, AUX-contact (30A, 30B, 30C, Y5A, Y5C)

Insulation level

Main circuit - Enclosure : Basic insulation (Overvoltage category III, Pollution degree 2)

Main circuit - Control circuit : Reinforced insulation (Overvoltage category III, Pollution degree 2)

Relay output - Control circuit : Reinforced insulation (Overvoltage category II, Pollution degree 2)

An electric shock may occur.

Figure A

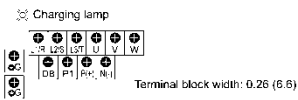

Figure B

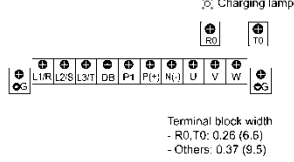

Figure C

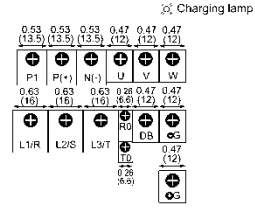

Figure D

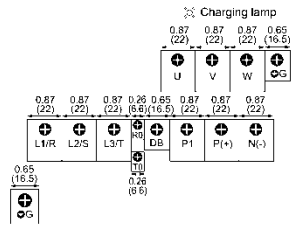

Figure E

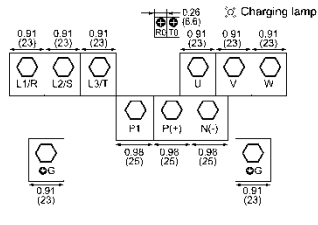

Figure F / Figure G

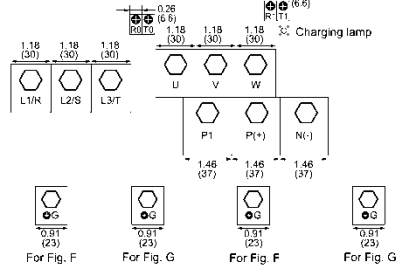

Figure H / Figure I

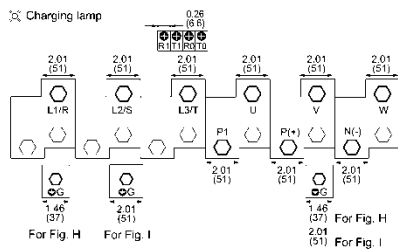

Figure J

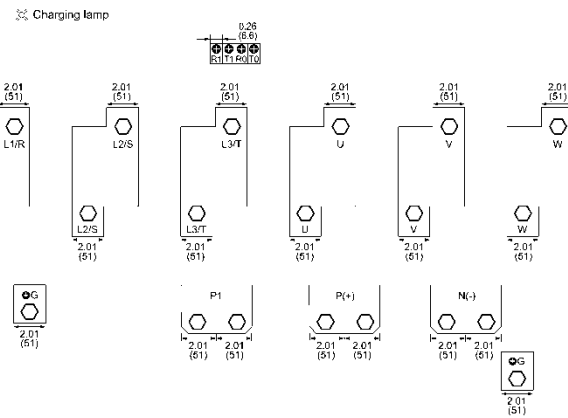

Figure K

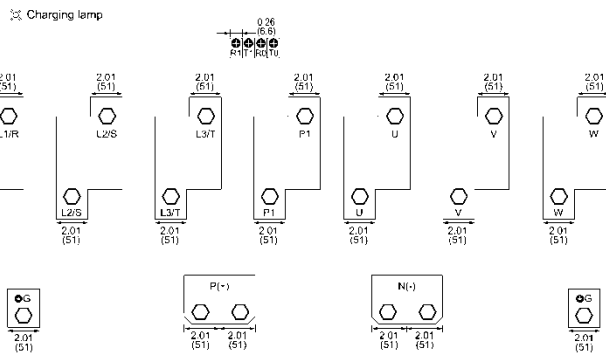

Figure M

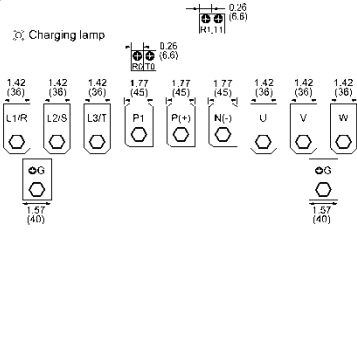

Figure L

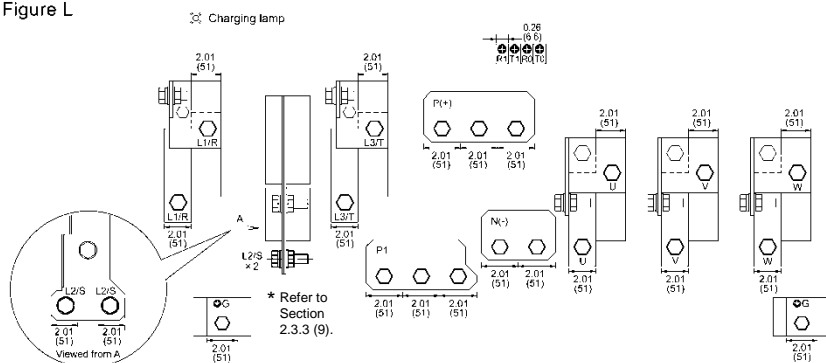

Table 2.6 Recommended Wire Sizes

Power supply voltage	Inverter type			Recommended wire size AWG (mm ²)				
	Variable Torque mode	Constant Torque mode	CT-Vector mode	L1/R, L2/S, L3/T	Grounding [EG]	U, V, W	DCR [P1, P(+)]	Braking resistor [P(+), DB]
Single-phase/ Three-phase 230V	EQ7-20P5-C	EQ7-20P5-C	EQ7-20P5-C	14 (2.1)	14 (2.1)	14 (2.1)	14 (2.1)	10 (5.3)
	EQ7-2001-C	EQ7-2001-C	EQ7-2001-C		12 (3.3)			
	EQ7-2002-C	EQ7-2002-C	EQ7-2002-C		10 (5.3)			
	EQ7-2003-C	EQ7-2003-C	EQ7-2003-C					
	EQ7-2005-C	EQ7-2005-C	EQ7-2005-C	10 (5.3)				
	EQ7-2007-C	EQ7-2007-C	EQ7-2007-C	8 (8.4)	8 (8.4)	8 (8.4)		
	--	--	EQ7-2010-C					
	EQ7-2010-C	EQ7-2010-C	--	6 (13.3)	8 (8.4)	4 (21.2)		
	--	--	EQ7-2015-C					
	EQ7-2015-C	EQ7-2015-C	EQ7-2020-C	4 (21.2)	6 (13.3)	6 (13.3)	3 (26.7)	
	EQ7-2020-C	EQ7-2020-C	EQ7-2025-C	3 (26.7)		4 (21.2)	2 (33.6)	
	EQ7-2025-C	EQ7-2025-C	EQ7-2030-C	2 (33.6)		3 (26.7)	1 (42.4)	
	EQ7-2030-C	EQ7-2030-C	EQ7-2040-C	--	4 (21.2)	2 (33.6)	2/0 (67.4)	
	EQ7-2040-C	EQ7-2040-C	--	1 (42.4)				
	--	EQ7-2050-C	--	3/0 (85)	3 (26.7)	1/0 (53.5)	4/0 (107.2)	
	EQ7-2050-C	--	EQ7-2060-C	4/0 (107.2)		4/0 (107.2)	250 (127)	
	EQ7-2060-C	EQ7-2060-C	EQ7-2075-C	2/0 (67.4) × 2	2 (33.6)	3/0 (85) × 2	350 (177)	
	EQ7-2075-C	EQ7-2075-C	EQ7-2100-C	3/0 (85) × 2				
	EQ7-2100-C	EQ7-2100-C	EQ7-2125-C	4/0 (107.2) × 2	1 (42.4)	4/0 (107.2) × 2	500 (253)	
	EQ7-2125-C	EQ7-2125-C	EQ7-2150-C	300 (152) × 2	1/0 (53.5)	300 (152) × 2	4/0 (107.2) × 2	
EQ7-2150-C	EQ7-2150-C	--						
Single-phase/ Three-phase 460V	EQ7-40P5-C	EQ7-40P5-C	EQ7-40P5-C	14 (2.1)	14 (2.1)	14 (2.1)	14 (2.1)	10 (5.3)
	EQ7-4001-C	EQ7-4001-C	EQ7-4001-C		12 (3.3)			
	EQ7-4002-C	EQ7-4002-C	EQ7-4002-C		12 (3.3)			
	EQ7-4003-C	EQ7-4003-C	EQ7-4003-C					
	EQ7-4005-C	EQ7-4005-C	EQ7-4005-C	12 (3.3)	10 (5.3)	12 (3.3)		
	EQ7-4007-C	EQ7-4007-C	EQ7-4007-C	10 (5.3)		10 (5.3)		
	--	--	EQ7-4010-C	8 (8.4)	8 (8.4)	8 (8.4)		
	EQ7-4010-C	EQ7-4010-C	EQ7-4015-C					
	EQ7-4015-C	EQ7-4015-C	--	6 (13.3)	8 (8.4)	6 (13.3)		
	--	--	EQ7-4020-C					
	EQ7-4020-C	EQ7-4020-C	--	4 (21.2)	6 (13.3)	4 (21.2)		
	--	--	EQ7-4025-C					
	EQ7-4025-C	EQ7-4025-C	EQ7-4030-C	3 (26.7)	6 (13.3)	2 (33.6)	2 (33.6)	
	EQ7-4030-C	EQ7-4030-C	EQ7-4040-C	2 (33.6)				
	EQ7-4040-C	EQ7-4040-C	--	1/0 (53.5)	4 (21.2)	1/0 (53.5)	1/0 (53.5)	
	--	--	EQ7-4050-C					
	EQ7-4050-C	EQ7-4050-C	EQ7-4060-C	2/0 (67.4)	4 (21.2)	4/0 (107.2)	3/0 (85)	
	EQ7-4060-C	EQ7-4060-C	EQ7-4075-C	1/0 (53.5)				
	EQ7-4075-C	EQ7-4075-C	EQ7-4100-C	1/0 (53.5)	3 (26.7)	1/0 (53.5)	4/0 (107.2)	
	EQ7-4100-C	EQ7-4100-C	--	2/0 (67.4)		2 (33.6)	250 (127)	
	EQ7-4125-C	EQ7-4125-C	EQ7-4150-C	3/0 (85) × 2	2 (33.6)	3/0 (85) × 2	350 (177)	
	EQ7-4150-C	EQ7-4150-C	EQ7-4200-C	4/0 (107.2) × 2		1 (42.4)	250 (127) × 2	600 (304)
	EQ7-4200-C	EQ7-4200-C	EQ7-4250-C	250 (127) × 2	1/0 (53.5)	300 (152) × 2	4/0 (107.2) × 2	
	EQ7-4250-C	EQ7-4250-C	EQ7-4300-C	300 (152) × 2		350 (177) × 2	250 (127) × 2	
	EQ7-4300-C	EQ7-4300-C	EQ7-4350-C	400 (203) × 2	2/0 (67.4)	400 (203) × 2	300 (152) × 2	
	EQ7-4350-C	EQ7-4350-C	EQ7-4450-C	250 (127) × 2		300 (152) × 2	350 (177) × 2	
	--	EQ7-4450-C	--	300 (152) × 2	3/0 (85)	400 (203) × 2	400 (203) × 2	
	EQ7-4450-C	--	--	400 (203) × 2		500 (253) × 2	500 (253) × 2	
	--	--	EQ7-4500-C	250 (127) × 2	4/0 (107.2)	600 (304) × 2	300 (152) × 3	
	--	EQ7-4500-C	EQ7-4600-C	300 (152) × 2		400 (203) × 3	400 (203) × 3	
	EQ7-4500-C	EQ7-4600-C	EQ7-4700-C	400 (203) × 2	3/0 (85)	400 (203) × 2	400 (203) × 2	
	EQ7-4600-C	EQ7-4700-C	EQ7-4800-C	500 (253) × 2		500 (253) × 2	500 (253) × 2	
	EQ7-4700-C	EQ7-4800-C	--	600 (304) × 2	4/0 (107.2)	600 (304) × 2	300 (152) × 3	
EQ7-4800-C	--	EQ7-4900-C	350 (177) × 3	400 (203) × 3		400 (203) × 3		
EQ7-4900-C	--	EQ7-41000-C	500 (253) × 3	250 (127)	600 (304) × 3	600 (304) × 3		
EQ7-41000-C	--	--	600 (304) × 3	350 (177)	500 (253) × 4	400 (203) × 4		

Note: The wire sizes above are specified for 75 C (167 F) copper (Cu) wire.

Terminals common to all inverters	Recommended wire size AWG (mm ²)	Remarks
Auxiliary control power input terminals [R0] and [T0]	14 (2.1)	2 HP or above
Auxiliary fan power input terminals [R1] and [T1]		230 V series with 60 HP or above 460 V series with 125 HP or above

(2) Arrangement of control circuit terminals (common to all inverter types)

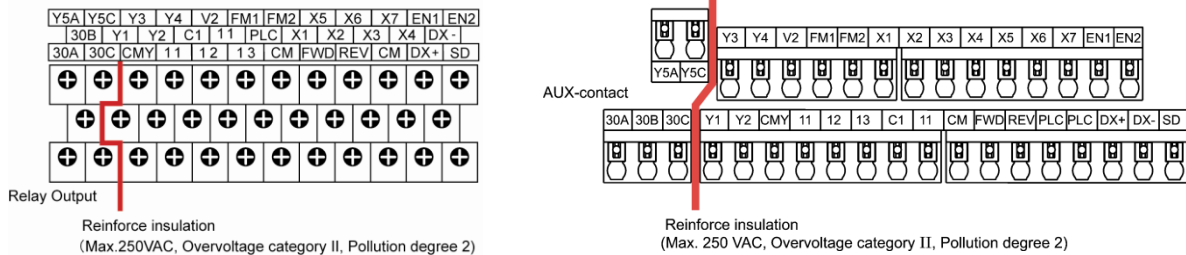

Terminal type	Screw size: M3 (0.7 N·m)	Spring (screwless)
Recommended wiring size (mm ²)*	0.75	0.65 to 0.82 (AWG 19 or 18)

* Using wires exceeding the recommended sizes may lift the front cover depending upon the number of wires used, impeding keypad's normal operation.

2.3.3 Wiring precautions

Follow the rules below when performing wiring for the inverter.

- (1) Make sure that the source voltage is within the rated voltage range specified on the nameplate.
- (2) Be sure to connect the three-phase power wires to the main circuit power input terminals L1/R, L2/S and L3/T of the inverter. If the power wires are connected to other terminals, the inverter will be damaged when the power is turned ON.
- (3) Always connect the grounding terminal to prevent electric shock, fire or other disasters and to reduce electric noise.
- (4) Use crimp terminals covered with insulated sleeves for the main circuit terminal wiring to ensure a reliable connection.
- (5) Keep the power supply wiring (primary circuit) and motor wiring (secondary circuit) of the main circuit, and control circuit wiring as far away as possible from each other.
- (6) After removing a screw from the main circuit terminal block, be sure to restore the screw even if no wire is connected.
- (7) Use the wiring guide to separate wiring. For inverters of 5 HP or below, the wiring guide separates the main circuit wires and the control circuit wires. For those of 7.5 to 40 HP, it separates the upper and lower main circuit wires, and control circuit wires. Be careful about the wiring order.

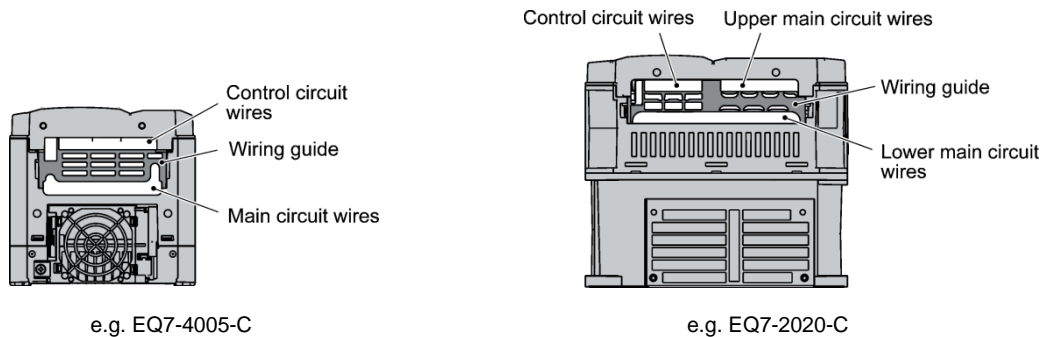

■ Preparing for the wiring guide

Inverters of 20 to 40 HP (three-phase, 230 V series) are sometimes lacking in wiring space for main circuit wires depending upon the wire materials used. To assure a sufficient wiring space, remove the clip-off sections (see below) as required with a nipper. Note that the enclosure rating of IP20 may not be ensured when the wiring guide itself is removed to secure a space for thick main circuit wiring.

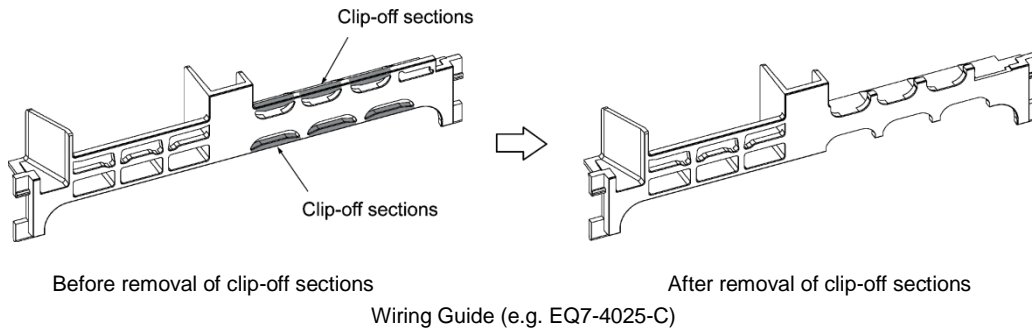

- (8) In some types of inverters, the wires from the main circuit terminal block cannot be routed straight into the terminal. Route such wires as shown below so that the front cover can be reinstalled.

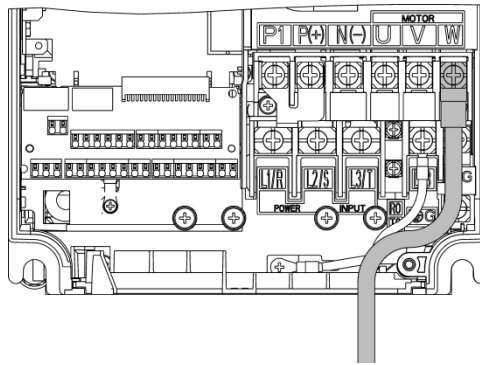

- (9) For inverters of 900 and 1000 HP, two L2/S input terminals are arranged vertically to the terminal block. When connecting wires to these terminals, use the bolts, washers and nuts that come with the inverter, as shown below.

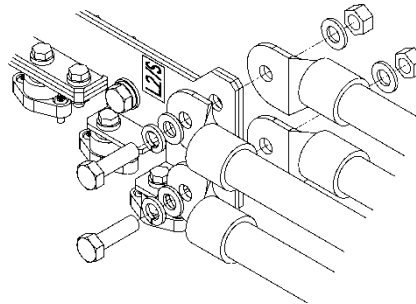

WARNING

- When wiring the inverter to the power source, insert a recommended molded case circuit breaker (MCCB) or residual-current-operated protective device (RCD)/earth leakage circuit breaker (ELCB) (with overcurrent protection) in the path of each pair of power lines to inverters. Use the recommended devices within the recommended current capacity.
- Be sure to use wires in the specified size.
- Tighten terminals with specified torque.

Otherwise, a fire could occur.

- When there is more than one combination of an inverter and motor, do not use a multiconductor cable for the purpose of running the leads together.
- Do not connect a surge killer to the inverter's output (secondary) circuit.

Doing so could cause a fire.

- Ground the inverter in compliance with the national or local electric code.
- Be sure to ground the inverter's grounding terminals .

Otherwise, an electric shock or fire could occur.

- Qualified electricians should carry out wiring.
- Be sure to perform wiring after turning the power OFF.

Otherwise, electric shock could occur.

- Be sure to perform wiring after installing the inverter unit.

Otherwise, electric shock or injuries could occur.

- Ensure that the number of input phases and the rated voltage of the product match the number of phases and the voltage of the AC power supply to which the product is to be connected.

Otherwise, a fire or an accident could occur.

- Do not connect the power source wires to inverter output terminals (U, V, and W).

Doing so could cause fire or an accident.

2.3.4 Wiring of main circuit terminals and grounding terminals

This section shows connection diagrams with the Enable input function used.

SINK mode input by factory default

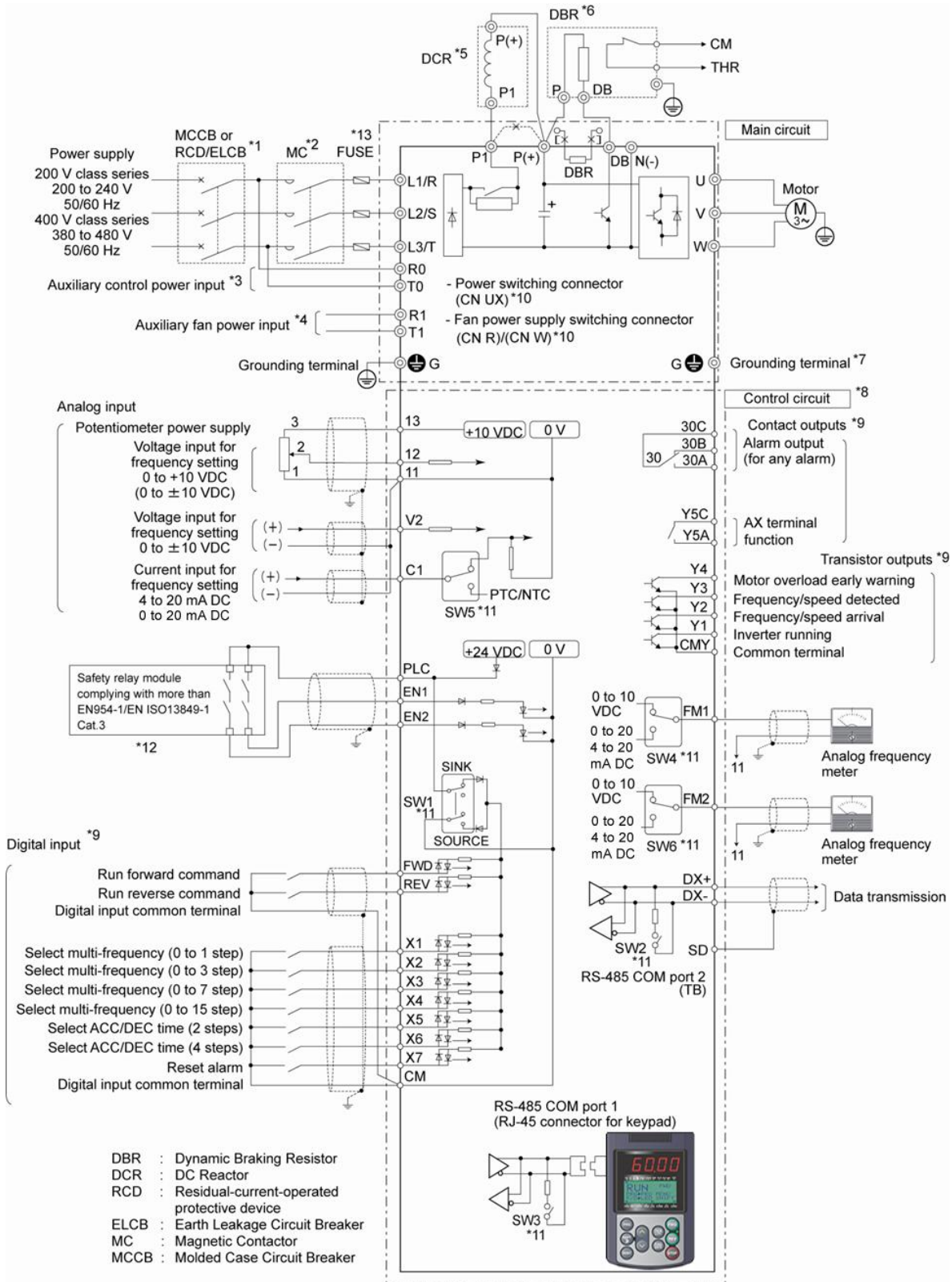

- *1 Install a recommended molded case circuit breaker (MCCB) or residual-current-operated protective device (RCD)/earth leakage circuit breaker (ELCB) (with overcurrent protection function) in the primary circuit of the inverter to protect wiring. Ensure that the circuit breaker capacity is equivalent to or lower than the recommended capacity.
- *2 Install a magnetic contactor (MC) for each inverter to separate the inverter from the power supply, apart from the MCCB or RCD/ELCB, when necessary.
Connect a surge absorber in parallel when installing a coil such as the MC or solenoid near the inverter.
- *3 The R0 and T0 terminals are provided for inverters with a capacity of 2 HP or above.
To retain an alarm output signal **ALM** issued on inverter's programmable output terminals by the protective function or to keep the keypad alive even if the main power has shut down, connect these terminals to the power supply lines. Without power supply to these terminals, the inverter can run.
- *4 Normally no need to be connected. Use these terminals when the inverter is equipped with a high power-factor, regenerative PWM converter (RHC series).
- *5 When connecting an optional DC reactor (DCR), remove the jumper bar from the terminals P1 and P(+).
EQ7-2100-C/EQ7-4100-C and larger HP models require a DCR (packed with the EQ7) to be connected.
Use a DCR when the capacity of the power supply transformer exceeds 500 kVA and is 10 times or more the inverter rated capacity, or when there are thyristor-driven loads in the same power supply line.
- *6 EQ7-2015-C/EQ7-4015-C and smaller have a built-in braking resistor (DBR) between the terminals P(+) and DB.
When connecting an external braking resistor (DBR), be sure to disconnect the built-in one.
- *7 A grounding terminal for a motor. Use this terminal if needed.
- *8 For control signal wires, use twisted or shielded-twisted wires. When using shielded-twisted wires, connect the shield of them to the common terminals of the control circuit. To prevent malfunction due to noise, keep the control circuit wiring away from the main circuit wiring as far as possible (recommended: 10 cm/3.9 inches or more). Never install them in the same wire duct. When crossing the control circuit wiring with the main circuit wiring, set them at right angles.
- *9 The connection diagram shows factory default functions assigned to digital input terminals [X1] to [X7], [FWD] and [REV], transistor output terminals [Y1] to [Y4], and relay contact output terminals [Y5A/C] and [30A/B/C].
- *10 Switching connectors in the main circuits. For details, refer to "Instruction manual section 2.3.4 ⑥ Switching connectors" later in this section.
- *11 Slide switches on the control printed circuit board (control PCB). Use these switches to customize the inverter operations. For details, refer to Section 2.3.6 "Setting up the slide switches."
- *12 When the Enable input function is not to be used, keep terminals [EN1]-[PLC] and terminals [EN2]-[PLC] short-circuited using jumper wires. For opening and closing the hardware circuit between terminals [EN1] and [PLC] and between [EN2] and [PLC], use safety components such as safety relays and safety switches that comply with EN954-1 or EN ISO13849-1 Category 3 or higher.
- *13 To bring the inverter into compliance with the European Standard, Low Voltage Directive EN61800-5-1, be sure to insert the specified fuse in the primary circuit of the inverter.

① Primary grounding terminal (⚡G) for inverter enclosure

Two grounding terminals (⚡G) are not exclusive to the power supply wiring (primary circuit) or motor wiring (secondary circuit). Be sure to ground either of the two grounding terminals for safety and noise reduction. The inverter is designed for use with safety grounding to avoid electric shock, fire and other disasters.

The grounding terminal for inverter enclosure should be grounded as follows:

- 1) Ground the inverter in compliance with the national or local electric code.
- 2) Use a thick grounding wire with a large surface area and keep the wiring length as short as possible.

② Inverter output terminals U, V, and W and secondary grounding terminals (⚡G) for motor

Inverter's output terminals should be connected as follows:

- 1) Connect the three wires of the 3-phase motor to terminals U, V, and W, aligning the phases each other.
- 2) Connect the secondary grounding wire to the grounding terminal (⚡G).

Note When there is more than one combination of an inverter and motor, do not use a multi-conductor cable for the purpose of running the leads together.

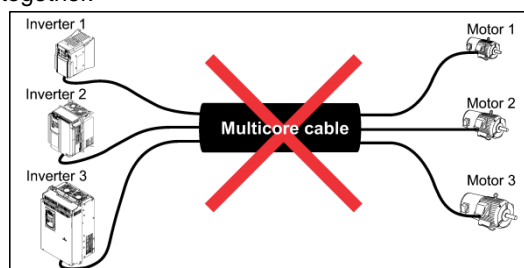

③ DC reactor terminals P1 and P (+)

Connect a DC reactor (DCR) to these terminals for power factor correction.

- 1) Remove the jumper bar from terminals P1 and P(+).
- 2) Connect an optional DCR to those terminals.

- Note**
- The wiring length should be 33 ft (10 m) or below.
 - Do not remove the jumper bar when a DCR is not used.
 - The EQ7-2100-C / EQ7-4100-C and higher types come with a DCR. Be sure to connect the DCR.
 - If a PWM converter is connected to the inverter, no DCR is required.

⚠ WARNING
Be sure to connect an optional DC reactor (DCR) when the capacity of the power supply transformer exceeds 500 kVA and is 10 times or more the inverter rated capacity. Otherwise, a fire could occur.

④ DC braking resistor terminals P(+) and DB (for inverters of 40 HP or below)

Capacity (HP)	Braking transistor	Built-in DC braking resistor (DBR)	Optional devices	Option mounting steps required
0.5 to 15	Built-in	Built-in	External DC braking resistor (with a larger capacity)	1), 2), 3)
20 to 40	Built-in	None	External DC braking resistor	2), 3)

For inverters of 15 HP or below, if the capacity of the built-in DC braking resistor (DBR) is insufficient since the inverter undergoes frequent start/stop or heavy inertial load, mount an optional external DC braking resistor (DBR) with a larger capacity to increase the braking capability, using the following steps. Before mounting the external DBR, remove the built-in DBR.

- 1) For inverters of 0.5 to 5 HP, disconnect the wiring of the built-in DBR from terminals P(+) and DB; for those of 7.5 to 15 HP, disconnect the wiring from terminal DB and the internal relay terminal (see the figure below). Insulate the terminals of the disconnected wires with insulating tape or other materials.

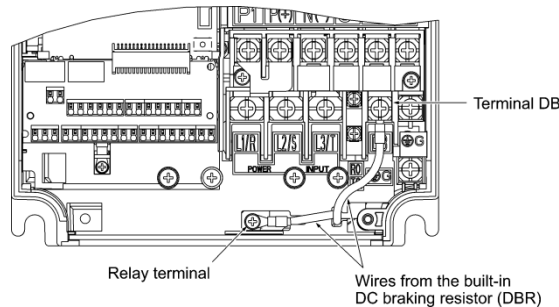

- 2) Connect an optional DBR to terminals P(+) and DB.
The internal relay terminal on inverters of 7.5 to 15 HP is left unused.
- 3) Arrange the DBR and inverter so that the wiring length comes to 16 ft (5 m) or less and twist the two DBR wires or route them together in parallel.

⚠ WARNING
When connecting a DC braking resistor (DBR), never connect it to terminals other than terminals P(+) and DB. Otherwise, a fire could occur.

⑤ DC link bus terminals P(+) and N(-)

Capacity (HP)	Braking transistor	Built-in DC braking resistor (DBR)	Optional devices	Devices and terminals
50 to 1000	None	None	Braking unit	Inverter - Braking unit: P(+) and N(-)
			DC braking resistor (DBR)	Braking unit -DBR: P(+) and DB

1) Connecting an optional braking unit or DC braking resistor (DBR)

Inverters of 50 HP or above require both a braking unit and DBR.

Connect the terminals P(+) and N(-) of a braking unit to those on the inverter. Arrange the inverter and the braking unit so that the wiring length comes to 16 ft (5 m) or less and twist the two wires or route them together in parallel.

Next, connect the terminals P(+) and DB of a DBR to those on the braking unit. Arrange the braking unit and DBR so that the wiring length comes to 33 ft (10 m) or less and twist the two wires or route them together in parallel.

For details about the wiring, refer to the Braking Unit Instruction Manual.

2) Connecting other external devices

A DC link bus of other inverter(s) or a PWM converter is connectable to these terminals.

Note When you need to use the DC link bus terminals P(+) and N(-), consult your TECO-Westinghouse Motor Company representative.

⑥ Switching connectors

■ Power switching connectors (CN UX) (on inverters of 125 HP or above for 460 V)

Inverters of 125 HP or above for 460 V are equipped with a set of switching connectors (male) which should be configured according to the power source voltage and frequency. By factory default, a jumper (female connector) is set to U1. If the power supply to the main power inputs (L1/R, L2/S, L3/T) or the auxiliary fan power input terminals (R1, T1) matches the conditions listed below, change the jumper to U2.

For the switching instructions, see Figures 2.6 and 2.7.

(a) EQ7-4125-C to EQ7-4200-C

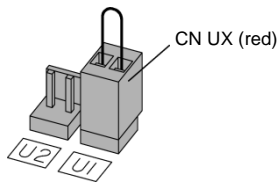
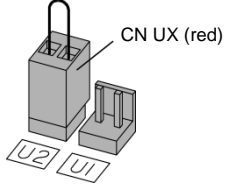
Connector configuration		
Power source voltage	398 to 440 V/50 Hz, 430 to 480 V/60 Hz (Factory default)	380 to 398 V/50 Hz 380 to 430 V/60 Hz

(b) EQ7-4250-C to EQ7-41000-C

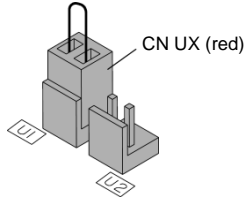
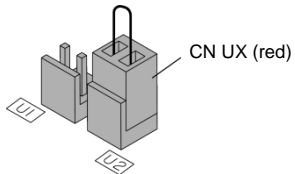
Connector configuration		
Power source voltage	398 to 440 V/50 Hz, 430 to 480 V/60 Hz (Factory default)	380 to 398 V/50 Hz, 380 to 430 V/60 Hz

Note The allowable power input voltage fluctuation is within -15% to +10% of the power source voltage.

■ **Fan power supply switching connectors (CN R and CN W) (on inverters of 60 HP or above for 230 V and those of 125 HP or above for 460 V)**

The standard EQ7 series accepts DC-linked power input in combination with a PWM converter. Inverters of 60 HP or above for 230 V and those of 125 HP or above for 460 V, however, contain AC-driven components such as AC fans. To supply AC power to those components, exchange the CN R and CN W connectors as shown below and connect the AC power line to the auxiliary fan power input terminals (R1, T1).

For the switching instructions, see Figures 2.6 and 2.7.

(a) EQ7-2060-C to EQ7-2125-C, EQ7-4125-C to EQ7-4200-C

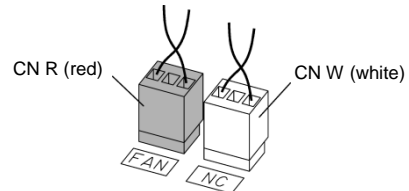
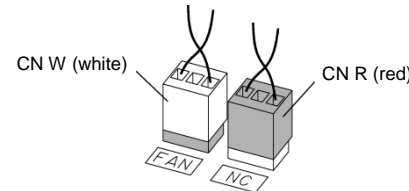
Connector configuration		
Use conditions	When not using terminal R1 or T1 (Factory default)	When using terminals R1 and T1 <ul style="list-style-type: none"> • Feeding the DC-linked power • Combined with a PWM converter

b) EQ7-2150-C, EQ7-4150-C to EQ7-41000-C

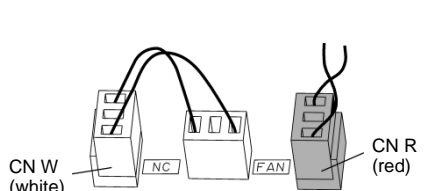
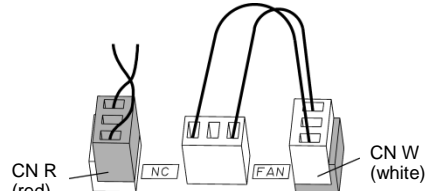
Connector configuration		
Use conditions	When not using terminal R1 or T1 (Factory default)	When using terminals R1 and T1 <ul style="list-style-type: none"> • Feeding the DC-linked power • Combined with a PWM converter

Note By factory default, the fan power supply switching connectors CN R and CN W are set on the **FAN** and **NC** positions, respectively. Do not exchange them unless you drive the inverter with a DC-linked power supply. Wrong configuration of these switching connectors cannot drive the cooling fans, causing a heat sink overheat alarm *Oh1* or a charger circuit alarm *pbf*.

■ **Location of the switching connectors**

The switching connectors are located on the power printed circuit board (power PCB) as shown below.

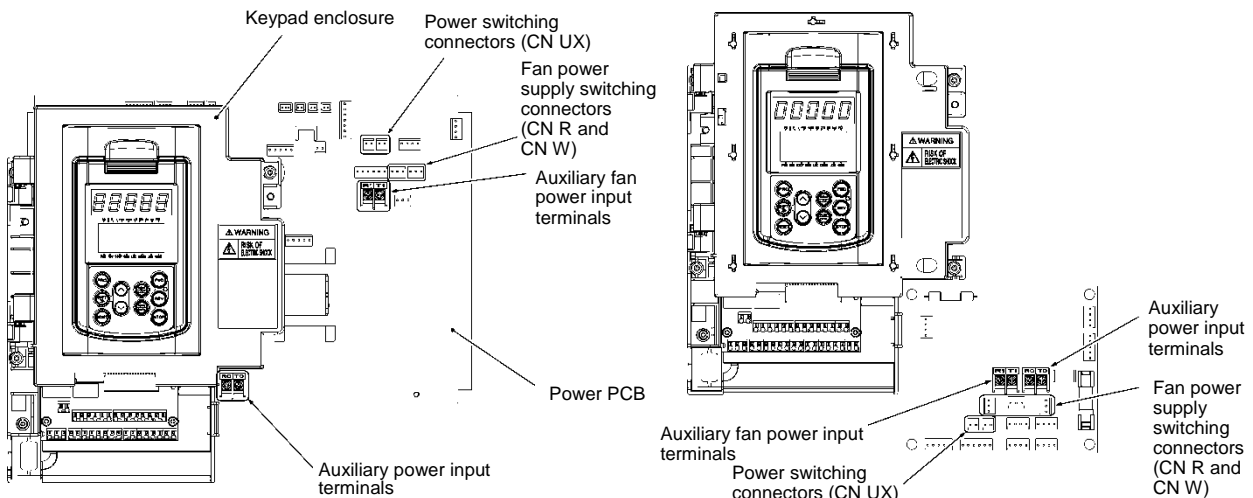

(a) EQ7-2060-C to EQ7-2125-C, EQ7-4125-C to EQ7-4200-C

(b) EQ7-2150-C, EQ7-4250-C to EQ7-41000-C

Figure 2.6 Location of Switching Connectors and Auxiliary Power Input Terminals

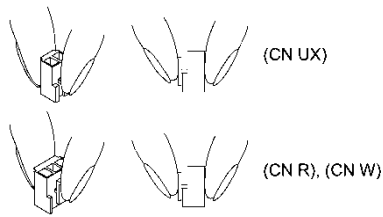

Figure 2.7 Inserting/Removing the Jumpers

Note To remove each of the jumpers, pinch its upper side between your fingers, unlock its fastener, and pull it up. When mounting it, fit the jumper over the connector until it snaps into place.

⑦ Main circuit power input terminals L1/R, L2/S, and L3/T (three-phase input)

The three-phase input power lines are connected to these terminals.

- 1) For safety, make sure that the molded case circuit breaker (MCCB) or magnetic contactor (MC) is turned OFF before wiring the main circuit power input terminals.
- 2) Connect the main circuit power supply wires (L1/R, L2/S and L3/T) to the input terminals of the inverter via an MCCB or residual-current-operated protective device (RCD)/earth leakage circuit breaker (ELCB)*, and an MC if necessary.

It is not necessary to align phases of the power supply wires and the input terminals of the inverter with each other.

* With overcurrent protection

Tip It is recommended to insert a manually operable magnetic contactor (MC) that allows you to disconnect the inverter from the power supply in an emergency (e.g., when the protective function is activated), preventing a failure or accident from causing secondary disasters.

⑧ Auxiliary control power input terminals R0 and T0 (on inverters of 2 HP or above)

In general, the inverter runs normally without power supplied to the auxiliary control power input terminals R0 and T0. If the inverter main power is shut down, however, no power is supplied to the control circuit so that the inverter cannot issue a variety of output signals or display on the keypad.

To retain an alarm output signal **ALM** issued on inverter's programmable output terminals by the protective function or to keep the keypad alive even if the main power has shut down, connect the auxiliary control power input terminals R0 and T0 to the power supply lines. If a magnetic contactor (MC) is installed in the inverter's primary circuit, connect the primary circuit of the MC to these terminals R0 and T0.

Terminal rating:

200 to 240 VAC, 50/60 Hz, Maximum current 1.0 A (230 V series with 40 HP or below)

200 to 230 VAC, 50/60 Hz, Maximum current 1.0 A (230 V series with 50 HP or above)

380 to 480 VAC, 50/60 Hz, Maximum current 0.5 A (460 V series)

Note When introducing a residual-current-operated protective device (RCD)/earth leakage circuit breaker (ELCB), connect its output (secondary) side to terminals R0 and T0. Connecting its input (primary) side to those terminals causes the RCD/ELCB to malfunction since the input power voltage to the inverter is three-phase but the one to terminals R0 and T0 is single-phase. To avoid such problems, be sure to insert an isolation transformer or auxiliary B contacts of a magnetic contactor in the location shown in Figure 2.8.

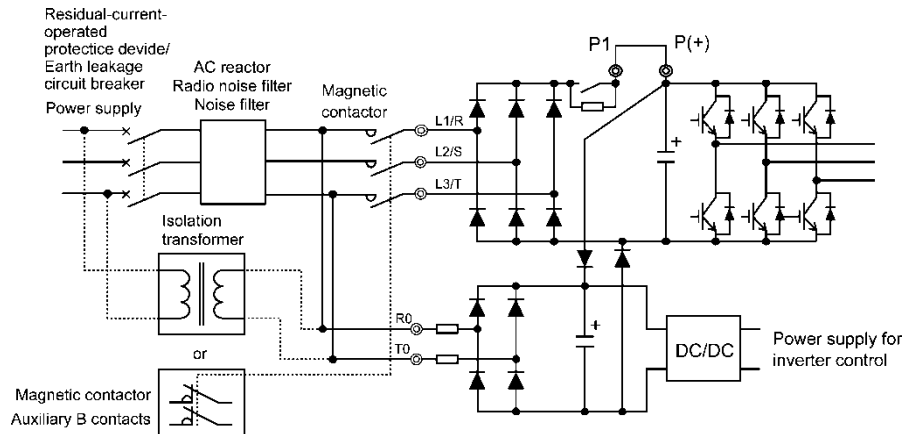

Figure 2.8 Connection Example of Residual-current-operated Protective Device (RCD)/Earth Leakage Circuit Breaker (ELCB)

Note When connecting a PWM converter with an inverter, do not connect the power supply line directly to terminals R0 and T0. If a PWM is to be connected, insert an isolation transformer or auxiliary B contacts of a magnetic contactor at the power supply side.
 For connection examples at the PWM converter side, refer to the PWM Converter Instruction Manual.

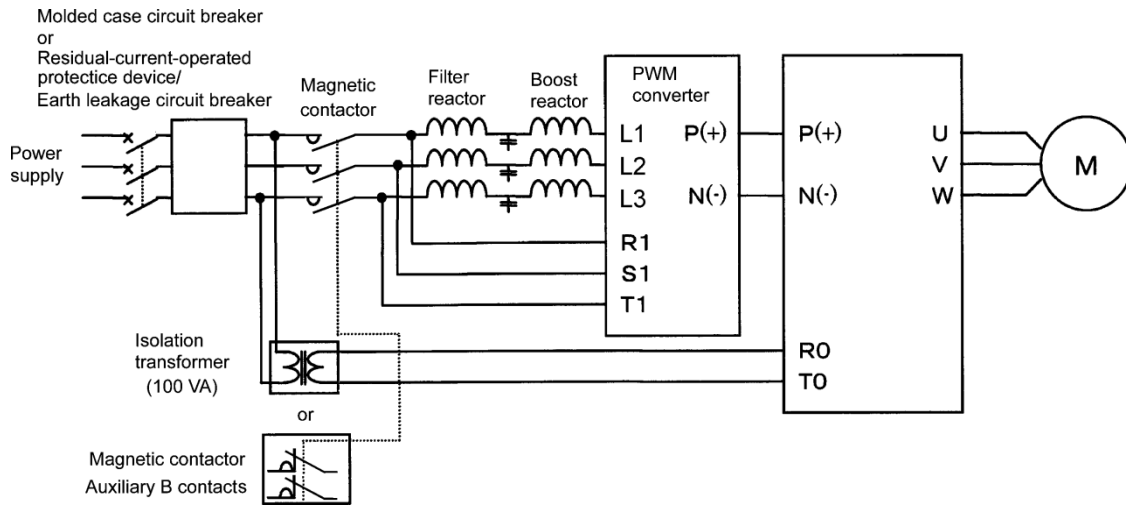

Figure 2.9 Connection Example of PWM Converter

⑨ Auxiliary fan power input terminals R1 and T1

Inverters of 60 HP or above for 230 V and those of 125 HP or above for 460 V are equipped with terminals R1 and T1. Only if the inverter works with the DC-linked power input whose source is a PWM converter, these terminals are used to feed AC power to the fans, while they are not used in any power system of ordinary configuration.

In this case, set up the fan power supply switching connectors (CN R and CN W).

Terminal rating:

- 200 to 220 VAC/50 Hz, 200 to 230 VAC/60 Hz, Maximum current 1.0 A (230 V series with 60 HP or above)
- 380 to 440 VAC/50 Hz, 380 to 480 VAC/60 Hz, Maximum current 1.0 A (460 V series with 125 to 800 HP)
- 380 to 440 VAC/50 Hz, 380 to 480 VAC/60 Hz, Maximum current 2.0 A (460 V series with 900 and 1000 HP)

2.3.5 Wiring for control circuit terminals

This section shows connection diagrams with the Enable input function used.

⚠ WARNING
<p>In general, the covers of the control signal wires are not specifically designed to withstand a high voltage (i.e., reinforced insulation is not applied). Therefore, if a control signal wire comes into direct contact with a live conductor of the main circuit, the insulation of the cover might break down, which would expose the signal wire to a high voltage of the main circuit. Make sure that the control signal wires will not come into contact with live conductors of the main circuit.</p> <p>Failure to observe these precautions could cause electric shock or an accident.</p>
⚠ CAUTION
<p>Noise may be emitted from the inverter, motor and wires. Take appropriate measures to prevent the nearby sensors and devices from malfunctioning due to such noise.</p> <p>An accident could occur.</p>

■ Connecting/disconnecting wires to/from a control circuit terminal of spring (screwless) type

- ① Strip the wire end by 8 to 10 mm/0.31 to 0.39 inch as shown below.

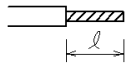
Strip length of wire end	8 to 10 mm 0.31 to 0.39 inch	
Type of screwdriver (tip shape)	Flat (0.6 × 3.5 mm/0.024 × 0.14 inch)	

Note For strand wires, the strip length specified above should apply after twisting of them.
If the strip length is out of the specified range, the wire may not be firmly clamped or may be short-circuited with other wires.

- ② Twist the end of the stripped wires for easy insertion and insert it firmly into the wire inlet on the control circuit terminal. If the insertion is difficult, hold down the clamp release button on the terminal with a flat screwdriver.
- ③ When disconnecting the wires from the terminal, hold down the clamp release button on the terminal with a flat screwdriver and pull out the wires. Connecting wire to terminal disconnecting wire from terminal

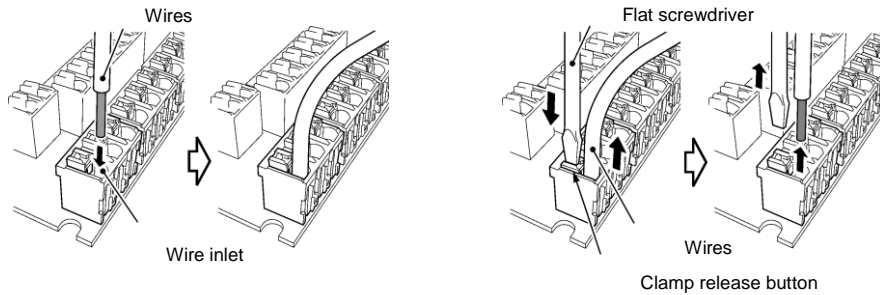

Table 2.7 lists the symbols, names and functions of the control circuit terminals. The wiring to the control circuit terminals differs depending upon the setting of the function codes, which reflects the use of the inverter. Route wires properly to reduce the influence of noise.

Table 2.7 Symbols, Names and Functions of the Control Circuit Terminals

Classification	Symbol	Name	Functions
Analog input	[13]	Power supply for the potentiometer	Power supply (+10 VDC) for an external frequency command potentiometer (Variable resistor: 1 to 5kΩ) The potentiometer of 1/2 W rating or more should be connected.
	[12]	Analog setting voltage input	<ol style="list-style-type: none"> The frequency is commanded according to the external voltage input. <ul style="list-style-type: none"> 0 to ±10 VDC/0 to ±100% (Normal operation) +10 to 0 VDC/0 to 100% (Inverse operation) In addition to frequency setting, PID command, PID feedback signal, auxiliary frequency command setting, ratio setting, torque limiter level setting, or analog input monitor can be assigned to this terminal. Hardware specifications <ul style="list-style-type: none"> Input impedance: 22kΩ The maximum input is ±15 VDC, however, the voltage higher than ±10 VDC is handled as ±10 VDC. Inputting a bipolar analog voltage (0 to ±10 VDC) to terminal [12] requires setting function code C35 to "0."
	[C1]	Analog setting current input	<ol style="list-style-type: none"> The frequency is commanded according to the external current input. <ul style="list-style-type: none"> 4 to 20 mA DC/0 to 100% (Normal operation) 20 to 4 mA DC/0 to 100 % (Inverse operation) In addition to frequency setting, PID command, PID feedback signal, auxiliary frequency command setting, ratio setting, torque limiter level setting, or analog input monitor can be assigned to this terminal. Hardware specifications <ul style="list-style-type: none"> Input impedance: 250Ω The maximum input is +30 mA DC, however, the current larger than +20 mA DC is handled as +20 mA DC.
		PTC/NTC thermistor input	<ol style="list-style-type: none"> Connects PTC (Positive Temperature Coefficient)/NTC (Negative Temperature Coefficient) thermistor for motor protection. Ensure that the slide switch SW5 on the control PCB is turned to the PTC/NTC position (see section 2.3.6 "Setting up the slide switches"). The figure shown at the right illustrates the internal circuit diagram where SW5 (switching the input of terminal [C1] between C1 and PTC/NTC) is turned to the PTC/NTC position. For details on SW5, refer to Instruction manual section 2.3.6 "Setting up the slide switches." In this case, you must change data of the function code H26.
			<p>The diagram shows the internal circuit for the PTC/NTC thermistor input. A PTC/NTC thermistor is connected to terminal [C1]. Terminal [13] is connected to a DC +10 V supply through a 27kΩ resistor. Terminal [11] is connected to a 0 V ground. The circuit includes a comparator (H27) and an external alarm (H26). The comparator's input is connected to terminal [C1] and the 27kΩ resistor. The comparator's output is connected to the external alarm (H26).</p>
	[V2]	Analog setting voltage input	<ol style="list-style-type: none"> The frequency is commanded according to the external voltage input. <ul style="list-style-type: none"> 0 to ±10 VDC/0 to ±100 % (Normal operation) +10 to 0 VDC/0 to 100% (Inverse operation) In addition to frequency setting, PID command, PID feedback signal, auxiliary frequency command setting, ratio setting, torque limiter level setting, or analog input monitor can be assigned to this terminal. Hardware specifications <ul style="list-style-type: none"> Input impedance: 22kΩ The maximum input is ±15 VDC, however, the voltage higher than ±10 VDC is handled as ±10 VDC. Inputting a bipolar analog voltage (0 to ±10 VDC) to terminal [V2] requires setting function code C45 to "0."
	[11]	Analog common	Common for analog input/output signals ([13], [12], [C1], [V2], [FM1] and [FM2]). Isolated from terminals [CM] and [CMY].

Table 2.7 Symbols, Names and Functions of the Control Circuit Terminals (Continued)

Classification	Symbol	Name	Functions																														
			<ul style="list-style-type: none"> - Since low level analog signals are handled, these signals are especially susceptible to the external noise effects. Route the wiring as short as possible (within 66 ft (20 m)) and use shielded wires. In principle, ground the shielded sheath of wires; if effects of external inductive noises are considerable, connection to terminal [11] may be effective. As shown in Figure 2.11, be sure to ground the single end of the shield to enhance the shield effect. - Use a twin-contact relay for low level signals if the relay is used in the control circuit. Do not connect the relay's contact to terminal [11]. - When the inverter is connected to an external device outputting the analog signal, the external device may malfunction due to electric noise generated by the inverter. If this happens, according to the circumstances, connect a ferrite core (a toroidal core or equivalent) to the device outputting the analog signal or connect a capacitor having the good cut-off characteristics for high frequency between control signal wires as shown in Figure 2.12. - Do not apply a voltage of +7.5 VDC or higher to terminal [C1]. Doing so could damage the internal control circuit. 																														
			<div style="display: flex; justify-content: space-around;"> <div style="text-align: center;">  <p>Figure 2.11 Connection of Shielded Wire</p> </div> <div style="text-align: center;">  <p>Figure 2.12 Example of Electric Noise Reduction</p> </div> </div>																														
Digital input	[X1]	Digital input 1	<p>(1) Various signals such as "Coast to a stop," "Enable external alarm trip," and "Select multi-frequency" can be assigned to terminals [X1] to [X7], [FWD] and [REV] by setting function codes E01 to E07, E98, and E99. For details, refer to Chapter 4, Section 4.2 "Details of Function Codes."</p> <p>(2) Input mode, i.e. SINK/SOURCE, is changeable by using the slide switch SW1. (Refer to Instruction manual section 2.3.6 "Setting up the slide switches.")</p> <p>(3) Switches the logic value (1/0) for ON/OFF of the terminals [X1] to [X7], [FWD], or [REV]. If the logic value for ON of the terminal [X1] is 1 in the normal logic system, for example, OFF is 1 in the negative logic system and vice versa.</p> <p>(4) Digital input terminal [X7] can be defined as a pulse train input terminal with the function codes.</p> <p>Maximum wiring length 20 m/66 ft</p> <p>Maximum input pulse 30 kHz: When connected to a pulse generator with open collector transistor output (Needs a pull-up or pull-down resistor. See notes on page 2-22.)</p> <p>100 kHz: When connected to a pulse generator with complementary transistor output</p> <p>For the settings of the function codes, refer to Chapter 4 "FUNCTION CODES."</p> <p>(Digital input circuit specifications)</p> <div style="display: flex; justify-content: space-between;"> <div style="width: 60%;">  <p>Figure 2.13 Digital Input Circuit</p> </div> <div style="width: 35%;"> <table border="1"> <thead> <tr> <th>Item</th> <th></th> <th>Min.</th> <th>Max.</th> </tr> </thead> <tbody> <tr> <td rowspan="2">Operating voltage (SINK)</td> <td>ON level</td> <td>0 V</td> <td>2 V</td> </tr> <tr> <td>OFF level</td> <td>22 V</td> <td>27 V</td> </tr> <tr> <td rowspan="2">Operating voltage (SOURCE)</td> <td>ON level</td> <td>22 V</td> <td>27 V</td> </tr> <tr> <td>OFF level</td> <td>0 V</td> <td>2 V</td> </tr> <tr> <td colspan="2">Operating current at ON (Input voltage is at 0 V) (For [X7])</td> <td>2.5 mA</td> <td>5 mA</td> </tr> <tr> <td colspan="2"></td> <td>(9.7 mA)</td> <td>(16 mA)</td> </tr> <tr> <td colspan="2">Allowable leakage current at OFF</td> <td>-</td> <td>0.5 mA</td> </tr> </tbody> </table> </div> </div>	Item		Min.	Max.	Operating voltage (SINK)	ON level	0 V	2 V	OFF level	22 V	27 V	Operating voltage (SOURCE)	ON level	22 V	27 V	OFF level	0 V	2 V	Operating current at ON (Input voltage is at 0 V) (For [X7])		2.5 mA	5 mA			(9.7 mA)	(16 mA)	Allowable leakage current at OFF		-	0.5 mA
Item		Min.		Max.																													
Operating voltage (SINK)	ON level	0 V		2 V																													
	OFF level	22 V		27 V																													
Operating voltage (SOURCE)	ON level	22 V		27 V																													
	OFF level	0 V		2 V																													
Operating current at ON (Input voltage is at 0 V) (For [X7])		2.5 mA		5 mA																													
		(9.7 mA)		(16 mA)																													
Allowable leakage current at OFF		-	0.5 mA																														
	[X2]	Digital input 2																															
	[X3]	Digital input 3																															
	[X4]	Digital input 4																															
	[X5]	Digital input 5																															
	[X6]	Digital input 6																															
	[X7]	Digital input 7																															
	[FWD]	Run forward command																															
	[REV]	Run reverse command																															

Table 2.7 Symbols, Names and Functions of the Control Circuit Terminals (Continued)

Classification	Symbol	Name	Functions																			
Digital input	[EN1] [EN2]	Enable inputs	<p>(1) Turning off the circuit between terminals [EN1] and [PLC] or terminals [EN2] and [PLC] stops the inverter's output transistor. (Safe Torque Off: STO)</p> <p>(2) These terminals are exclusively used for the source mode input and cannot be switched to the sink mode.</p> <p>(3) If either one of these input terminals is kept OFF for 50 ms or more, the inverter interprets it as a discrepancy, causing an alarm <i>etc.</i> This alarm state can be cleared only by turning the inverter power off and on clears this alarm.</p> <p>For details of connection to this terminal and precautions, refer to User Manual Chapter 9, Section 9.4 "Compliance with EN954-1, Category 3."</p> <p><Terminal [EN1] [EN2] circuit specification></p> <table border="1" data-bbox="889 573 1382 835"> <thead> <tr> <th colspan="2">Item</th> <th>Min.</th> <th>Max.</th> </tr> </thead> <tbody> <tr> <td rowspan="2">Operating voltage</td> <td>ON level</td> <td>22 V</td> <td>27 V</td> </tr> <tr> <td>OFF level</td> <td>0 V</td> <td>2 V</td> </tr> <tr> <td colspan="2">Operating current at ON (Input voltage is at 27 V)</td> <td>2.5 mA</td> <td>5 mA</td> </tr> <tr> <td colspan="2">Allowable leakage current at OFF</td> <td>-</td> <td>0.5 mA</td> </tr> </tbody> </table>	Item		Min.	Max.	Operating voltage	ON level	22 V	27 V	OFF level	0 V	2 V	Operating current at ON (Input voltage is at 27 V)		2.5 mA	5 mA	Allowable leakage current at OFF		-	0.5 mA
	Item		Min.	Max.																		
	Operating voltage	ON level	22 V	27 V																		
OFF level		0 V	2 V																			
Operating current at ON (Input voltage is at 27 V)		2.5 mA	5 mA																			
Allowable leakage current at OFF		-	0.5 mA																			
[PLC]	PLC signal power	<p>(1) Connects to the power supply of PLC output signals. Rated voltage: +24 VDC (Allowable range: +22 to +27 VDC), Maximum 100 mA DC</p> <p>(2) This terminal also supplies power to the load connected to the transistor output terminals. Refer to "Transistor output" described later in this table for more.</p>																				
[CM]	Digital input common	<p>Common terminal for digital input signals</p> <p>This terminal is electrically isolated from the terminals [11]s and [CMY].</p>																				
Tip	<p>■ Using a relay contact to turn [X1] to [X7], [FWD], or [REV] ON or OFF</p> <p>Figure 2.14 shows two examples of a circuit that uses a relay contact to turn control signal input [X1] to [X7], [FWD], or [REV] ON or OFF. In circuit (a), the slide switch SW1 is turned to SINK, whereas in circuit (b) it is turned to SOURCE.</p> <p>Note: To configure this kind of circuit, use a highly reliable relay.</p> <p>(a) With the switch turned to SINK</p> <p>(b) With the switch turned to SOURCE</p> <p>Figure 2.14 Circuit Configuration Using a Relay Contact</p>																					
Tip	<p>■ Using a programmable logic controller (PLC) to turn [X1] to [X7], [FWD], or [REV] ON or OFF</p> <p>Figure 2.15 shows two examples of a circuit that uses a programmable logic controller (PLC) to turn control signal input [X1] to [X7], [FWD], or [REV] ON or OFF. In circuit (a), the slide switch SW1 is turned to SINK, whereas in circuit (b) it is turned to SOURCE.</p> <p>In circuit (a) below, short-circuiting or opening the transistor's open collector circuit in the PLC using an external power supply turns ON or OFF control signal [X1] to [X7], [FWD], or [REV]. When using this type of circuit, observe the following:</p> <ul style="list-style-type: none"> - Connect the + node of the external power supply (which should be isolated from the PLC's power) to terminal [PLC] of the inverter. - Do not connect terminal [CM] of the inverter to the common terminal of the PLC. 																					

Table 2.7 Symbols, Names and Functions of the Control Circuit Terminals (Continued)

Classification	Symbol	Name	Functions																							
Digital input			<div style="display: flex; justify-content: space-around;"> <div data-bbox="277 281 766 577"> <p>(a) With the switch turned to SINK</p> </div> <div data-bbox="878 281 1367 577"> <p>(b) With the switch turned to SOURCE</p> </div> </div> <p style="text-align: center;">Figure 2.15 Circuit Configuration Using a PLC</p> <p>For details about the slide switch setting, refer to Instruction manual for section 2.3.6 "Setting up the slide switches."</p> <p>Note</p> <ul style="list-style-type: none"> For inputting a pulse train through the digital input terminal [X7] <ul style="list-style-type: none"> Inputting from a pulse generator with an open collector transistor output <p>Stray capacity on the wiring between the pulse generator and the inverter may disable transmission of the pulse train. As a countermeasure against this problem, insert a pull-up resistor between the open collector output signal (terminal [X7]) and the power source terminal (terminal [PLC]) if the switch selects the SINK mode input; insert a pull-down resistor between the output signal and the digital common terminal (terminal [CM]) if the switch selects the SOURCE mode input.</p> <p>A recommended pull-up/down resistor is 1kΩ 2 W. Check if the pulse train is correctly transmitted because stray capacity is significantly affected by the wire types and wiring conditions.</p>																							
	Analog output	[FM1] [FM2]	Analog monitor	<p>Both terminals output monitor signals for analog DC voltage (0 to +10 V) or analog DC current (+4 to +20 mA). The output form (VO/IO) for each of [FM1] and [FM2] can be switched with the slide switches on the control PCB and the function codes, as listed below.</p> <table border="1" data-bbox="516 1045 1360 1226"> <thead> <tr> <th rowspan="2">Terminal</th> <th rowspan="2">Terminal function is specified by:</th> <th colspan="2">Output form</th> <th rowspan="2">Content is specified by:</th> </tr> <tr> <th>Analog DC voltage</th> <th>Analog DC current</th> </tr> </thead> <tbody> <tr> <td rowspan="2">[FM1]</td> <td>Slide switch SW4</td> <td>VO1</td> <td>IO1</td> <td rowspan="2">Function code F31</td> </tr> <tr> <td>Function code F29</td> <td>0</td> <td>1</td> </tr> <tr> <td rowspan="2">[FM2]</td> <td>Slide switch SW6</td> <td>VO2</td> <td>IO2</td> <td rowspan="2">Function code F35</td> </tr> <tr> <td>Function code F32</td> <td>0</td> <td>1</td> </tr> </tbody> </table> <p>The signal content can be selected from the following with function codes F31 and F35.</p> <ul style="list-style-type: none"> Output frequency Output torque PID feedback amount Universal AO PID command Output current Load factor Speed (PG feedback value) Motor output PID output Output voltage Input power DC link bus voltage Cal bration <p>* Input impedance of the external device: Min. 5kΩ (at 0 to 10 VDC output) (While the terminal is outputting 0 to 10 VDC, it is capable of driving up to two analog voltmeters with 10 kΩ impedance.)</p> <p>* Input impedance of the external device: Max. 500Ω (at 4 to 20 mA DC output)</p> <p>* Adjustable range of the gain: 0 to 300%</p>	Terminal	Terminal function is specified by:	Output form		Content is specified by:	Analog DC voltage	Analog DC current	[FM1]	Slide switch SW4	VO1	IO1	Function code F31	Function code F29	0	1	[FM2]	Slide switch SW6	VO2	IO2	Function code F35	Function code F32	0
Terminal		Terminal function is specified by:	Output form				Content is specified by:																			
	Analog DC voltage		Analog DC current																							
[FM1]	Slide switch SW4	VO1	IO1	Function code F31																						
	Function code F29	0	1																							
[FM2]	Slide switch SW6	VO2	IO2	Function code F35																						
	Function code F32	0	1																							
	[11]	Analog common	<p>Two common terminals for analog input and output signals.</p> <p>These terminals are electrically isolated from terminals [CM] and [CMY].</p>																							

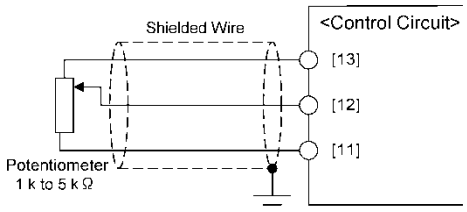
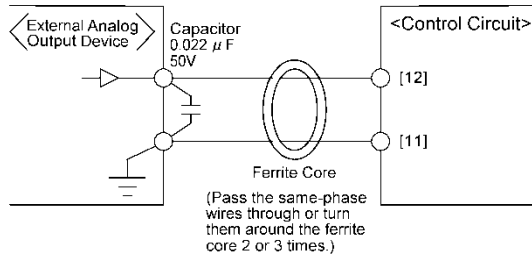
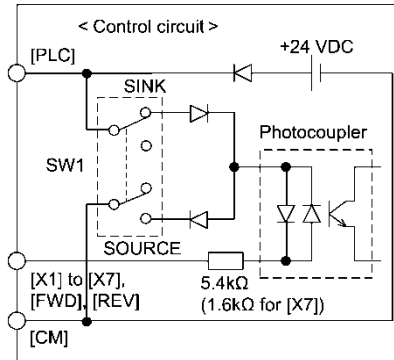
Table 2.7 Symbols, Names and Functions of the Control Circuit Terminals (Continued)

Classification	Symbol	Name	Functions														
Transistor output	[Y1]	Transistor output 1	(1) Various signals such as inverter running, speed/freq. arrival and overload early warning can be assigned to any terminals, [Y1] to [Y4] by setting function code E20 to E24. Refer to Chapter 4, Section 4.2 "Details of Function Codes" for details. (2) Switches the logic value (1/0) for ON/OFF of the terminals between [Y1] to [Y4], and [CMY]. If the logic value for ON between [Y1] to [Y4] and [CMY] is 1 in the normal logic system, for example, OFF is 1 in the negative logic system and vice versa.														
	[Y2]	Transistor output 2															
	[Y3]	Transistor output 3	(Transistor output circuit specification)  <table border="1" data-bbox="1003 514 1372 688"> <thead> <tr> <th colspan="2">Item</th> <th>Max.</th> </tr> </thead> <tbody> <tr> <td rowspan="2">Operation voltage</td> <td>ON level</td> <td>2 V</td> </tr> <tr> <td>OFF level</td> <td>27 V</td> </tr> <tr> <td colspan="2">Maximum current at ON</td> <td>50 mA</td> </tr> <tr> <td colspan="2">Leakage current at OFF</td> <td>0.1 mA</td> </tr> </tbody> </table>	Item		Max.	Operation voltage	ON level	2 V	OFF level	27 V	Maximum current at ON		50 mA	Leakage current at OFF		0.1 mA
	Item		Max.														
	Operation voltage	ON level	2 V														
OFF level		27 V															
Maximum current at ON		50 mA															
Leakage current at OFF		0.1 mA															
[Y4]	Transistor output 4	Note - When a transistor output drives a control relay, connect a surge-absorbing diode across relay's coil terminals. - When any equipment or device connected to the transistor output needs to be supplied with DC power, feed the power (+24 VDC: allowable range: +22 to +27 VDC, 100 mA max.) through the [PLC] terminal. Short-circuit between the terminals [CMY] and [CM] in this case.															
[CMY]	Transistor output common	Common terminal for transistor output signals This terminal is electrically isolated from terminals [CM] and [11]s.															
<p>Tip ■ Connecting programmable logic controller (PLC) to terminal [Y1], [Y2], [Y3] or [Y4]</p> <p>Figure 2.17 shows two examples of circuit connection between the transistor output of the inverter's control circuit and a PLC. In example (a), the input circuit of the PLC serves as a SINK for the control circuit output, whereas in example (b), it serves as a SOURCE for the output.</p>			 <p>(a) PLC serving as SINK</p> <p>(b) PLC serving as SOURCE</p> <p>Figure 2.17 Connecting PLC to Control Circuit</p>														
Relay output	[Y5A/C]	General purpose relay output	(1) A general-purpose relay contact output usable as well as the function of the transistor output terminal [Y1], [Y2], [Y3] or [Y4]. Contact rating: <u>250 VAC 0.3 A, cos φ = 0.3</u> , <u>48 VDC, 0.5 A</u> (2) Switching of the normal/negative logic output is applicable to the following two contact output modes: "Active ON" (Terminals [Y5A] and [Y5C] are closed (excited) if the signal is active.) and "Active OFF" (Terminals [Y5A] and [Y5C] are opened (non-excited) if the signal is active while they are normally closed.).														

Table 2.7 Symbols, Names and Functions of the Control Circuit Terminals (Continued)

Classification	Symbol	Name	Functions
Relay output	[30A/B/C]	Alarm relay output (for any error)	<p>(1) Outputs a contact signal (SPDT) when a protective function has been activated to stop the motor. Contact rating: $250 \text{ VAC}, 0.3\text{A}, \cos \phi = 0.3$, $48 \text{ VDC}, 0.5\text{A}$</p> <p>(2) Any one of output signals assigned to terminals [Y1] to [Y4] can also be assigned to this relay contact to use it for signal output.</p> <p>(3) Switching of the normal/negative logic output is applicable to the following two contact output modes: "Active ON" (Terminals [30A] and [30C] are closed (excited) if the signal is active.) and "Active OFF" (Terminals [30A] and [30C] are opened (non-excited) if the signal is active while they are normally closed.).</p>
Communication	[DX+]/ [DX-]/ [SD]	RS-485 communications port 2 (Terminals on control PCB)	A communications port transmits data through the RS-485 multipoint protocol between the inverter and a computer or other equipment such as a PLC. (For setting of the terminating resistor, refer to Section 2.3.6 "Setting up the slide switches.")
	RJ-45 connector for the keypad	RS-485 communications port 1 (Standard RJ-45 connector)	<p>(1) Used to connect the inverter with the keypad. The inverter supplies the power to the keypad through the pins specified below. The extension cable for remote operation also uses wires connected to these pins for supplying the keypad power.</p> <p>(2) Remove the keypad from the standard RJ-45 connector and connect the RS-485 communications cable to control the inverter through the PC or PLC (Programmable Logic Controller). For setting of the terminating resistor, refer to Section 2.3.6 "Setting up the slide switches."</p> <div style="text-align: center;"> <p>Figure 2.18 RJ-45 Connector and its Pin Assignment*</p> </div> <p>* Pins 1, 2, 7, and 8 are exclusively assigned to power lines for the keypad, so do not use those pins for any other equipment.</p>

Wiring for control circuit terminals

For EQ72125-C, EQ72150-C and EQ74250-C to EQ741000-C

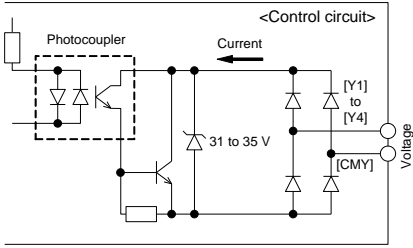
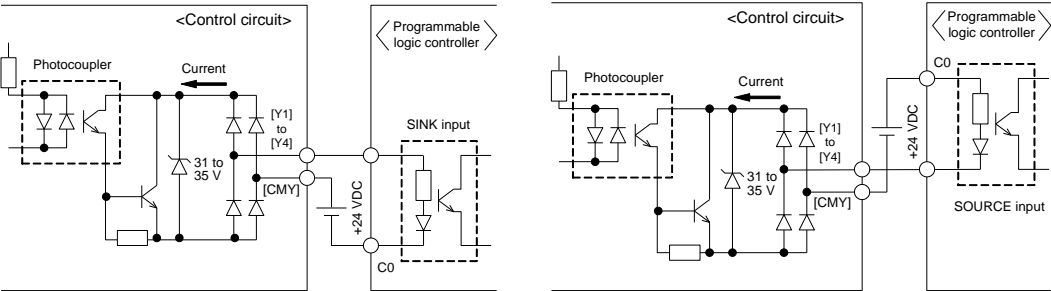
- (1) As shown in Figure 2.19, route the control circuit wires along the left side panel to the outside of the inverter.
- (2) Secure those wires to the wiring support, using a cable tie (e.g., Insulok) with 0.15 inch (3.8 mm) or less in width and 0.059 inch (1.5 mm) or less in thickness.

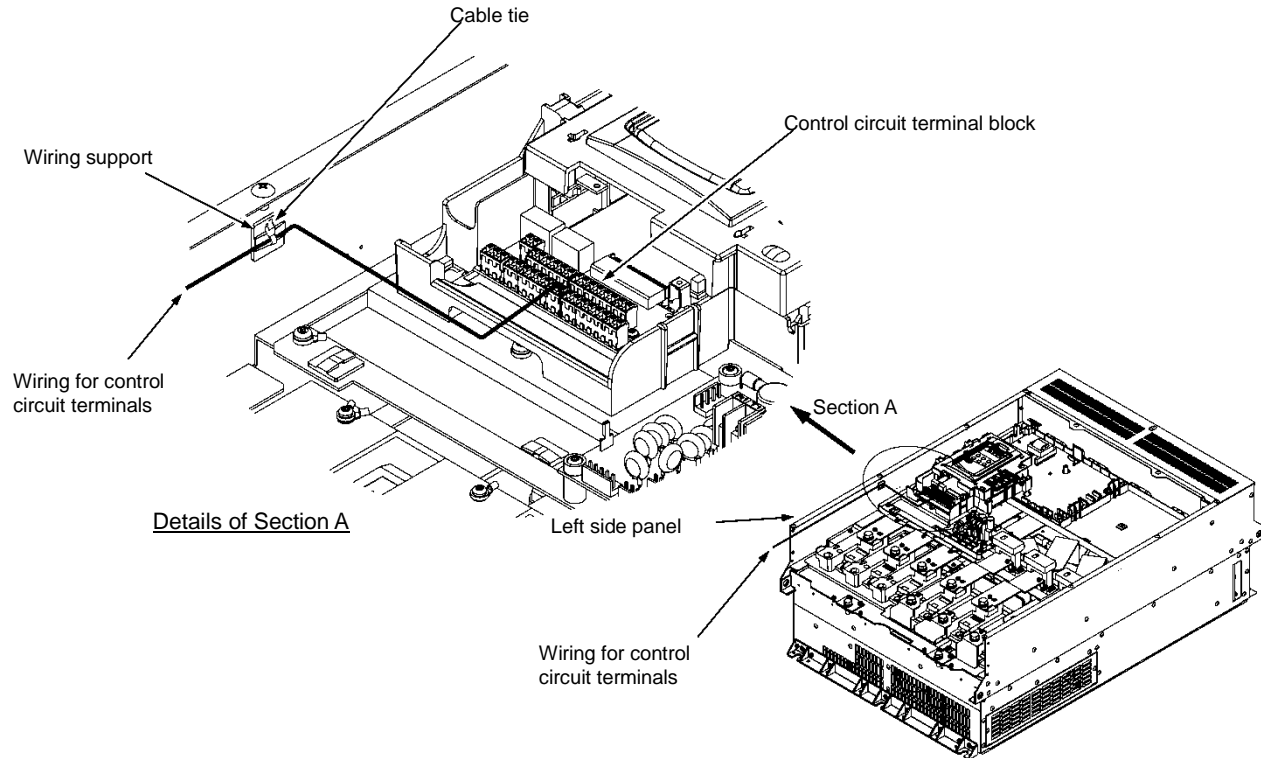

Figure 2.19 Wiring Route and Fixing Position for the Control Circuit Wires

- Note**
- Route the wiring of the control circuit terminals as far from the wiring of the main circuit as possible. Otherwise electric noise may cause malfunctions.
 - Fix the control circuit wires with a cable tie inside the inverter to keep them away from the live parts of the main circuit (such as the terminal block of the main circuit).

2.3.6 Setting up the slide switches

⚠ WARNING ⚠

Before changing the switches or touching the control circuit terminal symbol plate, **turn OFF the power and wait at least five minutes for inverters of 40 HP or below, or at least ten minutes for those of 50 HP or above.** Make sure that the LED monitor and charging lamp are turned OFF. Further, make sure, using a multimeter or a similar instrument, that the DC link bus voltage between the terminals P(+) and N(-) has dropped to the safe level (+25 VDC or below).

An electric shock may result if this warning is not heeded as there may be some residual electric charge in the DC bus capacitor even after the power has been turned OFF.

Switching the slide switches located on the control PCB allows you to customize the operation mode of the analog output terminals, digital I/O terminals, and communications ports. The locations of those switches are shown in Figure 2.20.

To access the slide switches, remove the front cover so that you can see the control PCB. For inverters of 50 HP or above, open also the keypad enclosure.

📖 For details on how to remove the front cover and how to open and close the keypad enclosure, refer to Section 2.3.1 "Removing and mounting the front cover and the wiring guide."

Table 2.8 lists function of each slide switch.

Table 2.8 Function of Each Slide Switch

Switch	Function																			
SW1	<p>Switches the service mode of the digital input terminals between SINK and SOURCE.</p> <ul style="list-style-type: none"> This switches the input mode of digital input terminals [X1] to [X7], [FWD] and [REV] to be used as the SINK or SOURCE mode. The factory default is SINK. 																			
SW2	<p>Switches the terminating resistor of RS-485 communications port on the inverter ON and OFF. (RS-485 communications port 2, on the control PCB)</p> <ul style="list-style-type: none"> If the inverter is connected to the RS-485 communications network as a terminating device, turn SW2 to ON. 																			
SW3	<p>Switches the terminating resistor of RS-485 communications port on the inverter ON and OFF. (RS-485 communications port 1, for connecting the keypad)</p> <ul style="list-style-type: none"> To connect a keypad to the inverter, turn SW3 to OFF. (Factory default) If the inverter is connected to the RS-485 communications network as a terminating device, turn SW3 to ON. 																			
SW4/SW6	<p>Switches the output form of analog output terminals [FM1] and [FM2] between voltage and current.</p> <p>When changing the setting of SW4 and SW6, also change the data of function codes F29 and F32, respectively.</p> <table border="1"> <thead> <tr> <th rowspan="2">Output form</th> <th colspan="2">[FM1]</th> <th colspan="2">[FM2]</th> </tr> <tr> <th>SW4</th> <th>F29 data</th> <th>SW6</th> <th>F32 data</th> </tr> </thead> <tbody> <tr> <td>Voltage output (Factory default)</td> <td>VO1</td> <td>0</td> <td>VO2</td> <td>0</td> </tr> <tr> <td>Current output</td> <td>IO1</td> <td>1</td> <td>IO2</td> <td>1</td> </tr> </tbody> </table>	Output form	[FM1]		[FM2]		SW4	F29 data	SW6	F32 data	Voltage output (Factory default)	VO1	0	VO2	0	Current output	IO1	1	IO2	1
Output form	[FM1]		[FM2]																	
	SW4	F29 data	SW6	F32 data																
Voltage output (Factory default)	VO1	0	VO2	0																
Current output	IO1	1	IO2	1																
SW5	<p>Switches the property of the analog input terminal [C1] between analog setting current input, PTC thermistor input, and NTC thermistor input.</p> <p>When changing this switch setting, also change the data of function code H26.</p> <table border="1"> <thead> <tr> <th>Function</th> <th>SW5</th> <th>H26 data</th> </tr> </thead> <tbody> <tr> <td>Analog setting current input (Factory default)</td> <td>C1</td> <td>0</td> </tr> <tr> <td>PTC thermistor input</td> <td>PTC/NTC</td> <td>1 (alarm) or 2 (warning)</td> </tr> <tr> <td>NTC thermistor input</td> <td>PTC/NTC</td> <td>3</td> </tr> </tbody> </table>	Function	SW5	H26 data	Analog setting current input (Factory default)	C1	0	PTC thermistor input	PTC/NTC	1 (alarm) or 2 (warning)	NTC thermistor input	PTC/NTC	3							
Function	SW5	H26 data																		
Analog setting current input (Factory default)	C1	0																		
PTC thermistor input	PTC/NTC	1 (alarm) or 2 (warning)																		
NTC thermistor input	PTC/NTC	3																		

Figure 2.20 shows the location of slide switches on the control PCB for the input/output terminal configuration.

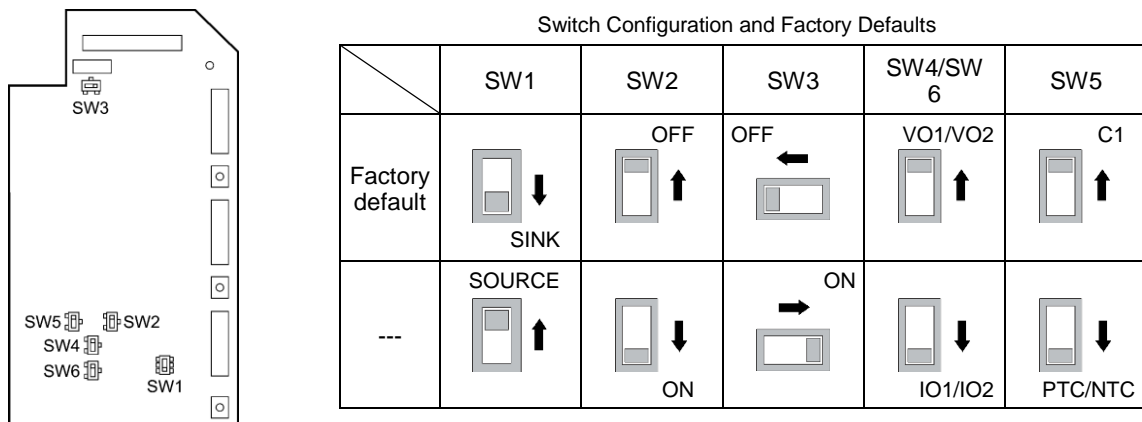

Figure 2.20 Location of the Slide Switches on the Control PCB

Note To move a switch slider, use a tool with a narrow tip (e.g., a tip of tweezers). Be careful not to touch other electronic parts, etc. If the slider is in an ambiguous position, the circuit is unclear whether it is turned ON or OFF and the digital input remains in an undefined state. Be sure to place the slider so that it contacts either side of the switch.

2.4 Mounting and Connecting the Keypad

The standard keypad TP-G1W-J1 meets UL Type 4 (NEMA4) by itself.

■ On the panel or at a remote site

The keypad can be mounted on the panel wall as shown below or installed at a remote site for operation on hand.

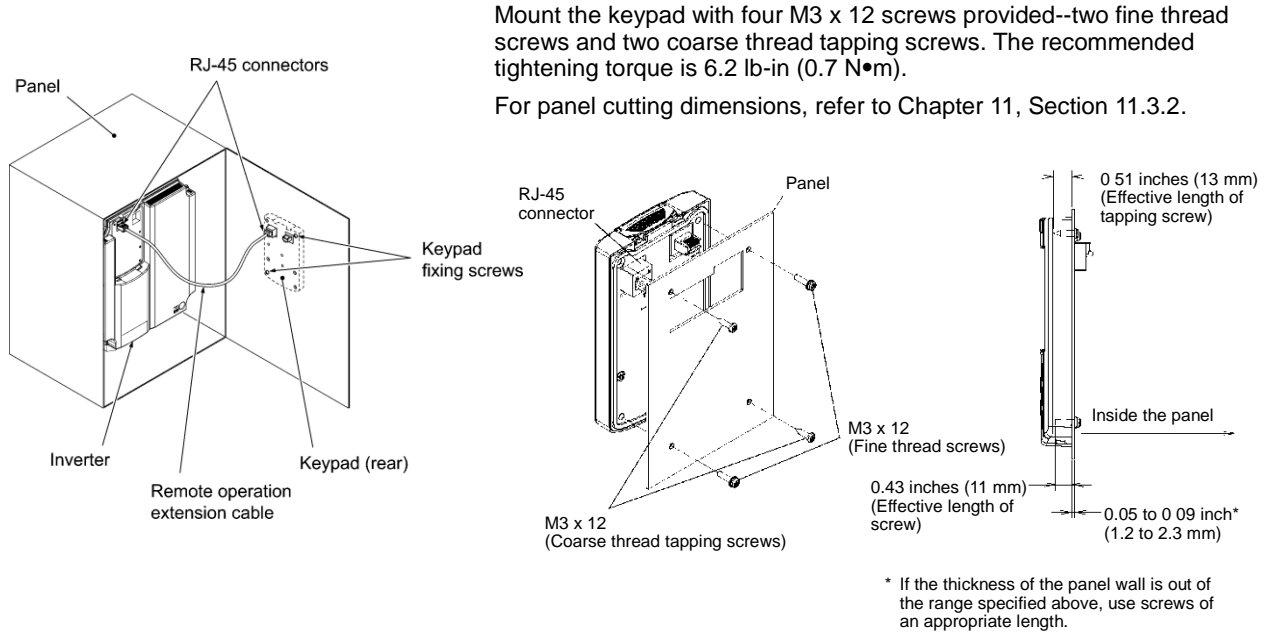

Figure 2.21 Mounting the Keypad on the Panel Wall

To mount the keypad on a place other than an inverter, the parts listed below are needed.

Parts name	Type	Remarks
Extension cable	LAN cable	0BASE-T/100BASE-TX straight type cable compliant with US ANSI/TIA/EIA-568A Category 5. (Less than 66 ft (20 m))

■ On the inverter

To remove the keypad from the inverter, pull it forward while holding down the hook (pointed by the arrow in Figure 2.22). When mounting it, put the keypad back into place in the reverse order of removal.

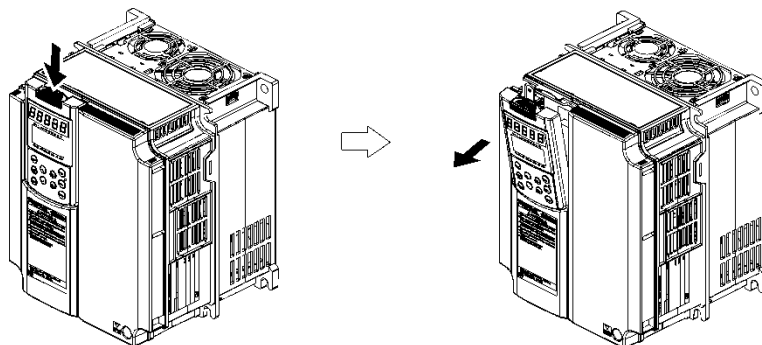

Figure 2.22 Removing the Keypad

2.5 Input Power and Motor Connection

Checking prior to powering on

Fig.2.23 below shows the electrical connections for the input power and motor terminals for various EQ7 DRIVE models. Verify the input power and motor terminals of the model you are installing. **WITH POWER OFF**, make the appropriate connections.

Make sure to follow good wiring practices and all applicable codes. Ensure that the equipment is grounded properly as shown.

DANGER, LETHAL VOLTAGES ARE PRESENT- Before applying power to the EQ7 drive, ensure that the terminal cover is fastened and all wiring connections are secure. After the power has been turned OFF, wait at least ten minutes until the charge indicator extinguishes completely before touching any wiring, circuit boards or components.

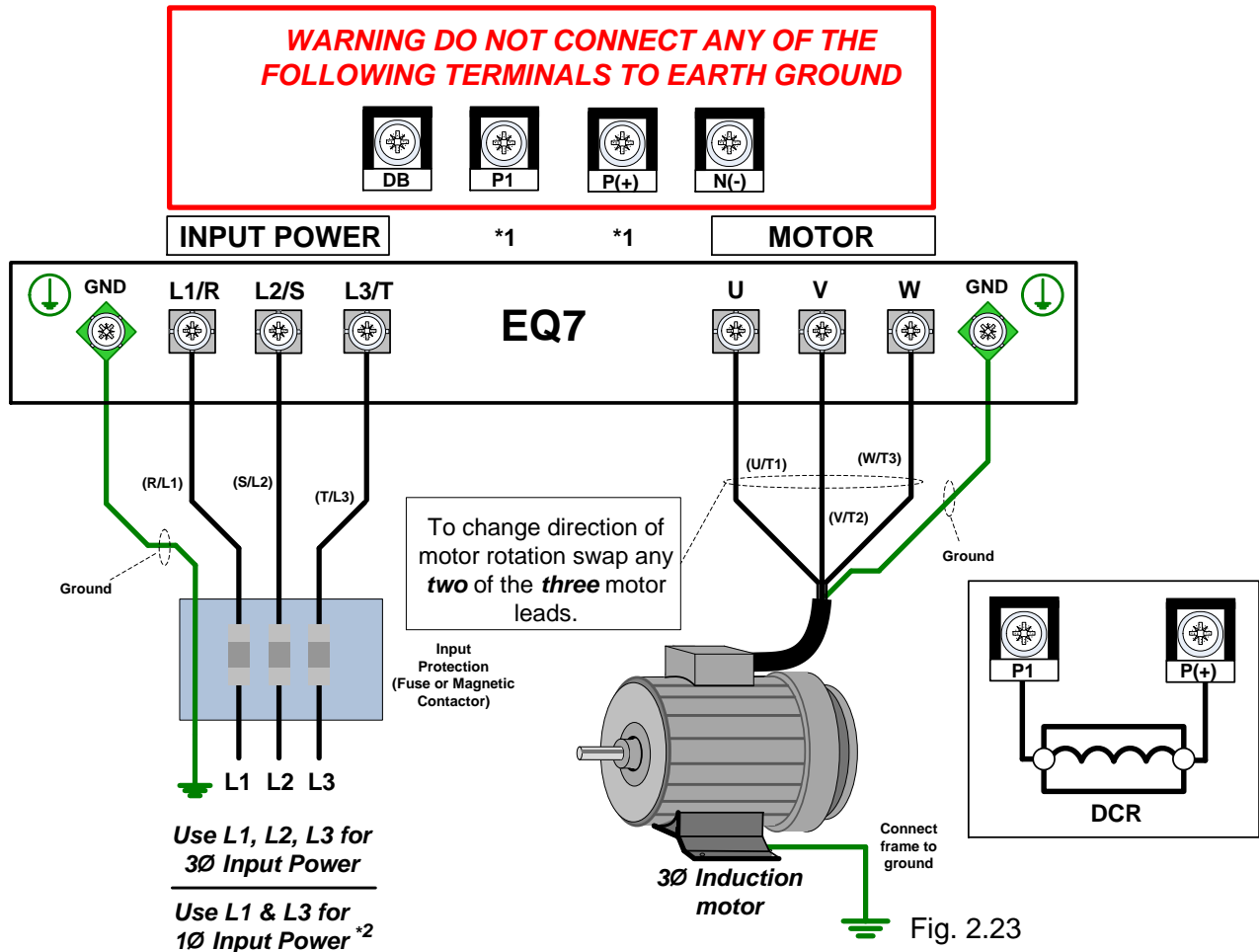

*1. Refer to page 2-11 & 2-12 for connecting a DC reactor from the terminals P1 and P(+).

*2. Make sure the drive is properly sized for single phase input (consult factory).

(Refer to Table 2.6 Recommended Wire Sizes in this manual).

WARNING

- Never connect power supply wires to the EQ7 drive output terminals U, V, and W. Doing so and turning the power ON damages the inverter.
- Be sure to connect the grounding wires of the EQ7 drive and the motor to the ground electrodes. Otherwise, an electric shock could occur.

Check the following before powering on the EQ7 drive.

- 1) Check that the wiring is correct. Especially check the wiring to the EQ7 drive input terminals L1/R, L2/S and L3/T and output terminals U, V, and W. Also check that the grounding wires are connected to the grounding terminals (G) correctly. See Figure 2.23.
- 2) Check the control circuit terminals and main circuit terminals for short circuits or ground faults.
- 3) Check for loose terminals, connectors and screws.
- 4) Check that the motor is separated from mechanical equipment.
- 5) Make sure that all switches of devices connected to the inverter are turned OFF. Powering on the inverter with any of those switches being ON may cause an unexpected motor operation.
- 6) Check that safety measures are taken against runaway of the equipment. Also ensure that all safety guards are in place to prevent human injury.

Chapter 3 Operation using the Keypad

3.1 LED Monitor, LCD Monitor, and Keys

The keypad allows you to start and stop the motor, view various data including maintenance information and alarm information, configure function codes, monitor I/O signal status, copy data, and calculate the load factor.

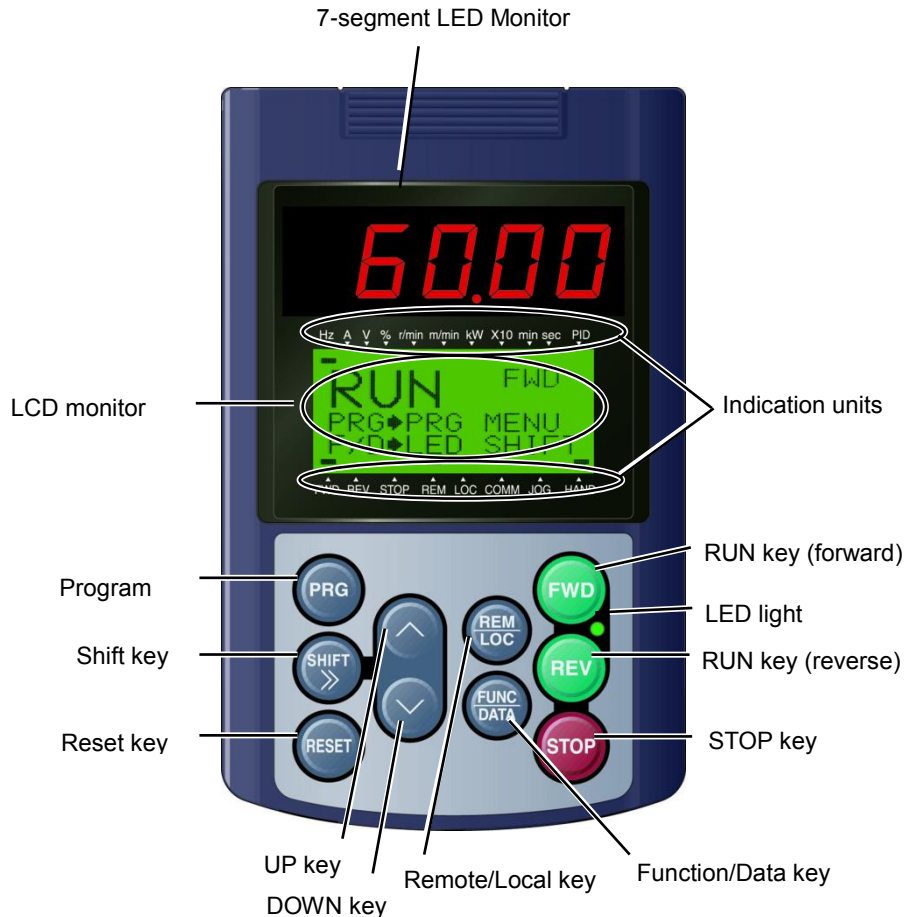

Table 3.1: Overview of Keypad Functions

Item	Monitor	Functions
Monitors		Five-digit, 7-segment LED monitor which displays the following according to the operation modes: <ul style="list-style-type: none"> ■ In Run mode: Running status information (e.g., output frequency, current, and voltage). ■ In Programming mode: Same as above. ■ In Alarm mode: Alarm code, which identifies the alarm when the protective function is activated.
		LCD monitor which displays the following according to the operation modes: <ul style="list-style-type: none"> ■ In Run mode: Running status information. ■ In Programming mode: Menus, function codes and their settings. ■ In Alarm mode: Alarm code, which identifies the alarm when the protective function is activated.
	Indication Units	In Run mode, these show the unit for the number displayed on the 7-segment LED monitor and the running status information on the LCD monitor. For details, see the next page.

Table 3.1 Overview of Keypad Functions (Continued)

Item	Keys	Functions
Programming keys		Switches the operation modes of the inverter.
		Shifts the cursor to the right for entry of a numerical value.
		Pressing this key after removing the cause of an alarm switches the inverter to Running mode. This key is used to reset settings or screen transition.
		UP and DOWN keys, which are used to select the setting items or change the function code data.
		Function/Data key, which switches the operation mode as follows: <ul style="list-style-type: none"> ■ In Run mode: Pressing this key switches the information to be displayed concerning the status of the inverter (output frequency (Hz), output current (A), output voltage (V), etc.). ■ In Programming mode: Pressing this key displays the function code and establishes the newly entered data. ■ In Alarm mode: Pressing this key displays the details of the problem indicated by the alarm code that has come up on the LED monitor.
Operation keys		Starts running the motor in the forward rotation.
		Starts running the motor in the reverse rotation.
		Stops the motor.
		Holding down this key for more than 1 second toggles between local and remote modes.
LED lamp		Lights while a run command is supplied to the inverter.

Details of Indicator Indexes

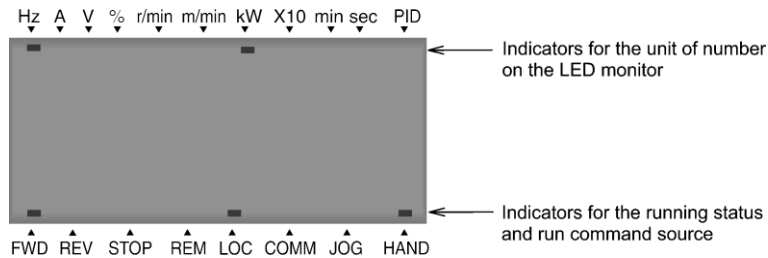

Type	Item	Description (information, condition, and status)
Unit of number on LED monitor	Hz	Output frequency and reference frequency
	A	Output current
	V	Output voltage
	%	Calculated torque, load factor, and speed
	r/min	Preset and actual motor speeds and preset and actual load shaft speeds
	m/min	Preset and actual line speeds
	kW	Input power and motor output
	X10	Data exceeding 99,999
	min	Preset and actual constant feeding rate times
	sec	Timer
	PID	PID process value

Type	Item	Description (information, condition, and status)
Running status	FWD	Running in the forward rotation
	REV	Running in the reverse rotation
	STOP	No output frequency
Run command source	REM	Remote mode
	LOC	Local mode
	COMM	Via communications link (RS-485 (standard, optional), fieldbus option)
	JOG	Jogging mode
	HAND	Via keypad (This item lights also in local mode.)

3.2 Overview of Operation Modes

The EQ7 features the following three operation modes.

Table 3.2 Operation Modes

Mode	Description
Running Mode	This mode allows you to specify run/stop commands in regular operation. It is also possible to monitor the running status in real time. If a light alarm occurs, the <i>L-FL*</i> appears on the LED monitor.
Programming Mode	This mode allows you to configure function code data and check a variety of information relating to the inverter status and maintenance.
Alarm Mode	If an alarm condition arises, the inverter automatically enters the Alarm mode in which you can view the corresponding alarm code* and its related information on the LED and LCD monitors. * Alarm code that represents the cause(s) of the alarm(s) that has been triggered by the protective function. For details, refer to the "Protective Functions" in Chapter 10, Section 10.1.

Figure 3.1 shows the status transition of the inverter between these three operation modes.

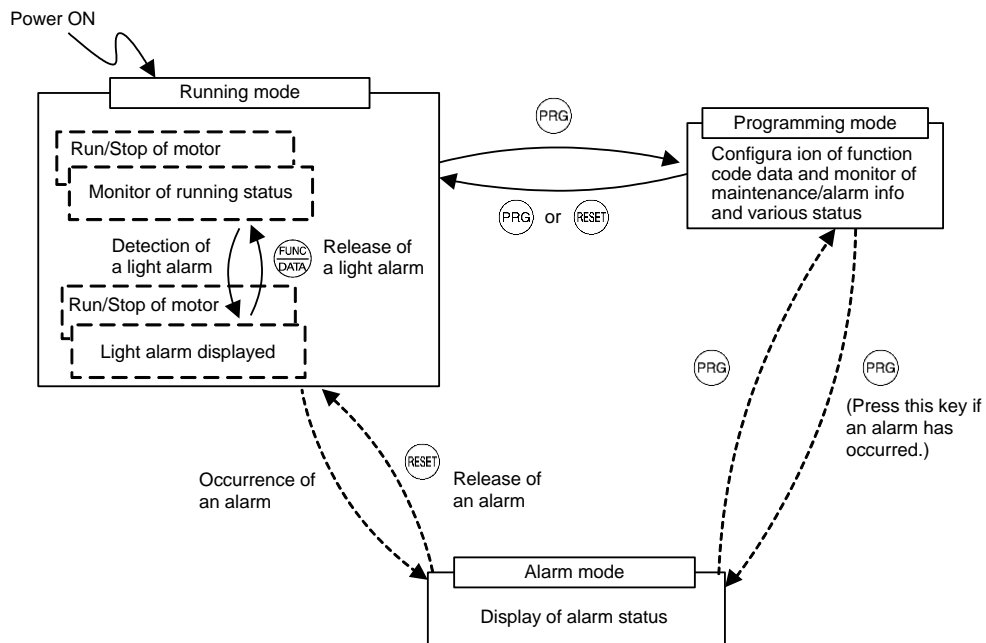



Figure 3.1 Status Transition between Operation Modes

3.3 Running Mode

3.3.1 Running or stopping the motor

By factory default, pressing the **(FWD)** key starts running the motor in the forward direction and pressing the **(STOP)** key decelerates the motor to a stop. The **(REV)** key is disabled. Running or stopping the motor with the keypad is enabled only in Running and Programming modes.

To run the motor in reverse direction or run the motor in reversible mode, change the setting of function code F02.

 For details of function code F02, refer to Chapter 4 "FUNCTION CODES."

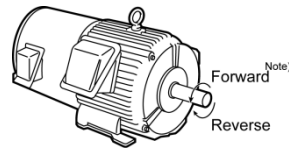

Figure 3.2 Rotational Direction of Motor

Note) The rotational direction of an IEC-compliant motor is opposite to the one shown above.

■ Displaying the running status on the LCD monitor

(1) When function code E45 (LCD monitor item selection) is set at "0"

The LCD monitor displays the running status, the rotational direction, and the operation guide.

(The upper indicators show the unit of values displayed on the LED monitor as detailed in Section 3.3.2. The lower ones show the running status and run command source.)

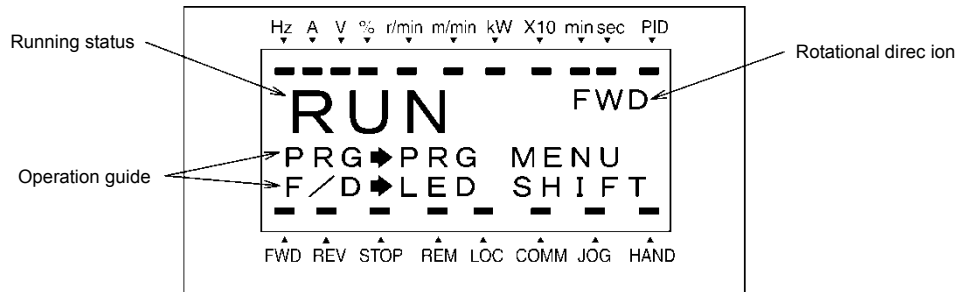

Figure 3.3 Display of Running Status

The running status and the rotational direction are displayed as shown in Table 3.3.

Table 3.3 Running Status and Rotational Direction

Status/Direction	Display	Meaning
Running status	RUN STOP	A run command is given or the inverter is running the motor. A run command is not given and the inverter is stopped.
Rotational direction	FWD REV Blank	Running in the forward rotation Running in the reverse rotation Stopped

(2) When function code E45 (LCD monitor item selection) is set at "1"

The LCD monitor displays the output frequency, output current, and calculated torque in a bar chart.

(The upper indicators show the unit of values displayed on the LED monitor as detailed in Section 3.3.2. The lower ones show the running status and run command source.)

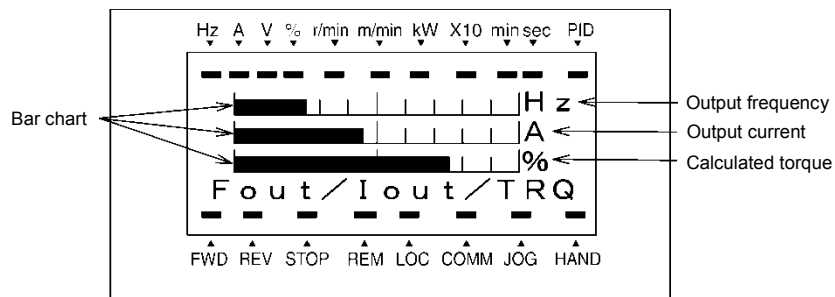

The full scale (maximum value) for each parameter is as follows:

- Output frequency: Maximum frequency
- Output current: 200% of inverter's rated current
- Calculated torque: 200% of rated torque generated by motor

Figure 3.4 Bar Chart

3.3.2 Monitoring the running status on the LED monitor

The items listed below can be monitored on the 7-segment LED monitor. Immediately after the power is turned ON, the monitor item specified by function code E43 is displayed.



Pressing the  key in Running mode switches between monitor items in the sequence shown in Table 3.4. The "Monitor page #" column shows the monitor page of the items supported.

Table 3.4 Items Monitored

Monitored Items on the LED Monitor	Example	Unit	Meaning of Displayed Value	Function code E43	Monitor page #
Speed Monitor	Function code E48 specifies what to be displayed.			0	0
Output frequency 1 (before slip compensation)	5000	Hz	Frequency actually being output (Hz)	(E48 = 0)	
Output frequency 2 (after slip compensation)	5000	Hz	Frequency actually being output (Hz)	(E48 = 1)	
Reference frequency	5000	Hz	Frequency actually being specified (Hz)	(E48 = 2)	
Motor speed	1500	r/min	Output frequency (Hz) x $\frac{120}{P01}$	(E48 = 3)	
Load shaft speed	3000	r/min	Output frequency (Hz) x E50	(E48 = 4)	
Line speed	3000	m/min	Output frequency (Hz) x E50	(E48 = 5)	
Display speed (%)	500	%	$\frac{\text{Output frequency (Hz)}}{\text{Maximum frequency (Hz)}} \times 100$	(E48 = 7)	
Output current	12.34	A	Current output from the inverter in RMS	3	8
Input power	10.25	kW	Input power to the inverter	9	9
Calculated torque	50	%	Motor output torque in % (Calculated value)	8	10
Output voltage	200	V	Voltage output from the inverter in RMS	4	11
Motor output	9.85	kW	Motor output in kW	16	12
Load factor	50	%	Load factor of the motor in % as the rated output being at 100%	15	13

Table 3.4 Items Monitored (Continued)

Monitored Items on the LED Monitor	Example	Unit	Meaning of Displayed Value	Function code E43	Monitor page #
PID command (Note 1)	1000	—	PID command/feedback amount transformed to that of physical value of the object to be controlled (e.g., temperature). Refer to function codes E40 and E41 for details.	10	14
PID feedback amount (Note 1)	900	—		12	15
PID output (Note 1)	1000	%	PID output in % as the maximum frequency being at 100%	14	16
Analog input (Note 2)	8200	—	Analog input to the inverter in a format suitable for a desired scale Refer to function codes E40 and E41 for details.	17	18
Torque current (Note 3)	48	%	Torque current command value or calculated torque current	23	21
Magnetic flux command (Note 3)	50	%	Magnetic flux command value (Available only under vector control)	24	22
Input watt-hour	1000	kWh	$\frac{\text{Input watt-hour (kWh)}}{100}$	25	23

The LCD monitor (given below) shows information related to the item shown on the LED monitor. The monitor items on the LED monitor can be switched by pressing the  key.

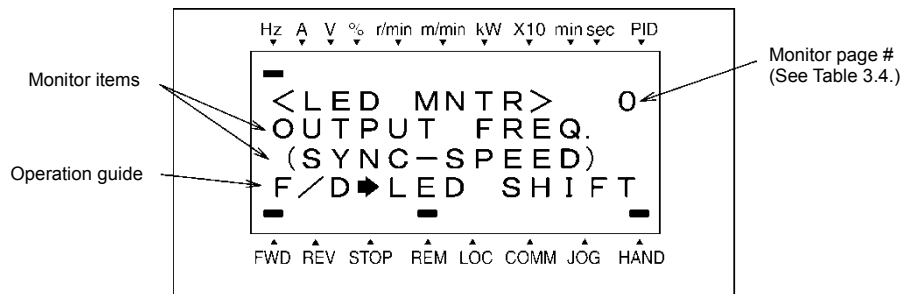

Figure 3.5 LCD Monitor Sample Detailed for the LED Monitor Item

(Note 1) These PID related items appear only under PID control specified by function code J01 (= 1, 2 or 3). When a PID command or PID output is displayed, the dot at the lowest digit on the LED monitor blinks; when a PID feedback amount is displayed, it is lit.

(Note 2) The analog input monitor appears only when the analog input monitor is enabled by any of function codes E61 to E63 (Select terminal function).

(Note 3) Under V/f control, a zero (0) is displayed.

3.3.3 Monitoring light alarms

The EQ7 identifies abnormal states in two categories--Alarm and Light alarm. If the former occurs, the inverter immediately trips; if the latter occurs, the $L-AL$ appears on the LED monitor and the "L-ALARM" appears blinking in the operation guide area on the LCD monitor, but the inverter continues to run without tripping.

Which abnormal states are categorized as a light alarm ("Light alarm" object) should be defined with function codes H81 and H82 beforehand.

Assigning the **LALM** signal to any one of the digital output terminals with any of function codes E20 to E24 and E27 (data = 98) enables the inverter to output the **LALM** signal on that terminal upon occurrence of a light alarm.

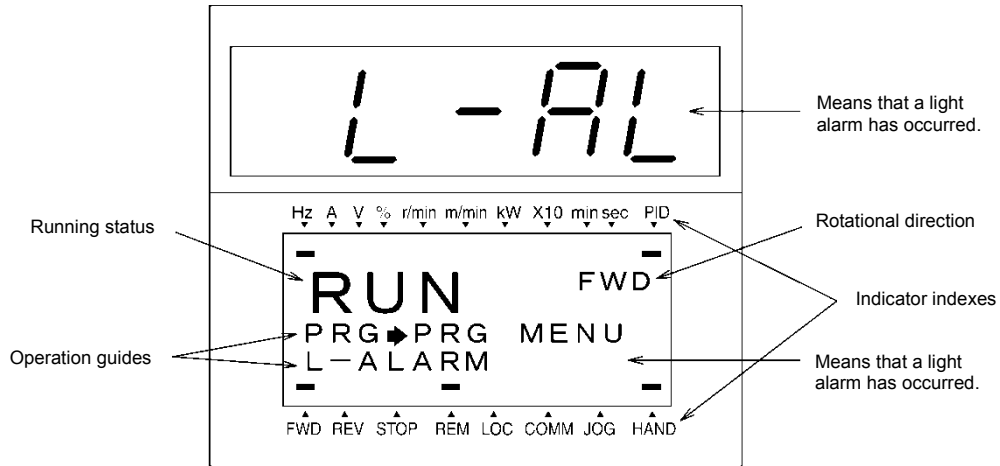

Figure 3.6 Display of Light Alarm

For details of the light alarms, refer to Chapter 10 "TROUBLESHOOTING."

■ How to check a light alarm

If a light alarm occurs, the $L-AL$ appears on the LED monitor. To check the current light alarm, enter Programming mode by pressing the PRG key and select LALM1 on Menu #5 "Maintenance Information."

It is also possible to check the last three light alarms by selecting LALM2 (last) to LALM4 (3rd last).

For details of the menu transition of the maintenance information, refer to Section 3.4.6 "Reading maintenance information."

■ How to remove the current light alarm

After checking the current light alarm, to switch the LED monitor from the $L-AL$ indication back to the running status display (e.g., output frequency), press the PRG key in Running mode.

If the light alarm has been removed, the "L-ALARM" disappears and the **LALM** output signal turns OFF. If not (e.g. DC fan lock), the $L-AL$ on the LED monitor disappears so that normal monitoring becomes available, but the "L-ALARM" remains displayed on the LCD monitor (as shown below) and the **LALM** output signal remains ON.

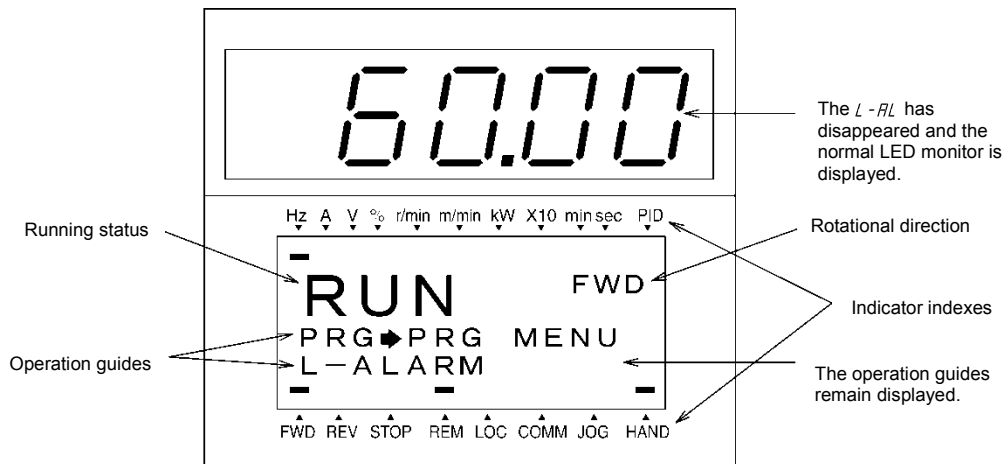

3.4 Programming Mode

Programming mode provides you with these functions--setting and checking function code data, monitoring maintenance information and checking input/output (I/O) signal status. These functions can be easily selected with a menu-driven system. Table 3.5 lists menus available in Programming mode.

When the inverter enters Programming mode from the second time on, the menu selected last in Programming mode will be displayed.

Table 3.5 Menus Available in Programming Mode

Menu #	Menu	Used to:	User Manual Section:
0	Quick Setup	Display only basic function codes previously selected.	3.4.1
1	Data Setting	Display and change the data of the function code selected. (Note)	3.4.2
2	Data Checking	Display the function code selected and its data on the same screen. Also this menu is used to change the function code data or check whether the data has been changed from the factory default.	3.4.3
3	Drive Monitoring	Display the running information required for maintenance or test running.	3.4.4
4	I/O Checking	Display external interface information.	3.4.5
5	Maintenance Information	Display maintenance information including cumulative run time.	3.4.6
6	Alarm Information	Display the recent four alarm codes. Also this menu is used to view the information on the running status at the time the alarm occurred.	3.4.7
7	Alarm Cause	Display the cause of the alarm.	3.4.8
8	Data Copying	Read or write function code data, as well as verifying it.	3.4.9
9	Load Factor Measurement	Measure the maximum output current, average output current, and average braking power.	3.4.10
10	User Setting	Add or delete function codes covered by Quick Setup.	3.4.11
11	Communication Debugging	Confirm the data of function codes exclusively designed for communication (S, M, W, X, and Z codes).	3.4.12

Figure 3.7 shows the transitions between menus in Programming mode.

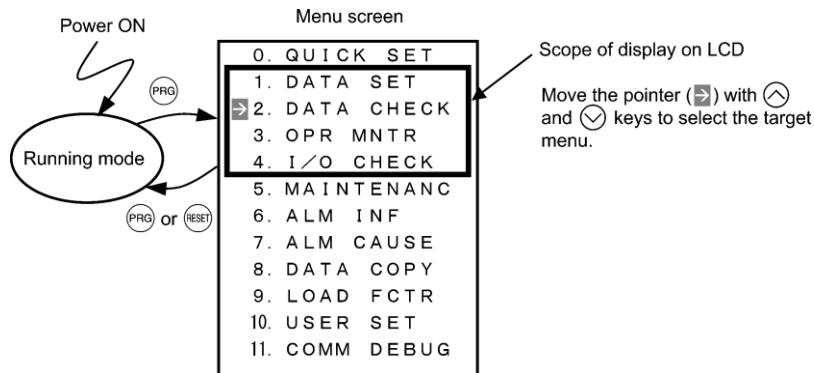

Figure 3.7 Menu Transition in Programming Mode

If no key is pressed for approx. 5 minutes, the inverter automatically goes back to Running mode and turns the backlight OFF.

3.4.1 Setting up function codes quickly using Quick Setup -- Menu #0 "Quick Setup" --

Menu #0 "Quick Setup" in Programming mode quickly displays and sets up a basic set of function codes specified beforehand.

Using Menu #10 "User Setting" adds or deletes function codes to/from the set of function codes registered for Quick Setup by default. The set of function codes registered for Quick Setup is held in the inverter memory (not the keypad). If the keypad on a particular inverter is mounted on any other inverter, therefore, the set of function codes held in the latter inverter is subject to Quick Setup.

The set of function codes subject to Quick Setup can be copied with the copy function (Menu #8 "Data Copying").

Performing data initialization (function code H03) resets the set of function codes subject to Quick Setup to the factory default.

 For the list of function codes subject to Quick Setup by factory default, refer to Chapter 4 "FUNCTION CODES."

The menu transition in Menu #0 is just like that in Menu #1 "Data Setting" given in the next section.

Basic key operation

Same as the basic key operation for Menu #1 "Data Setting."

3.4.2 Setting up function codes -- Menu #1 "Data Setting" --



Menu #1 "Data Setting" in Programming mode allows you to set up all function codes for making the inverter functions match your needs.

Table 3.6 Function Code List

Function Code Group	Function	Description
F codes	Fundamental functions	Functions concerning basic motor running
E codes	Extension terminal functions	Functions concerning the assignment of control circuit terminals Functions concerning the display of the LED monitor
C codes	Control functions	Functions associated with frequency settings
P codes	Motor 1 parameters	Functions for setting up characteristics parameters (such as capacity) of the 1st motor
H codes	High performance functions	Highly added-value functions Functions for sophisticated control
A codes	Motor 2 parameters	Functions for setting up characteristics parameters (such as capacity) of the 2nd motor
J codes	Application functions 1	Functions for applications such as PID control
d codes	Application functions 2	Functions for applications such as speed control
y codes	Link functions	Functions for controlling communication
o codes	Option functions	Functions for options (Note)

(Note) The o codes are displayed only when the corresponding option is mounted on the inverter. For details, refer to the instruction manual of the corresponding option.

■ Function codes requiring simultaneous keying

To modify the data of function code F00 (data protection), H03 (data initialization), or H97 (clear alarm data), simultaneous keying of "STOP +  keys" or "STOP +  keys" is required.

■ Changing, validating, and saving function code data when the inverter is running

Some function codes can be modified when the inverter is running. The modification may or may not take effect immediately. For details, refer to the "Change when running" column in Chapter 5, Section 5.1 "Function Code Tables."

Basic configuration of screens

Figure 3.8 shows the LCD screen transition for Menu #1 "Data Setting."

A hierarchy exists among those screens that are shifted in the order of "menu screen," "list of function codes," and "function code data modification screens."

On the modification screen of the target function code, you can modify or check its data.

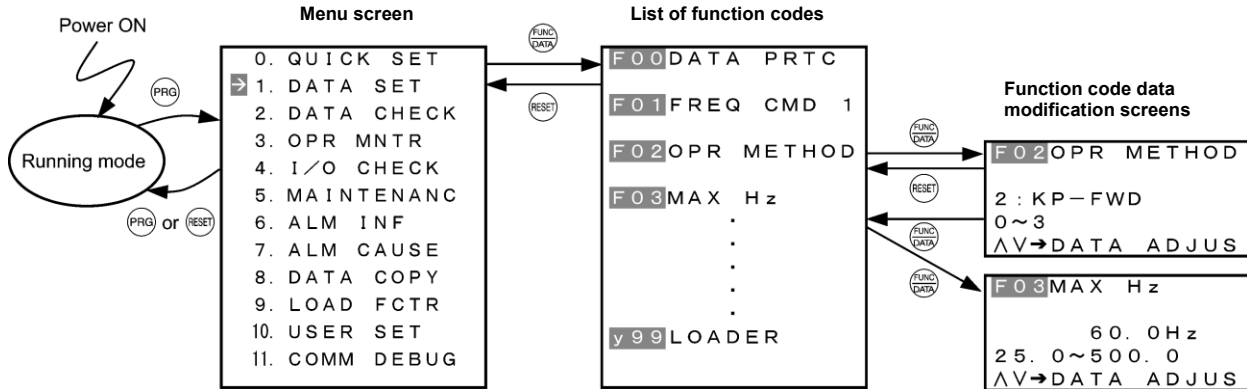
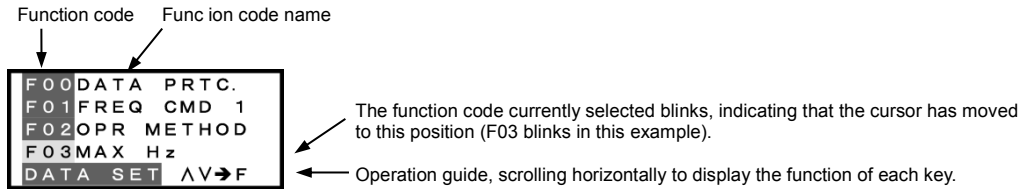

Figure 3.8 Configuration of Screens for "DATA SET"

Screen samples for changing function code data

The "list of function codes" shows function codes, their names, and operation guides.



The "function code data modification screen" shows the function code, its name, its data (before and after change), allowable entry range, and operation guides.

<Before change>

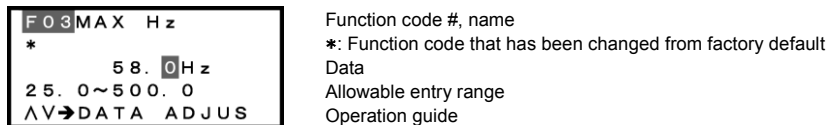

<Changing data>

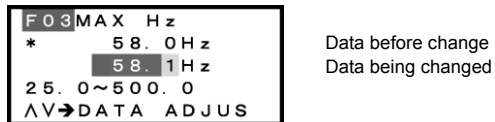
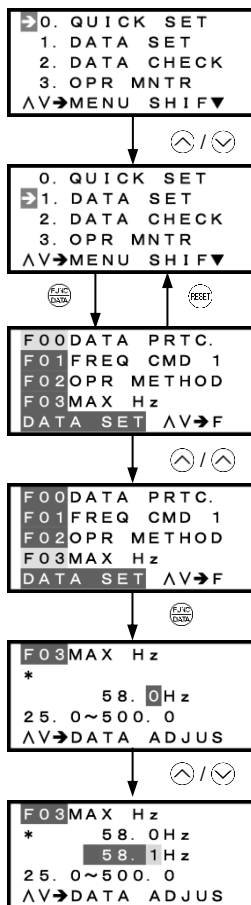

Figure 3.9 Screen Samples for Changing Function Code Data

Basic key operation

This section gives a description of the basic key operation, following the example of the data changing flow shown below. This example shows how to change F03 data (maximum frequency) from 58.0 Hz to 58.1 Hz.

- (1) Turn the inverter ON. It automatically enters Running mode. In that mode, press the key to switch to Programming mode and display the menu screen.
- (2) Move the pointer → to "1. DATA SET" with the and keys, then press the key to proceed to a list of function codes.
- (3) Select the desired function code (F03 in this example) with the and keys, then press the key to display the corresponding function code data screen.
- (4) Change the function code data with the and keys.
Pressing the key causes the blinking digit place to shift (cursor shifting) (The blinking digit can be changed).
- (5) Press the key to establish the function code data.
The data will be saved in the inverter's memory. The display returns to a list of function codes and the cursor moves to the next function code (F04 in this example).
Pressing the key instead of the key cancels the new function code data, reverts to the previous data, returns to a list of function codes, and returns the cursor to the previous function code (F03 in this example).
- (6) Press the key to go back to the menu screen.



(1) To display this menu screen, press key in Running mode to switch to Programming mode.

(2) Move the pointer → to "1. DATA SET" with and keys.

Press key to establish the selected menu and proceed to a list of function codes.

((6) To go back to the menu screen, press key.)

(3) Move the cursor with and keys to select the desired function code.

Press key to establish the selected function code and display its data screen.

(4) Change the function code data with and keys.

(5) Press key to establish the function code data.
To cancel change of data, press key.

Figure 3.10 Screen Transition for "Data Checking"

3.4.3 Checking changed function codes -- Menu #2 "Data Checking" --

Menu #2 "Data Checking" in Programming mode allows you to check function codes and their data that has been changed. The function codes whose data has been changed from the factory defaults are marked with an asterisk (*). Select a function code and press the  key to view or change its data.

The LCD screen transition from Menu #2 is the same as that from Menu #1 "Data Setting," except a list of function codes as shown below.

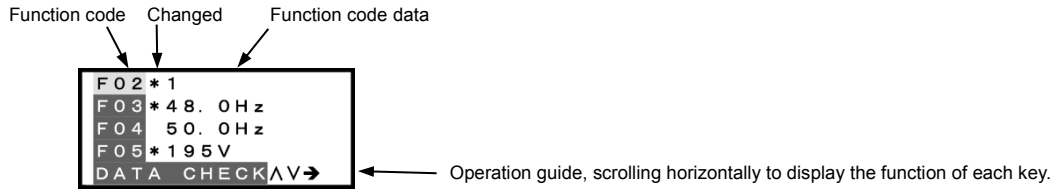

Figure 3.11 List of Function Codes

Basic key operation

Same as the basic key operation for Menu #1 "Data Setting."

3.4.4 Monitoring the running status -- Menu #3 "Drive Monitoring" --

Menu #3 "Drive Monitoring" in Programming mode allows you to monitor the running status during maintenance and test running.

Table 3.7 Drive Monitoring Items

Page # in operation guide	Item	Symbol	Description
1	Output frequency	Fot1	Output frequency (before slip compensation)
	Output frequency	Fot2	Output frequency (after slip compensation)
	Output current	Iout	Output current
	Output voltage	Vout	Output voltage
2	Calculated torque	TRQ	Calculated output torque generated by motor
	Reference frequency	Fref	Frequency specified by a frequency command
	Running direction	FWD REV (Blank)	Forward Reverse Stopped
	Current limit	IL	Current limiting
	Undervoltage Voltage limit	LU VL	Undervoltage detected Voltage limiting
	Torque limit	TL	Torque limiting
	Speed limit	SL	Speed limiting
	Motor selected	M1-M4	Motor 1 to 4
3	Drive control	VF DTV VF-SC VF-PG VC-SL VC-PG	V/f control without slip compensation Dynamic torque vector control V/f control with slip compensation Dynamic torque vector control with speed sensor Vector control without speed sensor Vector control with speed sensor
	Motor speed	SYN	$(\text{Output frequency Hz}) \times \frac{120}{P01}$
	Load shaft speed	LOD	Output frequency (Hz) \times Function code E50
	Line speed	LIN	Output frequency (Hz) \times Function code E50
	Constant peripheral speed control monitor	LSC	Actual peripheral speed under constant peripheral speed control

Table 3.7 Drive Monitoring Items (Continued)

Page # in operation guide	Item	Symbol	Description
4	PID command value	SV	The PID command value and PID feedback amount are displayed after conversion to the virtual physical values (e.g., temperature or pressure) of the object to be controlled using function code E40 and E41 data (PID display coefficients A and B). Display value = (PID command value or feedback amount) × (Coefficient A - B) + B
	PID feedback amount	PV	
	PID output value	MV	PID output value, displayed in % (assuming the maximum frequency (F03) as 100%).
5	Torque limit value A	TLA	Driving torque limit value A (based on motor rated torque)
	Torque limit value B	TLB	Driving torque limit value B (based on motor rated torque)
	Reference torque bias	TRQB	Reserved.
6	Current position pulse	P	Current position pulse for positioning control
	Stop position target pulse	E	Stop position target pulse for positioning control
	Position deviation pulse	dP	Position deviation pulse for positioning control
	Positioning control status	MODE	Positioning control status
7	Motor temperature	NTC	Temperature detected by the NTC thermistor built in the motor
	Ratio setting	Rati	When this setting is 100%, the LED monitor shows 1.00 time of the value to be displayed.
	Magnetic flux command value	FLUX	Flux command value in %.
	Deviation in SY synchronous operation	SY-d	Deviation in SY synchronous operation
8	Current position pulse, 4-multiplied	P4	Current position pulse for positioning control
	Stop position target pulse, 4-multiplied	E4	Stop position target pulse for positioning control
	Position deviation pulse, 4-multiplied	dP4	Position deviation pulse for positioning control
	Positioning control status	MODE	Reserved.

Basic key operation











- (1) Turn the inverter ON. It automatically enters Running mode. In that mode, press the  key to switch to Programming mode and display the menu screen.
- (2) Move the pointer → to "3. OPR MNTR" with the  and  keys.
- (3) Press the  key to establish the selected menu and proceed to a list of monitoring items (consisting of several pages).
- (4) Use the  and  keys to select the page on which the desired monitoring item is shown, then check the running status information of that item.
- (5) Press the  key to go back to the menu screen.

Figure 3.12 shows an example of the LCD screen transition starting from Menu #3 "Drive Monitoring."

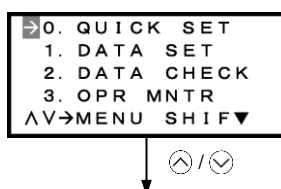

(1) To display this menu screen, press  key in Running mode to switch to Programming mode.

(2) Move the pointer → to "3. OPR MNTR" with  and  keys.

Select desired menu by moving the pointer → with  /  key.

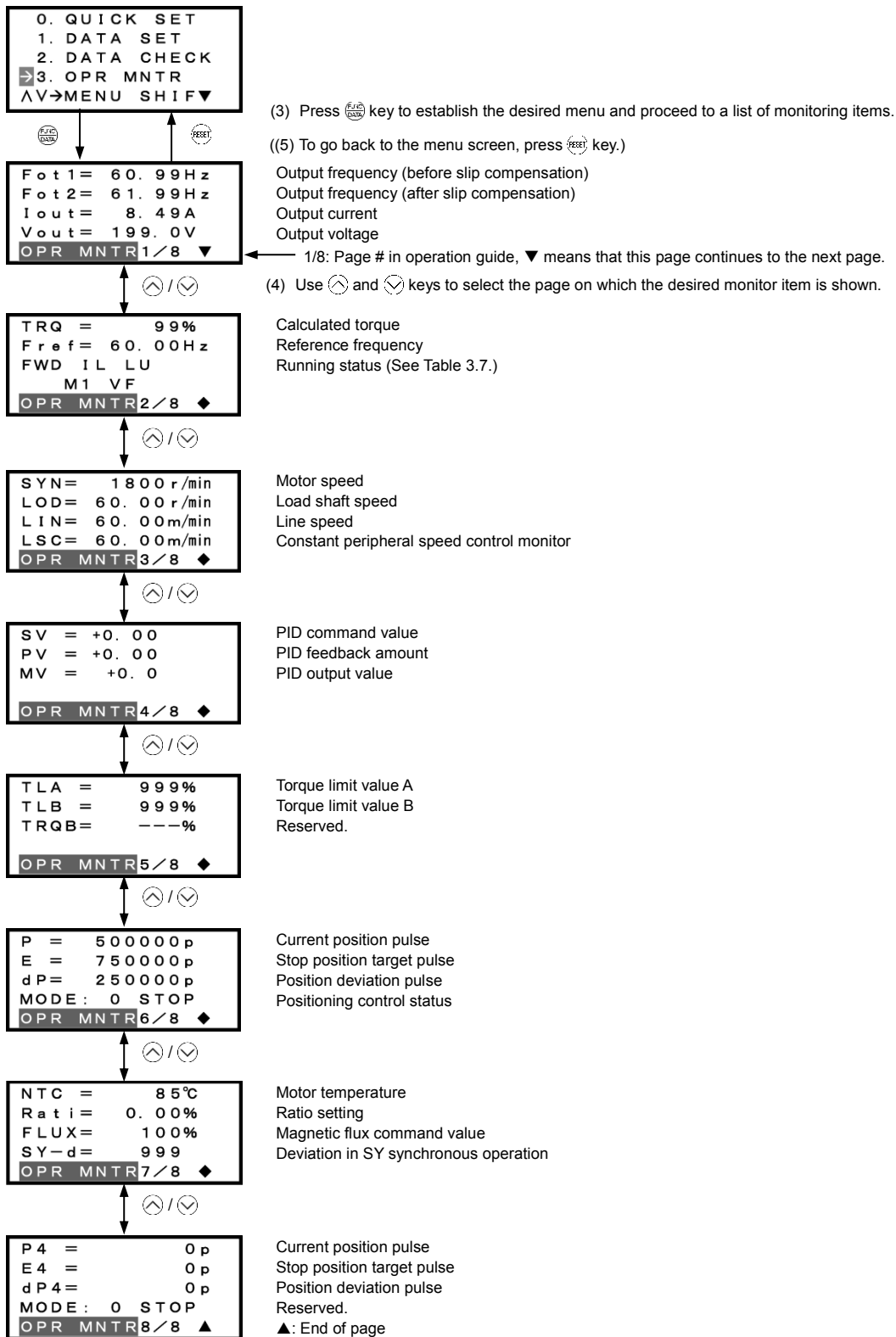

Common operation items

To access the target data, switch to the desired page using the **←** and **→** keys.

▼: This page continues to the next page.

◆: This page is continued from the previous page and continues to the next page.

▲: This page is continued from the previous page.

Figure 3.12 Screen Transition for "Drive Monitoring"

3.4.5 Checking I/O signal status -- Menu #4 "I/O Checking" --

Menu #4 "I/O Checking" in Programming mode allows you to check the I/O states of digital and analog signals. It is used to check the running status during maintenance or test running.

Table 3.8 I/O Check Items

Page # in operation guide	Item	Symbol	Description
1	Input signals on the control circuit terminals	FWD, REV, X1 - X7, EN	ON/OFF state of input signals on the control circuit terminal block. (Highlighted when short-circuited; normal when open)
2	Input signals via communications link	FWD, REV, X1 - X7, XF, XR, RST	Input information for function code S06 (communication) (Highlighted when 1; normal when 0)
3	Output signals	Y1 - Y4, Y5, 30ABC	Output signal information
4	I/O signals (hexadecimal)	Di	Input signals on the control circuit terminal block (in hexadecimal)
		Do	Output signals (in hexadecimal)
		LNK	Input signal entered via communications link (in hexadecimal)
5	Analog input signals	12	Input voltage on terminal [12]
		C1	Input current on terminal [C1]
		V2	Input voltage on terminal [V2]
6	Analog output signals	FM1 FM1 FM2 FM2	Output voltage on terminal [FM1] * Output current on terminal [FM1] Output voltage on terminal [FM2] Output current on terminal [FM2]
7	Input signals on the digital input interface card (option)	Di-o	Input signals on the option card in hexadecimal
	Output signals on the digital output interface card (option)	Do-o	Output signals on the option card in hexadecimal
	Pulse train input	X7	Pulse count signals of pulse train input on terminal [X7]
8	PG pulse rate	P1	Pulse rate (p/s) of the A/B phase signal fed back from the reference PG
		Z1	Pulse rate (p/s) of the Z phase signal fed back from the reference PG
		P2	Pulse rate (p/s) of the A/B phase signal fed back from the slave PG
		Z2	Pulse rate (p/s) of the Z phase signal fed back from the slave PG
9	I/O signals of analog input/output interface card (option)	32	Input voltage on terminal [32] (option)
		C2	Input current on terminal [C2] (option)
		A0	Output voltage on terminal [A0] (option)
		CS	Output current on terminal [CS] (option)

* Some screens differ depending upon the specifications even on the same inverter models.

Basic key operation

- (1) Turn the inverter ON. It automatically enters Running mode. In that mode, press the **(PRG)** key to switch to Programming mode and display the menu screen.
- (2) Move the pointer \rightarrow to "4. I/O CHECK" with the **(\uparrow)** and **(\downarrow)** keys.
- (3) Press the **(FWD)** key to establish the selected menu and proceed to a list of I/O check items (consisting of several pages).
- (4) Use the **(\uparrow)** and **(\downarrow)** keys to select the page on which the desired item is shown, then check the running status information of that item.
- (5) Press the **(RESET)** key to go back to the menu screen.

Figure 3.13 shows an example of the LCD screen transition starting from Menu #4 "I/O Checking."

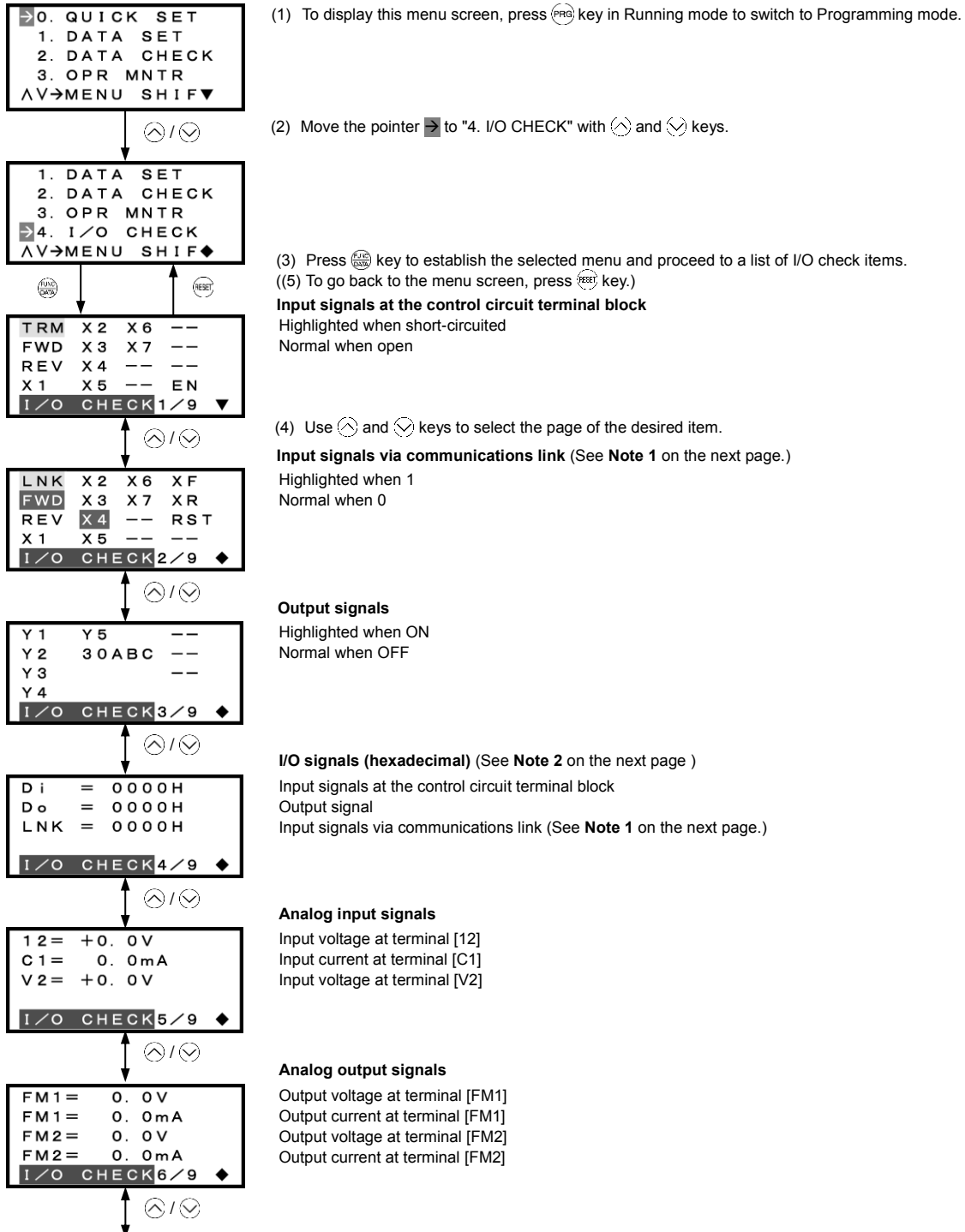

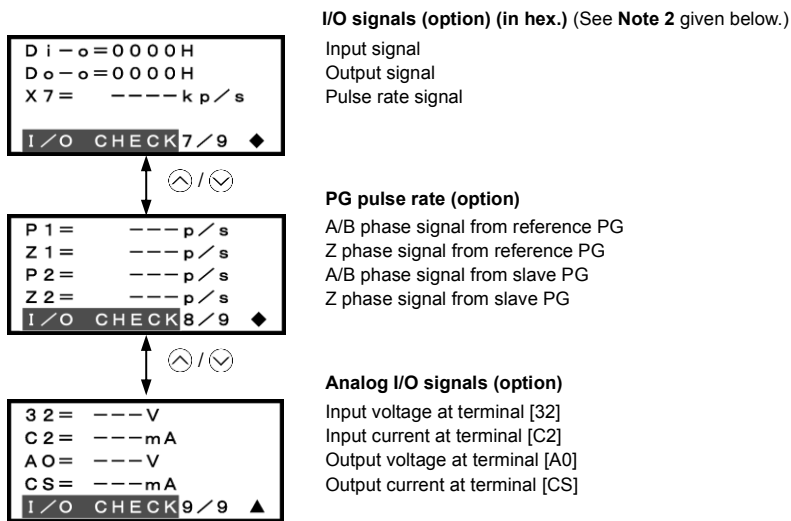

Common operation items

To access the target data, switch to the desired page using the and keys.

- ▼: This page continues to the next page.
- ◆: This page is continued from the previous page and continues to the next page.
- ▲: This page is continued from the previous page.

Figure 3.13 Screen Transition for "I/O Checking"

Note: "----"shown on the display indicates an option card that is not installed.

Chapter 4 Function Codes / Parameters

 Refer to the user manual for function code descriptions not covered in this section.

4.1 Function Code Tables

Function codes enable the EQ7 series of inverters to be set up to match your system requirements.









Each function code consists of a 3-letter alphanumeric string. The first letter is an alphabet that identifies its group and the following two letters are numerals that identify each individual code in the group. The function codes are classified into 13 groups: Fundamental Functions (F codes), Extension Terminal Functions (E codes), Control Functions (C codes), Motor 1 Parameters (P codes), High Performance Functions (H codes), Motor 2 (A codes), Application Functions 1 and 2 (J and d), Link Functions (y codes) and Option Functions (o codes). To determine the property of each function code, set data to the function code.

This manual does not contain the descriptions of Option Function (o codes). For Option Function (o codes), refer to the instruction manual for each option.

The following descriptions supplement those given in the function code tables on the following pages.

■ Changing, validating, and saving function code data when the inverter is running

Function codes are indicated by the following based on whether they can be changed or not when the inverter is running:

Notation	Change when running	Validating and saving function code data
Y*	Possible	If the data of the codes marked with Y* is changed with  and  keys, the change will immediately take effect; however, the change is not saved into the inverter's memory. To save the change, press the  key. If you press the  key without pressing the  key to exit the current state, then the changed data will be discarded and the previous data will take effect for the inverter operation.
Y	Possible	Even if the data of the codes marked with Y is changed with  and  keys, the change will not take effect. Pressing the  key will make the change take effect and save it into the inverter's memory.
N	Impossible	—

■ Copying data

The keypad is capable of copying of the function code data stored in the inverter's memory into the keypad's memory (refer to Menu #7 "Data copying" in Programming mode). With this feature, you can easily transfer the data saved in a source inverter to other destination inverters.

If the specifications of the source and destination inverters differ, some code data may not be copied to ensure safe operation of your power system. Whether data will be copied or not is detailed with the following symbols in the "Data copying" column of the function code tables given on the following pages.

Y: Will be copied unconditionally.

Y1: Will not be copied if the rated capacity differs from the source inverter.

Y2: Will not be copied if the rated input voltage differs from the source inverter.

N: Will not be copied. (The function code marked with "N" is not subject to the Verify operation, either.)

For details of copying operation, refer to the User Manual Chapter 3, Section 3.4.9.

■ Using negative logic for programmable I/O terminals

The negative logic signaling system can be used for the programmable, digital input and output terminals by setting the function code data specifying the properties for those terminals. Negative logic refers to the inverted ON/OFF (logical value 1 (true)/0 (false)) state of input or output signal. An active-ON signal (the function takes effect if the terminal is short-circuited.) in the normal logic system is functionally equivalent to active-OFF signal (the function takes effect if the terminal is opened.) in the negative logic system. Active-ON signals can be switched to active-OFF signals, and vice versa, with the function code data setting, except some signals.

To set the negative logic system for an input or output terminal, enter data of 1000s (by adding 1000 to the data for the normal logic) in the corresponding function code.

Example: "Coast to a stop" command **BX** assigned to any of digital input terminals [X1] to [X7] using any of function codes E01 through E07

Function code data	Description
7	Turning BX ON causes the motor to coast to a stop. (Active-ON)
1007	Turning BX OFF causes the motor to coast to a stop. (Active-OFF)

■ **Drive control**

The EQ7 runs under any of the following drive controls. Some function codes apply exclusively to the specific drive control, which is indicated by letters Y (Applicable) and N (Not applicable) in the "Drive control" column in the function code tables given on the following pages.

Abbreviation in "Drive control" column in function code tables	Control target (H18)	Drive control (F42)
V/f	Speed (Frequency for V/f)	V/f control Dynamic torque control
w/o PG		Vector control without speed sensor
w/ PG		Vector control with speed sensor
Torque control	Torque	Vector control with/without speed sensor

For details about the drive control, refer to "Function code F42 (Drive Control Selection 1)."

 **Note** The EQ7 is a general-purpose inverter whose operation is customized by frequency-basis function codes, like conventional inverters. Under the speed-basis drive control, however, the control target is a motor speed, not a frequency, so convert the frequency to the motor speed according to the following expression.
 Motor speed (r/min) = 120 × Frequency (Hz) ÷ Number of poles

F codes: Fundamental Functions

Code	Name	Data setting range	Change when running	Data copying	Default setting	Drive control			Refer to Page	
						V/f	Vector Control	w/ PG		Torque control
							w/o PG			
F00	Data Protection	0: Disable both data protection and digital reference protection 1: Enable data protection and disable digital reference protection 2: Disable data protection and enable digital reference protection 3: Enable both data protection and digital reference protection	Y	Y	0	Y	Y	Y	Y	4-26
F01	Frequency Command 1	0: ⏪ / ⏩ keys on keypad 1: Voltage input to terminal [12] (-10 to +10 VDC) 2: Current input to terminal [C1] (4 to 20 mA DC) 3: Sum of voltage and current inputs to terminals [12] and [C1] 5: Voltage input to terminal [V2] (-10 to +10 VDC) 7: Terminal command UP/DOWN control 8: ⏪ / ⏩ keys on keypad (balanceless-bumpless switching available) 11: Digital input interface card (option) 12: Pulse train input	N	Y	0	Y	Y	Y	N	4-26
F02	Operation Method	0: Keypad 1: Terminal command FWD or REV 2: Keypad (Forward direction) 3: Keypad (Reverse direction)	N	Y	0	Y	Y	Y	Y	4-34
F03	Maximum Frequency 1	25.0 to 500.0 Hz	N	Y	60.0	Y	Y	Y	Y	
F04	Base Frequency 1	25.0 to 500.0 Hz	N	Y	60.0	Y	Y	Y	Y	
F05	Rated Voltage at Base Frequency 1	0: Output a voltage in proportion to input voltage 80 to 240 V: Output an AVR-controlled voltage (for 230 V series) 160 to 500 V: Output an AVR-controlled voltage (for 460 V series)	N	Y2	230 460	Y	Y	Y	Y	
F06	Maximum Output Voltage 1	80 to 240 V: Output an AVR-controlled voltage (for 230 V series) 160 to 500 V: Output an AVR-controlled voltage (for 460 V series)	N	Y2	230 460	Y	N	N	Y	
F07	Acceleration Time 1	0.00 to 6000 s	Y	Y	*1	Y	Y	Y	N	4-37
F08	Deceleration Time 1	Note: Entering 0.00 cancels the acceleration time, requiring external soft-start.	Y	Y	*1	Y	Y	Y	N	
F09	Torque Boost 1	0.0% to 20.0% (percentage with respect to "Rated Voltage at Base Frequency 1")	Y	Y	0.0	Y	N	N	N	4-40 4-56
F10	Electronic Thermal Overload Protection for Motor 1 (Select motor characteristics)	1: For a general-purpose motor with shaft-driven cooling fan 2: For an inverter-driven motor, non-ventilated motor, or motor with separately powered cooling fan	Y	Y	1	Y	Y	Y	Y	4-41
F11	(Overload detection level)	0.00: Disable 1% to 135% of the rated current (allowable continuous drive current) of the motor	Y	Y1 Y2	*2	Y	Y	Y	Y	
F12	(Thermal time constant)	0.5 to 75.0 min	Y	Y	*3	Y	Y	Y	Y	
F14	Restart Mode after Momentary Power Failure (Mode selection)	0: Trip immediately 1: Trip after a recovery from power failure 2: Trip after decelerate-to-stop 3: Continue to run, for heavy inertia or general loads 4: Restart at the frequency at which the power failure occurred, for general loads 5: Restart at the starting frequency	Y	Y	0	Y	Y	Y	N	4-43
F15	Frequency Limiter (High)	0.0 to 500.0 Hz	Y	Y	70.0	Y	Y	Y	N	4-49
F16	Frequency Limiter (Low)	0.0 to 500.0 Hz	Y	Y	0.0	Y	Y	Y	N	4-49
F18	Bias (Frequency command 1)	-100.00% to 100.00%	Y*	Y	0.00	Y	Y	Y	N	4-50 4-26
F20	DC Braking 1 (Braking starting frequency)	0.0 to 60.0 Hz	Y	Y	0.0	Y	Y	Y	N	4-50
F21	(Braking level)	0% to 80% (LD/MD mode) *4, 0% to 100% (HD mode)	Y	Y	0	Y	Y	Y	N	
F22	(Braking time)	0.00 (Disable); 0.01 to 30.00 s	Y	Y	0.00	Y	Y	Y	N	
F23	Starting Frequency 1	0.0 to 60.0 Hz	Y	Y	0.5	Y	Y	Y	N	4-51
F24	(Holding time)	0.00 to 10.00 s	Y	Y	0.00	Y	Y	Y	N	
F25	Stop Frequency	0.0 to 60.0 Hz	Y	Y	0.2	Y	Y	Y	N	

The shaded function codes are applicable to the quick setup.

Y: Applicable / N: Not Applicable.

Code	Name	Data setting range	Change when running	Data copying	Default setting	Drive control			Refer to Page	
						V/f	Vector Control w/o PG	w/ PG		Torque control
F26	Motor Sound(Carrier frequency)	Variable Torque Models 0.5 to 30HP: 0.75 to 16 KHz 40 to 100HP: 0.75 to 10 KHz 125 to 900HP: 0.75 to 6 KHz 1000HP: 0.75 to 4 KHz Constant Torque Models 0.5 to 75HP: 0.75 to 16 KHz 100 to 125HP: 0.75 to 10 KHz 150 to 700HP: 0.75 to 2 KHz 800 to 900HP: 0.75 to 6 KHz CT-V Models 0.5 to 75HP: 0.75 to 16 KHz 100 to 700HP: 0.75 to 10 KHz 800 to 900HP: 0.75 to 6 KHz	Y	Y	2KHz	Y	Y	Y	Y	4-54
F27	Motor Sound (Tone)	0: Level 0 (Inactive) 1: Level 1 2: Level 2 3: Level 3	Y	Y	0	Y	N	N	Y	4-54
F29	Analog Output [FM1] (Mode selection)	0: Output in voltage (0 to 10 VDC) 1: Output in current (4 to 20 mA DC) 2: Output in current (0 to 20 mA DC)	Y	Y	0	Y	Y	Y	Y	
F30	(Voltage adjustment)	0% to 300%	Y*	Y	100	Y	Y	Y	Y	
F31	(Function)	Select a function to be monitored from the followings. 0: Output frequency 1 (before slip compensation) 1: Output frequency 2 (after slip compensation) 2: Output current 3: Output voltage 4: Output torque 5: Load factor 6: Input power 7: PID feedback amount (PV) 8: PG feedback value 9: DC link bus voltage 10: Universal AO 13: Motor output 14: Calibration (+) 15: PID command (SV) 16: PID output (MV)	Y	Y	0	Y	Y	Y	Y	
		17: Positional deviation in synchronous run mode				N	N	Y	N	
F32	Analog Output [FM2] (Mode selection)	0: Output in voltage (0 to 10 VDC) 1: Output in current (4 to 20 mA DC) 2: Output in current (0 to 20 mA DC)	Y	Y	0	Y	Y	Y	Y	
F34	(Voltage adjustment)	0% to 300%	Y*	Y	100	Y	Y	Y	Y	
F35	(Function)	Select a function to be monitored from the followings. 0: Output frequency 1 (before slip compensation) 1: Output frequency 2 (after slip compensation) 2: Output current 3: Output voltage 4: Output torque 5: Load factor 6: Input power 7: PID feedback amount (PV) 8: PG feedback value 9: DC link bus voltage 10: Universal AO 13: Motor output 14: Calibration (+) 15: PID command (SV) 16: PID output (MV)	Y	Y	0	Y	Y	Y	Y	
		17: Positional deviation in synchronous run mode				N	N	Y	N	

The shaded function codes are applicable to the quick setup.

Y: Applicable / N: Not Applicable.

Code	Name	Data setting range	Change when running	Data copying	Default setting	Drive control				Refer to Page
						V/f	Vector Control	w/ PG	Torque control	
F37	Load Selection/ Auto Torque Boost/ Auto Energy Saving Operation 1	0: Variable torque load 1: Constant torque load 2: Auto torque boost 3: Auto energy saving (Variable torque load during ACC/DEC) 4: Auto energy saving (Constant torque load during ACC/DEC) 5: Auto energy saving (Auto torque boost during ACC/DEC)	N	Y	1	Y	N	Y	N	4-56
F38	Stop Frequency(Detection mode)	0: Detected speed 1: Reference speed	N	Y	0	N	N	Y	N	4-58
F39	(Holding Time)	0.00 to 10.00 s	Y	Y	0.00	Y	Y	Y	N	
F40	Torque Limiter 1-1	-300% to 300%; 999 (Disable)	Y	Y	999	Y	Y	Y	Y	
F41	1-2	-300% to 300%; 999 (Disable)	Y	Y	999	Y	Y	Y	Y	
F42	Drive Control Selection 1	0: V/f control with slip compensation inactive 1: Dynamic torque control 5: Vector control without speed sensor 6: Vector control with speed sensor	N	Y	0	Y	Y	Y	Y	4-65
F43	Current Limiter (Mode selection)	0: Disable (No current limiter works.) 1: Enable at constant speed (Disable during ACC/DEC) 2: Enable during ACC/constant speed operation	Y	Y	2	Y	N	N	N	4-67
F44	(Level)	20% to 200% (The data is interpreted as the rated output current of the inverter for 100%.)	Y	Y	*5	Y	N	N	N	
F50	Electronic Thermal Overload Protection for Braking Resistor (Discharging capability)	0 (Braking resistor built-in type), 1 to 9000 kW, OFF (Disable)	Y	Y1 Y2	*6	Y	Y	Y	Y	4-68
F51	(Allowable average loss)	0.001 to 99.99 kW	Y	Y1 Y2	0.001	Y	Y	Y	Y	
F52	(Resistance)	0.01 to 999Ω	Y	Y1 Y2	0.01	Y	Y	Y	Y	
F80	Switching between LD, MD and HD drive modes	1: LD (Variable Torque mode) 2: MD (Constant Torque mode) 0: HD (CT-Vector mode)	N	Y	1	Y	Y	Y	Y	4-69

The shaded function codes are applicable to the quick setup.

*1 6.00 s for inverters of 40 HP or below; 20.00 s for those of 50 HP or above

*2 The motor rated current is automatically set. See Table B (P03/A17).

*3 5.0 min for inverters of 40 HP or below; 10.0 min for those of 50 HP or above

*4 0% to 100% for inverters of 7.5 HP or below

*5 160% for inverters of 7.5 HP or below; 130% for those of 10 HP or above

*6 0 for inverters of 15 HP or below; OFF for those of 20 HP or above

The shaded function codes are applicable to the quick setup.

Y: Applicable / N: Not Applicable.

E codes: Extension Terminal Functions

Code	Name	Data setting range	Change when running	Data copying	Default setting	Drive control				Refer to Page
						V/f	Vector Control	w/ PG	Torque control	
							w/o PG			
E01	Terminal [X1] Function	0 (1000): Select multi-frequency (0 to 1 steps) (SS1)	N	Y	0	Y	Y	Y	N	4-71
E02	Terminal [X2] Function	1 (1001): Select multi-frequency (0 to 3 steps) (SS2)	N	Y	1	Y	Y	Y	N	
E03	Terminal [X3] Function	2 (1002): Select multi-frequency (0 to 7 steps) (SS4)	N	Y	2	Y	Y	Y	N	
E04	Terminal [X4] Function	3 (1003): Select multi-frequency (0 to 15 steps) (SS8)	N	Y	3	Y	Y	Y	N	
E05	Terminal [X5] Function	4 (1004): Select ACC/DEC time (2 steps) (RT1)	N	Y	4	Y	Y	Y	N	
E06	Terminal [X6] Function	5 (1005): Select ACC/DEC time (4 steps) (RT2)	N	Y	5	Y	Y	Y	N	
E07	Terminal [X7] Function	6 (1006): Enable 3-wire operation (HLD)	N	Y	8	Y	Y	Y	Y	
		7 (1007): Coast to a stop (BX)				Y	Y	Y	Y	
		8 (1008): Reset alarm (RST)				Y	Y	Y	Y	
		9 (1009): Enable external alarm trip (THR) (9 = Active OFF, 1009 = Active ON)				Y	Y	Y	Y	
		10 (1010): Ready for jogging (JOG)				Y	Y	Y	N	
		11 (1011): Select frequency command 2/1 (Hz2/Hz1)				Y	Y	Y	N	
		12 (1012): Select motor 2 (M2)				Y	Y	Y	Y	
		13: Enable DC braking (DCBRK)				Y	Y	Y	N	
		14 (1014): Select torque limiter level 2/1 (TL2/TL1)				Y	Y	Y	Y	
		15: Switch to commercial power (50 Hz) (SW50)				Y	N	N	N	
		16: Switch to commercial power (60 Hz) (SW60)				Y	N	N	N	
		17 (1017): UP (Increase output frequency) (UP)				Y	Y	Y	N	
		18 (1018): DOWN (Decrease output frequency) (DOWN)				Y	Y	Y	N	
		19 (1019): Enable data change with keypad (WE-KP)				Y	Y	Y	Y	
		20 (1020): Cancel PID control (Hz/PID)				Y	Y	Y	N	
		21 (1021): Switch normal/inverse operation (IVS)				Y	Y	Y	N	
		22 (1022): Interlock (IL)				Y	Y	Y	Y	
		23 (1023): Cancel torque control (Hz/TRQ)				N	N	N	Y	
		24 (1024): Enable communications link via RS-485 or fieldbus (option) (LE)				Y	Y	Y	Y	
		25 (1025): Universal DI (U-DI)				Y	Y	Y	Y	
		26 (1026): Enable auto search for idling motor speed at starting (STM)				Y	Y	N	Y	
		30 (1030): Force to stop (STOP) (30 = Active OFF, 1030 = Active ON)				Y	Y	Y	Y	
		32 (1032): Pre-excitation (EXITE)				N	Y	Y	N	
		33 (1033): Reset PID integral and differential components (PID-RST)				Y	Y	Y	N	
		34 (1034): Hold PID integral component (PID-HLD)				Y	Y	Y	N	
		35 (1035): Select local (keypad) operation (LOC)				Y	Y	Y	Y	
		39: Protect motor from dew condensation (DWP)				Y	Y	Y	Y	
		40: Enable integrated sequence to switch to commercial power (50 Hz) (ISW50)				Y	N	N	N	
		41: Enable integrated sequence to switch to commercial power (60 Hz) (ISW60)				Y	N	N	N	
		47 (1047): Servo-lock command (LOCK)				N	N	Y	N	
		48: Pulse train input (available only on terminal [X7] (E07)) (PIN)				Y	Y	Y	Y	
		49 (1049): Pulse train sign (available on terminals except [X7] (E01 to E06)) (SIGN)				Y	Y	Y	Y	
		59 (1059): Enable battery operation (BATRY)				Y	Y	Y	Y	
		70 (1070): Cancel constant peripheral speed control (Hz/LSC)				Y	Y	Y	N	
		71 (1071): Hold the constant peripheral speed control frequency in the memory (LSC-HLD)				Y	Y	Y	N	
		72 (1072): Count the run time of commercial power-driven motor 1 (CRUN-M1)				Y	N	N	Y	
		73 (1073): Count the run time of commercial power-driven motor 2 (CRUN-M2)				Y	N	N	Y	
		76 (1076): Select droop control (DROOP)				Y	Y	Y	N	
		77 (1077): Cancel PG alarm (PG-CCL)				N	N	Y	Y	
		80 (1080): Cancel customizable logic (CLC)				Y	Y	Y	Y	
		81 (1081): Clear all customizable logic timers (CLTC)				Y	Y	Y	Y	
		100: No function assigned (NONE)				Y	Y	Y	Y	
		Setting the value in parentheses () shown above assigns a negative logic input to a terminal.								

The shaded function codes are applicable to the quick setup.

Y: Applicable / N: Not Applicable.

Code	Name	Data setting range	Change when running	Data copying	Default setting	Drive control				Refer to Page
						V/f	Vector Control w/o PG	w/ PG	Torque control	
E10	Acceleration Time 2	0.00 to 6000 s	Y	Y	*1	Y	Y	Y	N	4-37
E11	Deceleration Time 2	Note: Entering 0.00 cancels the acceleration time, requiring external soft-start and -stop.	Y	Y	*1	Y	Y	Y	N	
E12	Acceleration Time 3		Y	Y	*1	Y	Y	Y	N	
E13	Deceleration Time 3		Y	Y	*1	Y	Y	Y	N	
E14	Acceleration Time 4		Y	Y	*1	Y	Y	Y	N	
E15	Deceleration Time 4		Y	Y	*1	Y	Y	Y	N	
E16	Torque Limiter 2-1		-300% to 300%; 999 (Disable)	Y	Y	999	Y	Y	Y	Y
E17	Torque Limiter 2-2	-300% to 300%; 999 (Disable)	Y	Y	999	Y	Y	Y	Y	
		Selecting function code data assigns the corresponding function to terminals [Y1] to [Y5A/C] and [30A/B/C] as listed below.								4-88
E20	Terminal [Y1] Function	0 (1000): Inverter running (RUN)	N	Y	0	Y	Y	Y	Y	
E21	Terminal [Y2] Function	1 (1001): Frequency (speed) arrival signal (FAR)	N	Y	1	Y	Y	Y	N	
E22	Terminal [Y3] Function	2 (1002): Frequency (speed) detected (FDT)	N	Y	2	Y	Y	Y	Y	
E23	Terminal [Y4] Function	3 (1003): Undervoltage detected (Inverter stopped) (LU)	N	Y	7	Y	Y	Y	Y	
E24	Terminal [Y5A/C] Function	4 (1004): Torque polarity detected (B/D)	N	Y	15	Y	Y	Y	Y	
E27	Terminal [30A/B/C] Function (Relay output)	5 (1005): Inverter output limiting (IOL)	N	Y	99	Y	Y	Y	Y	
		6 (1006): Auto-restarting after momentary power failure (IPF)				Y	Y	Y	Y	
		7 (1007): Motor overload early warning (OL)				Y	Y	Y	Y	
		8 (1008): Keypad operation enabled (KP)				Y	Y	Y	Y	
		10 (1010): Inverter ready to run (RDY)				Y	Y	Y	Y	
		11: Switch motor drive source between commercial power and inverter output (For MC on commercial line) (SW88)				Y	N	N	N	
		12: Switch motor drive source between commercial power and inverter output (For secondary side) (SW52-2)				Y	N	N	N	
		13: Switch motor drive source between commercial power and inverter output (For primary side) (SW52-1)				Y	N	N	N	
		15 (1015): Select AX terminal function (For MC on primary side) (AX)				Y	Y	Y	Y	
		22 (1022): Inverter output limiting with delay (IOL2)				Y	Y	Y	Y	
		25 (1025): Cooling fan in operation (FAN)				Y	Y	Y	Y	
		26 (1026): Auto-resetting (TRY)				Y	Y	Y	Y	
		27 (1027): Universal DO (U-DO)				Y	Y	Y	Y	
		28 (1028): Heat sink overheat early warning (OH)				Y	Y	Y	Y	
		29 (1029): Synchronization completed (SY)				N	N	Y	N	
		30 (1030): Lifetime alarm (LIFE)				Y	Y	Y	Y	
		31 (1031): Frequency (speed) detected 2 (FDT2)				Y	Y	Y	Y	
		33 (1033): Reference loss detected (REF OFF)				Y	Y	Y	Y	
		35 (1035): Inverter output on (RUN2)				Y	Y	Y	Y	
		36 (1036): Overload prevention control (OLP)				Y	Y	Y	N	
		37 (1037): Current detected (ID)				Y	Y	Y	Y	
		38 (1038): Current detected 2 (ID2)				Y	Y	Y	Y	
		39 (1039): Current detected 3 (ID3)				Y	Y	Y	Y	
		41 (1041): Low current detected (IDL)				Y	Y	Y	Y	
		42 (1042): PID alarm (PID-ALM)				Y	Y	Y	N	
		43 (1043): Under PID control (PID-CTL)				Y	Y	Y	N	
		44 (1044): Motor stopped due to slow flowrate under PID control (PID-STP)				Y	Y	Y	N	
		45 (1045): Low output torque detected (U-TL)				Y	Y	Y	Y	
		46 (1046): Torque detected 1 (TD1)				Y	Y	Y	Y	
		47 (1047): Torque detected 2 (TD2)				Y	Y	Y	Y	
		48 (1048): Motor 1 selected (SWM1)				Y	Y	Y	Y	
		49 (1049): Motor 2 selected (SWM2)				Y	Y	Y	Y	
		52 (1052): Running forward (FRUN)				Y	Y	Y	Y	
		53 (1053): Running reverse (RRUN)				Y	Y	Y	Y	
		54 (1054): In remote operation (RMT)				Y	Y	Y	Y	
		56 (1056): Motor overheat detected by thermistor (THM)				Y	Y	Y	Y	
		57 (1057): Brake signal (BRKS)				Y	Y	Y	N	
		58 (1058): Frequency (speed) detected 3 (FDT3)				Y	Y	Y	Y	
		59 (1059): Terminal [C1] wire break (C1OFF)				Y	Y	Y	Y	

*1 6.00 s for inverters of 40 HP or below; 20.00 s for those of 50 HP or above

Item values in parentheses indicated value for negative logic.

Y: Applicable / N: Not Applicable.

Code	Name	Data setting range	Change when running	Data copying	Default setting	Drive control				Refer to Page
						V/f	Vector Control w/o PG	w/ PG	Torque control	
		70 (1070): Speed valid (DNZS) 71 (1071): Speed agreement (DSAG) 72 (1072): Frequency (speed) arrival signal 3 (FAR3) 76 (1076): PG error detected (PG-ERR) 82 (1082): Positioning completion signal (PSET) 84 (1084): Maintenance timer (MNT) 98 (1098): Light alarm (L-ALM) 99 (1099): Alarm output (for any alarm) (ALM) 101 (1101): Enable circuit failure detected (DECF) 102 (1102): Enable input OFF (EN OFF) 105 (1105): Braking transistor broken (DBAL) 111 (1111): Customizable logic output signal 1 (CLO1) 112 (1112): Customizable logic output signal 2 (CLO2) 113 (1113): Customizable logic output signal 3 (CLO3) 114 (1114): Customizable logic output signal 4 (CLO4) 115 (1115): Customizable logic output signal 5 (CLO5) Setting the value in parentheses () shown above assigns a negative logic output to a terminal.				N	Y	Y	Y	4-88
E30	Frequency Arrival (Hysteresis width)	0.0 to 10.0 Hz	Y	Y	2.5	Y	Y	Y	N	4-93
E31	Frequency Detection 1 (Level)	0.0 to 500.0 Hz	Y	Y	60.0	Y	Y	Y	Y	4-94
E32	(Hysteresis width)	0.0 to 500.0 Hz	Y	Y	1.0	Y	Y	Y	Y	
E34	Overload Early Warning/Current Detection (Level)	0.00 (Disable); Current value of 1% to 200% of the inverter rated current	Y	Y1 Y2	*2	Y	Y	Y	Y	4-95
E35	(Timer)	0.01 to 600.00s	Y	Y	10.00	Y	Y	Y	Y	
E36	Frequency Detection 2 (Level)	0.0 to 500.0 Hz	Y	Y	60.0	Y	Y	Y	Y	4-96
E37	Current Detection 2/ Low Current Detection (Level)	0.00 (Disable); Current value of 1% to 200% of the inverter rated current	Y	Y1 Y2	*2	Y	Y	Y	Y	4-96
E38	(Timer)	0.01 to 600.00 s	Y	Y	10.00	Y	Y	Y	Y	4-96
E40	PID Display Coefficient A	-999 to 0.00 to 9990	Y	Y	100	Y	Y	Y	N	4-96
E41	PID Display Coefficient B	-999 to 0.00 to 9990	Y	Y	0.00	Y	Y	Y	N	
E42	LED Display Filter	0.0 to 5.0 s	Y	Y	0.5	Y	Y	Y	Y	4-97
E43	LED Monitor (Item selection)	0: Speed monitor (select by E48) 3: Output current 4: Output voltage 8: Calculated torque 9: Input power 10: PID command 12: PID feedback amount 14: PID output 15: Load factor 16: Motor output 17: Analog input 23: Torque current (%) 24: Magnetic flux command (%) 25: Input watt-hour	Y	Y	0	Y	Y	Y	Y	4-98
E44	Display when stopped	0: Specified value 1: Output value	Y	Y	0	Y	Y	Y	Y	4-99
E45	LCD Monitor (Item selection)	0: Running status, rotational direction and operation guide 1: Bar charts for output frequency, current and calculated torque	Y	Y	0	Y	Y	Y	Y	
E46	Language selection	Type: TP-G1W-J1 0: Japanese 1: English 2: German 3: French 4: Spanish 5: Italian	Y	Y	1	Y	Y	Y	Y	4-100
E47	Contrast control	0 (Low) to 10 (High)	Y	Y	5	Y	Y	Y	Y	4-100
E48	LED Monitor(Speed monitor item)	0: Output frequency 1 (Before slip compensation) 1: Output frequency 2 (After slip compensation) 2: Reference frequency 3: Motor speed in r/min 4: Load shaft speed in r/min 5: Line speed in m/min 7: Display speed in %	Y	Y	0	Y	Y	Y	Y	

*2 The motor rated current is automatically set. See Table B (P03/A17).

Item values in parentheses indicated value for negative logic.

Y: Applicable / N: Not Applicable.

Code	Name	Data setting range	Change when running	Data copying	Default setting	Drive control				Refer to Page
						V/f	Vector Control w/o PG	w/ PG	Torque control	
E50	Coefficient for Speed Indication	0.01 to 200.00	Y	Y	30.00	Y	Y	Y	Y	4-100
E51	Display Coefficient for Input Watt-hour Data	0.000 (Cancel/reset), 0.001 to 9999	Y	Y	0.010	Y	Y	Y	Y	
E54	Frequency Detection 3 (Level)	0.0 to 500.0 Hz	Y	Y	60.0	Y	Y	Y	Y	4-101 4-94
E55	Current Detection 3 (Level)	0.00 (Disable); Current value of 1% to 200% of the inverter rated current	Y	Y1 Y2	*2	Y	Y	Y	Y	4-101 4-95
E56	(Timer)	0.01 to 600.00 s	Y	Y	10.00	Y	Y	Y	Y	4-102
E61	Terminal [12] Extended Function	0: None	N	Y	0	Y	Y	Y	Y	4-103
E62	Terminal Function [C1] Extended	1: Auxiliary frequency command 1 2: Auxiliary frequency command 2	N	Y	0	Y	Y	Y	Y	
E63	Terminal Function [V2] Extended	3: PID command 1 5: PID feedback amount 6: Ratio setting 7: Analog torque limit value A 8: Analog torque limit value B 10: Torque command 11: Torque current command 17: Speed limit FWD 18: Speed limit REV 20: Analog input monitor	N	Y	0	Y	Y	Y	Y	
E64	Saving of Digital Reference Frequency	0: Automatic saving (when main power is turned OFF) 1: Saving by pressing key	Y	Y	1	Y	Y	Y	Y	
E65	Reference Loss Detection (Continuous running frequency)	0: Decelerate to stop, 20% to 120%, 999: Disable	Y	Y	999	Y	Y	Y	Y	4-104
E78	Torque Detection 1 (Level)	0% to 300%	Y	Y	100	Y	Y	Y	Y	
E79	(Timer)	0.01 to 600.00 s	Y	Y	10.00	Y	Y	Y	Y	
E80	Torque Detection 2/ Low Torque Detection (Level)	0% to 300%	Y	Y	20	Y	Y	Y	Y	
E81	(Timer)	0.01 to 600.00 s	Y	Y	20.00	Y	Y	Y	Y	4-71 4-104
E98	Terminal [FWD] Function	Selecting function code data assigns the corresponding function to terminals [FWD] and [REV] as listed below. 0 (1000): Select multi-frequency (0 to 1 steps) (SS1)	N	Y	98	Y	Y	Y	N	
E99	Terminal [REV] Function	1 (1001): Select multi-frequency (0 to 3 steps) (SS2)	N	Y	99	Y	Y	Y	N	
		2 (1002): Select multi-frequency (0 to 7 steps) (SS4)				Y	Y	Y	N	
		3 (1003): Select multi-frequency (0 to 15 steps) (SS8)				Y	Y	Y	N	
		4 (1004): Select ACC/DEC time (2 steps) (RT1)				Y	Y	Y	N	
		5 (1005): Select ACC/DEC time (4 steps) (RT2)				Y	Y	Y	N	
		6 (1006): Enable 3-wire operation (HLD)				Y	Y	Y	Y	
		7 (1007): Coast to a stop (BX)				Y	Y	Y	Y	
		8 (1008): Reset alarm (RST)				Y	Y	Y	Y	
		9 (1009): Enable external alarm trip (THR) (9 = Active OFF, 1009 = Active ON)				Y	Y	Y	Y	
		10 (1010): Ready for jogging (JOG)				Y	Y	Y	N	
		11 (1011): Select frequency command 2/1 (Hz2/Hz1)				Y	Y	Y	N	
		12 (1012): Select motor 2 (M2)				Y	Y	Y	Y	
		13: Enable DC braking (DCBRK)				Y	Y	Y	N	
		14 (1014): Select torque limiter level 2/1 (TL2/TL1)				Y	Y	Y	Y	
		15: Switch to commercial power (50 Hz) (SW50)				Y	N	N	N	
		16: Switch to commercial power (60 Hz) (SW60)				Y	N	N	N	
		17 (1017): UP (Increase output frequency) (UP)				Y	Y	Y	N	
		18 (1018): DOWN (Decrease output frequency) (DOWN)				Y	Y	Y	N	
		19 (1019): Enable data change with keypad (WE-KP)				Y	Y	Y	Y	
		20 (1020): Cancel PID control (Hz/PID)				Y	Y	Y	N	
		21 (1021): Switch normal/inverse operation (IVS)				Y	Y	Y	N	
		22 (1022): Interlock (IL)				Y	Y	Y	Y	
		23 (1023): Cancel torque control (Hz/TRQ)				N	N	N	Y	
		24 (1024): Enable communications link via RS-485 or fieldbus (LE)				Y	Y	Y	Y	
		25 (1025): Universal DI (U-DI)				Y	Y	Y	Y	
		26 (1026): Enable auto search for idling motor speed at starting (STM)				Y	Y	N	Y	

The shaded function codes are applicable to the quick setup.

*2 The motor rated current is automatically set. See Table B (P03/A17).

Item values in parentheses indicated value for negative logic.

Y: Applicable / N: Not Applicable.

Code	Name	Data setting range	Change when running	Data copying	Default setting	Drive control				Refer to Page
						V/f	Vector Control w/o PG	w/ PG	Torque control	
		30 (1030): Force to stop (STOP) (30 = Active OFF, 1030 = Active ON)				Y	Y	Y	Y	4-71 4-104
		32 (1032): Pre-excitation (EXITE)				N	Y	Y	N	
		33 (1033): Reset PID integral and differential components (PID-RST)				Y	Y	Y	N	
		34 (1034): Hold PID integral component (PID-HLD)				Y	Y	Y	N	
		35 (1035): Select local (keypad) operation (LOC)				Y	Y	Y	Y	
		39: Protect motor from dew condensation (DWP)				Y	Y	Y	Y	
		40: Enable integrated sequence to switch to commercial power (50 Hz) (ISW50)				Y	N	N	N	
		41: Enable integrated sequence to switch to commercial power (60 Hz) (ISW60)				Y	N	N	N	
		47 (1047): Servo-lock command (LOCK)				N	N	Y	N	
		49 (1049): Pulse train sign (SIGN)				Y	Y	Y	Y	
		59 (1059): Enabled battery operation (BATRY)				Y	Y	Y	Y	
		70 (1070): Cancel constant peripheral speed control (Hz/LSC)				Y	Y	Y	N	
		71 (1071): Hold the constant peripheral speed control frequency in the memory (LSC-HLD)				Y	Y	Y	N	
		72 (1072): Count the run time of commercial power-driven motor 1 (CRUN-M1)				Y	N	N	Y	
		73 (1073): Count the run time of commercial power-driven motor 2 (CRUN-M2)				Y	N	N	Y	
		76 (1076): Select droop control (DROOP)				Y	Y	Y	N	
		77 (1077): Cancel PG alarm (PG-CCL)				N	N	Y	Y	
		80 (1080): Cancel customizable logic (CLC)				Y	Y	Y	Y	
		81 (1081): Clear all customizable logic timers (CLTC)				Y	Y	Y	Y	
		98: Run forward (FWD)				Y	Y	Y	Y	
		99: Run reverse (REV)				Y	Y	Y	Y	
		100: No function assigned (NONE)				Y	Y	Y	Y	
		Setting the value in parentheses () shown above assigns a negative logic input to a terminal.								

Item values in parentheses indicated value for negative logic.

Y: Applicable / N: Not Applicable.

C codes: Control Functions of Frequency

Code	Name	Data setting range	Change when running	Data copying	Default setting	Drive control				Refer to Page	
						V/f	Vector Control w/o PG	w/ PG	Torque control		
C01	Jump Frequency	0.0 to 500.0 Hz	Y	Y	0.0	Y	Y	Y	N	4-105	
C02			2	Y	Y	0.0	Y	Y	Y		N
C03			3	Y	Y	0.0	Y	Y	Y		N
C04	(Hysteresis width)	0.0 to 30.0 Hz	Y	Y	3.0	Y	Y	Y	N		
C05	Multi-frequency	0.00 to 500.00 Hz	Y	Y	0.00	Y	Y	Y	N		
C06			2	Y	Y	0.00	Y	Y	Y		N
C07			3	Y	Y	0.00	Y	Y	Y		N
C08			4	Y	Y	0.00	Y	Y	Y		N
C09			5	Y	Y	0.00	Y	Y	Y		N
C10			6	Y	Y	0.00	Y	Y	Y		N
C11			7	Y	Y	0.00	Y	Y	Y		N
C12			8	Y	Y	0.00	Y	Y	Y		N
C13			9	Y	Y	0.00	Y	Y	Y		N
C14			10	Y	Y	0.00	Y	Y	Y		N
C15			11	Y	Y	0.00	Y	Y	Y		N
C16			12	Y	Y	0.00	Y	Y	Y	N	
C17			13	Y	Y	0.00	Y	Y	Y	N	
C18			14	Y	Y	0.00	Y	Y	Y	N	
C19			15	Y	Y	0.00	Y	Y	Y	N	
C20	Jogging Frequency	0.00 to 500.00 Hz	Y	Y	0.00	Y	Y	Y	N	4-107	
C30	Frequency Command 2	0: Enable ☺ / ☹ keys on the keypad 1: Voltage input to terminal [12] (-10 to +10 VDC) 2: Current input to terminal [C1] (4 to 20 mA DC) 3: Sum of voltage and current inputs to terminals [12]and [C1] 5: Voltage input to terminal [V2] (-10 to +10 VDC) 7: Terminal command UP/DOWN control 8: Enable ☺ / ☹ keys on the keypad (balanceless-bumpless switching available) 11: Digital input interface card (option) 12: Pulse train input	N	Y	2	Y	Y	Y	N	4-26 4-107	
C31	Analog Input Adjustment for [12] (Offset)	-5.0% to 5.0%	Y*	Y	0.0	Y	Y	Y	Y	4-107	
C32		(Gain)	0.00% to 400.00%	Y*	Y	100.00	Y	Y	Y		Y
C33		(Filter time constant)	0.00 to 5.00 s	Y	Y	0.05	Y	Y	Y		Y
C34		(Gain base point)	0.00% to 100.00%	Y*	Y	100.00	Y	Y	Y		Y
C35		(Polarity)	0: Bipolar 1: Unipolar	N	Y	1	Y	Y	Y		Y
C36	Analog Input Adjustment for [C1] (Offset)	-5.0% to 5.0%	Y*	Y	0.0	Y	Y	Y	Y	4-26 4-107	
C37		(Gain)	0.00% to 400.00%	Y*	Y	100.00	Y	Y	Y		Y
C38		(Filter time constant)	0.00 to 5.00s	Y	Y	0.05	Y	Y	Y		Y
C39		(Gain base point)	0.00% to 100.00%	Y*	Y	100.00	Y	Y	Y		Y
C40	Terminal [C1] Range Selection	0: 4 to 20 mA 1: 0 to 20 mA	N	Y	0	Y	Y	Y	Y		
C41	Analog Input Adjustment for [V2] (Offset)	-5.0% to 5.0%	Y*	Y	0.0	Y	Y	Y	Y	4-26 4-108	
C42		(Gain)	0.00% to 400.00%	Y*	Y	100.00	Y	Y	Y		Y
C43		(Filter time constant)	0.00 to 5.00 s	Y	Y	0.05	Y	Y	Y		Y
C44		(Gain base point)	0.00% to 100.00%	Y*	Y	100.00	Y	Y	Y		Y
C45		(Polarity)	0: Bipolar 1: Unipolar	N	Y	1	Y	Y	Y		Y
C50	Bias (Frequency command 1) (Bias base point)	0.00% to 100.00%	Y*	Y	0.00	Y	Y	Y	Y		
C51	Bias (PID command 1)(Bias value)	-100.00% to 100.00%	Y*	Y	0.00	Y	Y	Y	Y		
C52	(Bias base point)	0.00% to 100.00%	Y*	Y	0.00	Y	Y	Y	Y	4-108	
C53	Selection of Normal/Inverse Operation(Frequency command 1)	0: Normal operation 1: Inverse operation	Y	Y	0	Y	Y	Y	Y	4-71 4-108	

Y: Applicable / N: Not Applicable.

P codes: Motor 1 Parameters

Code	Name	Data setting range	Change when running	Data copying	Default setting	Drive control			Refer to Page
						V/f	Vector Control w/o PG	w/ PG	
P01	Motor 1 (No. of poles)	2 to 22 poles	N	Y1 Y2	4	Y	Y	Y	4-109
P02	(Rated capacity)	0.01 to 1000 kW (when P99 = 0, 2, 3 or 4) 0.01 to 1000 HP (when P99 = 1)	N	Y1 Y2	*7	Y	Y	Y	4-109
P03	(Rated current)	0.00 to 2000 A	N	Y1 Y2	*7	Y	Y	Y	
P04	(Auto-tuning)	0: Disable 1: Tune while the motor stops. (%R1, %X and rated slip frequency) 2: Tune while the motor is rotating under V/f control (%R1, %X, rated slip frequency, no-load current, magnetic saturation factors 1 to 5, and magnetic saturation extension factors "a" to "c") 3: Tune while the motor is rotating under vector control (%R1, %X, rated slip frequency, no-load current, magnetic saturation factors 1 to 5, and magnetic saturation extension factors "a" to "c." Available when the vector control is enabled.)	N	N	0	Y	Y	Y	4-110
P05	(Online tuning)	0: Disable 1: Enable	Y	Y	0	Y	N	N	4-111
P06	(No-load current)	0.00 to 2000 A	N	Y1 Y2	*7	Y	Y	Y	
P07	(%R1)	0.00% to 50.00%	Y	Y1 Y2	*7	Y	Y	Y	
P08	(%X)	0.00% to 50.00%	Y	Y1 Y2	*7	Y	Y	Y	
P09	(Slip compensation gain for driving)	0.0% to 200.0%	Y*	Y	100.0	Y	Y	Y	4-112
P10	(Slip compensation response time)	0.01 to 10.00 s	Y	Y1 Y2	0.12	Y	N	N	
P11	(Slip compensation gain for braking)	0.0% to 200.0%	Y*	Y	100.0	Y	Y	Y	
P12	(Rated slip frequency)	0.00 to 15.00 Hz	N	Y1 Y2	*7	Y	Y	Y	
P13	(Iron loss factor 1)	0.00% to 20.00%	Y	Y1 Y2	*7	Y	Y	Y	
P14	(Iron loss factor 2)	0.00% to 20.00%	Y	Y1 Y2	0.00	Y	Y	Y	
P15	(Iron loss factor 3)	0.00% to 20.00%	Y	Y1 Y2	0.00	Y	Y	Y	
P16	(Magnetic saturation factor 1)	0.0% to 300.0%	Y	Y1 Y2	*7	Y	Y	Y	
P17	(Magnetic saturation factor 2)	0.0% to 300.0%	Y	Y1 Y2	*7	Y	Y	Y	
P18	(Magnetic saturation factor 3)	0.0% to 300.0%	Y	Y1 Y2	*7	Y	Y	Y	
P19	(Magnetic saturation factor 4)	0.0% to 300.0%	Y	Y1 Y2	*7	Y	Y	Y	
P20	(Magnetic saturation factor 5)	0.0% to 300.0%	Y	Y1 Y2	*7	Y	Y	Y	
P21	(Magnetic saturation extension factor "a")	0.0% to 300.0%	Y	Y1 Y2	*7	Y	Y	Y	
P22	(Magnetic saturation extension factor "b")	0.0% to 300.0%	Y	Y1 Y2	*7	Y	Y	Y	
P23	(Magnetic saturation extension factor "c")	0.0% to 300.0%	Y	Y1 Y2	*7	Y	Y	Y	
P53	(%X correction factor 1)	0% to 300%	Y	Y1 Y2	100	Y	Y	Y	4-113
P54	(%X correction factor 2)	0% to 300%	Y	Y1 Y2	100	Y	Y	Y	
P55	(Torque current under vector control)	0.00 to 2000 A	N	Y1 Y2	*7	N	Y	Y	
P56	(Induced voltage factor under vector control)	50% to 100%	N	Y1 Y2	85 (90) *8	N	Y	Y	
P57	Reserved *9	—	-	-	-	-	-	-	—
P99	Motor 1 Selection	0: Motor characteristics 0 (Reserved) 1: Motor characteristics 1 (HP rating motors) 2: Motor characteristics 2 (Reserved) 3: Motor characteristics 3 (Reserved) 4: Motor characteristics 1 (kW rating motors)	N	Y1 Y2	1	Y	Y	Y	4-113

The shaded function code are applicable to the quick setup.

*7 The motor parameters are automatically set, depending upon the inverter's capacity. See Table B.

*8 85% for inverters of 150 HP or less; 90% for those of 175 HP or above.

*9 Factory use. Do not access these function codes.

The shaded function codes are applicable to the quick setup.

Y: Applicable / N: Not Applicable.

H codes: High Performance Functions

Code	Name	Data setting range	Change when running	Data copying	Default setting	Drive control				Refer to Page
						V/f	Vector Control w/o PG	w/ PG	Torque control	
H03	Data Initialization	0: Disable initialization 1: Initialize all function code data to the factory defaults 2: Initialize motor 1 parameters 3: Initialize motor 2 parameters	N	N	0	Y	Y	Y	Y	*11
H04	Auto-reset (Times)	0: Disable; 1 to 10	Y	Y	0	Y	Y	Y	Y	
H05	(Reset interval)	0.5 to 20.0 s	Y	Y	5.0	Y	Y	Y	Y	
H06	Cooling Fan ON/OFF Control	0: Disable (Always in operation) 1: Enable (ON/OFF controllable)	Y	Y	0	Y	Y	Y	Y	
H07	Acceleration/Deceleration Pattern	0: Linear 1: S-curve (Weak) 2: S-curve (Arbitrary, according to H57 to H60 data) 3: Curvilinear	Y	Y	0	Y	Y	Y	N	
H08	Rotational Direction Limitation	0: Disable 1: Enable (Reverse rotation inhibited) 2: Enable (Forward rotation inhibited)	N	Y	0	Y	Y	Y	N	
H09	Starting Mode (Auto search)	0: Disable 1: Enable (At restart after momentary power failure) 2: Enable (At restart after momentary power failure and at normal start)	N	Y	0	Y	N	N	N	
H11	Deceleration Mode	0: Normal deceleration 1: Coast-to-stop	Y	Y	0	Y	Y	Y	N	
H12	Instantaneous Overcurrent Limiting (Mode selection)	0: Disable 1: Enable	Y	Y	1	Y	N	N	N	
H13	Restart Mode after Momentary Power Failure (Restart time)	0.1 to 20.0 s	Y	Y1 Y2	*10	Y	Y	Y	N	
H14	(Frequency fall rate)	0.00: Deceleration time selected by F08, 0.01 to 100.00 Hz/s, 999: Follow the current limit command	Y	Y	999	Y	Y	N	N	
H15	(Continuous running level)	200 to 300 V for 230 V series 400 to 600 V for 460 V series	Y	Y2	235 470	Y	N	N	N	
H16	(Allowable momentary power failure time)	0.0 to 30.0 s 999: Automatically determined by inverter	Y	Y	999	Y	Y	Y	N	
H18	Torque Control (Mode selection)	0: Disable (Speed control) 2: Enable (Torque current command) 3: Enable (Torque command)	N	Y	0	N	Y	Y	Y	
H26	Thermistor (for motor) (Mode selection)	0: Disable 1: PTC (The inverter immediately trips with <i>Oh4</i> displayed.) 2: PTC (The inverter issues output signal THM and continues to run.) 3: NTC (When connected)	Y	Y	0	Y	Y	Y	Y	
H27	(Level)	0.00 to 5.00 V	Y	Y	0.35	Y	Y	Y	Y	
H28	Droop Control	-60.0 to 0.0 Hz	Y	Y	0.0	Y	Y	Y	N	
H30	Communications Link Function (Mode selection)	Frequency command Run command 0: F01/C30 F02 1: RS-485 (Port 1) F02 2: F01/C30 RS-485 (Port 1) 3: RS-485 (Port 1) RS-485 (Port 1) 4: RS-485 (Port 2) F02 5: RS-485 (Port 2) RS-485 (Port 1) 6: F01/C30 RS-485 (Port 2) 7: RS-485 (Port 1) RS-485 (Port 2) 8: RS-485 (Port 2) RS-485 (Port 2)	Y	Y	0	Y	Y	Y	Y	
H42	Capacitance of DC Link Bus Capacitor	Indication for replacement of DC link bus capacitor 0 to 65535	Y	N	-	Y	Y	Y	Y	
H43	Cumulative Run Time of Cooling Fan	Indication for replacement of cooling fan 0 to 99990 hours	Y	N	-	Y	Y	Y	Y	
H44	Startup Counter for Motor 1	Indication of cumulative startup count 0 to 65535 times	Y	N	-	Y	Y	Y	Y	
H45	Mock Alarm	0: Disable 1: Enable (Once a mock alarm occurs, the data automatically returns to 0.)	Y	N	0	Y	Y	Y	Y	
H46	Starting Mode (Auto search delay time 2)	0.1 to 20.0 s	Y	Y1 Y2	*7	Y	Y	N	Y	
H47	Initial Capacitance of DC Link Bus Capacitor	Indication for replacement of DC link bus capacitor 0 to 65535	Y	N	-	Y	Y	Y	Y	
H48	Cumulative Run Time of Capacitors on Printed Circuit Boards	Indication for replacement of capacitors 0 to 99990 hours (The cumulative run time can be modified or reset.)	Y	N	-	Y	Y	Y	Y	

*7 The motor parameters are automatically set, depending upon the inverter's capacity. See Table B.

*10The factory default differs depending upon the inverter's capacity. See Table A.

*11 Refer to the User Manual for detailed information on these parameters.

Y: Applicable / N: Not Applicable.

Code	Name	Data setting range	Change when running	Data copying	Default setting	Drive control				Refer to Page
						V/f	Vector Control w/o PG	w/ PG	Torque control	
H49	Starting Mode (Auto search delay time 1)	0.0 to 10.0 s	Y	Y	0.0	Y	Y	Y	Y	*11
H50	Non-linear V/f Pattern 1 (Frequency)	0.0: Cancel, 0.1 to 500.0 Hz	N	Y	0.0	Y	N	N	N	
H51	(Voltage)	0 to 240: Output an AVR-controlled voltage (for 230 V series) 0 to 500: Output an AVR-controlled voltage (for 460 V series)	N	Y2	0	Y	N	N	N	
H52	Non-linear V/f Pattern 2 (Frequency)	0.0: Cancel, 0.1 to 500.0 Hz	N	Y	0.0	Y	N	N	N	
H53	(Voltage)	0 to 240: Output an AVR-controlled voltage (for 230 V series) 0 to 500: Output an AVR-controlled voltage (for 460 V series)	N	Y2	0	Y	N	N	N	
H54	Acceleration Time (Jogging)	0.00 to 6000 s	Y	Y	*1	Y	Y	Y	N	
H55	Deceleration Time (Jogging)	0.00 to 6000 s	Y	Y	*1	Y	Y	Y	N	
H56	Deceleration Time for Forced Stop	0.00 to 6000 s	Y	Y	*1	Y	Y	Y	N	
H57	1st S-curve acceleration range (Leading edge)	0% to 100%	Y	Y	10	Y	Y	Y	N	
H58	2nd S-curve acceleration range (Trailing edge)	0% to 100%	Y	Y	10	Y	Y	Y	N	
H59	1st S-curve deceleration range (Leading edge)	0% to 100%	Y	Y	10	Y	Y	Y	N	
H60	2nd S-curve deceleration range (Trailing edge)	0% to 100%	Y	Y	10	Y	Y	Y	N	
H61	UP/DOWN Control (Initial frequency setting)	0: 0.00 Hz 1: Last UP/DOWN command value on releasing the run command	N	Y	1	Y	Y	Y	N	
H63	Low Limiter (Mode selection)	0: Limit by F16 (Frequency limiter: Low) and continue to run 1: If the output frequency lowers below the one limited by F16 (Frequency limiter: Low), decelerate to stop the motor.	Y	Y	0	Y	Y	Y	N	
H64	(Lower limiting frequency)	0.0: Depends on F16 (Frequency limiter, Low) 0.1 to 60.0 Hz	Y	Y	1.6	Y	N	N	N	
H65	Non-linear V/f Pattern 3 (Frequency)	0.0: Cancel, 0.1 to 500.0 Hz	N	Y	0.0	Y	N	N	N	
H66	(Voltage)	0 to 240: Output an AVR-controlled voltage (for 230 V series) 0 to 500: Output an AVR-controlled voltage (for 460 V series)	N	Y2	0	Y	N	N	N	
H67	Auto Energy Saving Operation (Mode selection)	0: Enable during running at constant speed 1: Enable in all modes	Y	Y	0	Y	N	Y	N	
H68	Slip Compensation 1 (Operating conditions)	0: Enable during ACC/DEC and at base frequency or above 1: Disable during ACC/DEC and enable at base frequency or above 2: Enable during ACC/DEC and disable at base frequency or above 3: Disable during ACC/DEC and at base frequency or above	N	Y	0	Y	N	N	N	
H69	Automatic Deceleration (Mode selection)	0: Disable 2: Torque limit control with Force-to-stop if actual deceleration time exceeds three times the specified one 3: DC link bus voltage control with Force-to-stop if actual deceleration time exceeds three times the specified one 4: Torque limit control with Force-to-stop disabled 5: DC link bus voltage control with Force-to-stop disabled	Y	Y	0	Y	Y	Y	N	
H70	Overload Prevention Control	0.00: Follow the deceleration time selected 0.01 to 100.0 Hz/s 999: Cancel	Y	Y	999	Y	Y	Y	N	
H71	Deceleration Characteristics	0: Disable 1: Enable	Y	Y	0	Y	N	N	N	
H72	Main Power Down Detection (Mode selection)	0: Disable 1: Enable	Y	Y	1	Y	Y	Y	Y	

*1 6.00 s for inverters of 40 HP or below; 20.00 s for those of 50 HP or above.

*11 Refer to the User Manual for detailed information on these parameters.

Y: Applicable / N: Not Applicable.

Code	Name	Data setting range	Change when running	Data copying	Default setting	Drive Control				Refer to Page
						V/f	Vector Control w/o PG	w/ PG	Torque control	
H73	Torque Limiter (Operating conditions)	0: Enable during ACC/DEC and running at constant speed 1: Disable during ACC/DEC and enable during running at constant speed 2: Enable during ACC/DEC and disable during running at constant speed	N	Y	0	Y	Y	Y	Y	*11
H74	(Control target)	0: Motor-generating torque limit 1: Torque current limit 2: Output power limit	N	Y	1	N	Y	Y	Y	
H75	(Target quadrants)	0: Drive/brake 1: Same for all four quadrants 2: Upper/lower limits	N	Y	0	N	Y	Y	Y	
H76	(Frequency increment limit for braking)	0.0 to 500.0 Hz	Y	Y	5.0	Y	N	N	N	
H77	Service Life of DC Link Bus Capacitor (Remaining time)	0 to 87600 hours	Y	N	-	Y	Y	Y	Y	
H78	Maintenance Interval (M1)	0: Disable; 1 to 99990 hours	Y	N	87600	Y	Y	Y	Y	
H79	Preset Startup Count for Maintenance (M1)	0: Disable; 1 to 65535 times	Y	N	0	Y	Y	Y	Y	
H80	Output Current Fluctuation Damping Gain for Motor 1	0.00 to 1.00	Y	Y	0.20	Y	N	N	Y	
H81	Light Alarm Selection 1	0000 to FFFF (hex.)	Y	Y	0	Y	Y	Y	Y	
H82	Light Alarm Selection 2	0000 to FFFF (hex.)	Y	Y	0	Y	Y	Y	Y	
H84	Pre-excitation (Initial level)	100% to 400%	Y	Y	100	N	Y	Y	Y	
H85	(Time)	0.00: Disable; 0.01 to 30.00 s	Y	Y	0.00	N	Y	Y	Y	
H86	Reserved *9	—	-	-	-	-	-	-	-	
H87	Reserved *9	—	-	-	-	-	-	-	-	
H88	Reserved *9	—	-	-	-	-	-	-	-	
H89	Reserved *9	—	-	-	-	-	-	-	-	
H90	Reserved *9	—	-	-	-	-	-	-	-	
H91	PID Feedback Wire Break Detection	0.0: Disable alarm detection 0.1 to 60.0 s	Y	Y	0.0	Y	Y	Y	N	
H92	Continuity of Running (P)	0.000 to 10.000 times; 999	Y	Y1Y2	999	Y	N	N	N	
H93	(I)	0.010 to 10.000 s; 999	Y	Y1Y2	999	Y	N	N	N	
H94	Cumulative Motor Run Time 1	0 to 99990 hours (The cumulative run time can be modified or reset.)	N	N	-	Y	Y	Y	Y	
H95	DC Braking (Braking response mode)	0: Slow 1: Quick	Y	Y	1	Y	N	N	N	
H96	STOP Key Priority/ Start Check Function	Data STOP key priority Start check function 0: Disable Disable 1: Enable Disable 2: Disable Enable 3: Enable Enable	Y	Y	3	Y	Y	Y	Y	
H97	Clear Alarm Data	0: Disable 1: Enable (Setting "1" clears alarm data and then returns to "0.")	Y	N	0	Y	Y	Y	Y	
H98	Protection/Maintenance Function (Mode selection)	0 to 255: Display data in decimal format Bit 0: Lower the carrier frequency automatically (0: Disabled; 1: Enabled) Bit 1: Detect input phase loss (0: Disabled; 1: Enabled) Bit 2: Detect output phase loss (0: Disabled; 1: Enabled) Bit 3: Select life judgment threshold of DC link bus capacitor (0: Factory default level; 1: User setup level) Bit 4: Judge the life of DC link bus capacitor (0: Disabled; 1: Enabled) Bit 5: Detect DC fan lock (0: Enabled; 1: Disabled) Bit 6: Detect braking transistor error (for 40 HP or below) (0: Disabled; 1: Enabled) Bit 7: Switch IP20/IP40 enclosure (0: IP20; 1: IP40)	Y	Y	83	Y	Y	Y	Y	

*9 Factory use. Do not access these function codes.

*11 Refer to the User Manual for detailed information on these parameters.

Y: Applicable / N: Not Applicable.

A codes: Motor 2 Parameters

Code	Name	Data setting range	Change when running	Data copying	Default setting	Drive Control				Refer to Page
						V/f	Vector Control w/o PG	w/ PG	Torque control	
A01	Maximum Frequency 2	25.0 to 500.0 Hz	N	Y	60.0	Y	Y	Y	Y	*11
A02	Base Frequency 2	25.0 to 500.0 Hz	N	Y	60.0	Y	Y	Y	Y	
A03	Rated Voltage at Base Frequency 2	0: Output a voltage in proportion to input voltage 80 to 240: Output an AVR-controlled voltage (for 230 V series) 160 to 500: Output an AVR-controlled voltage (for 460 V series)	N	Y2	230 460	Y	Y	Y	Y	
A04	Maximum Output Voltage 2	80 to 240: Output an AVR-controlled voltage (for 230 V series) 160 to 500: Output an AVR-controlled voltage (for 460 V series)	N	Y2	230 460	Y	N	N	Y	
A05	Torque Boost 2	0.0% to 20.0% (percentage with respect to "A03: Rated Voltage at Base Frequency 2")	Y	Y	0.0	Y	N	N	N	
A06	Electronic Thermal Overload Protection for Motor 2 (Select motor characteristics)	1: For a general-purpose motor with shaft-driven cooling fan 2: For an inverter-driven motor, non-ventilated motor, or motor with separately powered cooling fan	Y	Y	1	Y	Y	Y	Y	
A07	(Overload detection level)	0.00: Disable 1% to 135% of the rated current (allowable continuous drive current) of the motor	Y	Y1 Y2	*2	Y	Y	Y	Y	
A08	(Thermal time constant)	0.5 to 75.0 min	Y	Y	*3	Y	Y	Y	Y	
A09	DC Braking 2 (Braking starting frequency)	0.0 to 60.0 Hz	Y	Y	0.0	Y	Y	Y	N	
A10	(Braking level)	0% to 80% (LD/MD mode)*4, 0% to 100% (HD mode)	Y	Y	0	Y	Y	Y	N	
A11	(Braking time)	0.00: Disable; 0.01 to 30.00 s	Y	Y	0.00	Y	Y	Y	N	
A12	Starting Frequency 2	0.0 to 60.0 Hz	Y	Y	0.5	Y	Y	Y	N	
A13	Load Selection/ Auto Torque Boost Auto Energy Saving Operation 2	0: Variable torque load 1: Constant torque load 2: Auto-torque boost 3: Auto-energy saving operation (Variable torque load during ACC/DEC) 4: Auto-energy saving operation (Constant torque load during ACC/DEC) 5: Auto-energy saving operation (Auto-torque boost during ACC/DEC)	N	Y	1	Y	N	Y	N	
A14	Drive Control Selection 2	0: V/f control with slip compensation inactive 1: Dynamic torque control 5: Vector control without speed sensor 6: Vector control with speed sensor	N	Y	0	Y	Y	Y	Y	
A15	Motor 2 (No. of poles)	2 to 22 poles	N	Y1 Y2	4	Y	Y	Y	Y	
A16	(Rated capacity)	0.01 to 1000 kW (when A39 = 0, 2, 3 or 4) 0.01 to 1000 HP (when A39 = 1)	N	Y1 Y2	*7	Y	Y	Y	Y	
A17	(Rated current)	0.00 to 2000 A	N	Y1 Y2	*7	Y	Y	Y	Y	

*2 The motor rated current is automatically set. See Table B (P03/A17).

*3 5.0 min for inverters of 40 HP or below; 10.0 min for those of 50 HP or above.

*4 0% to 100% for inverters of 7.5 HP or below.

*7 The motor parameters are automatically set, depending upon the inverter's capacity. See Table B.

*11 Refer to the User Manual for detailed information on these parameters.

Y: Applicable / N: Not Applicable.

Code	Name	Data setting range	Change when running	Data copying	Default setting	Drive Control				Refer to Page
						V/f	Vector Control	w/ PG	Torque control	
							w/o PG			
A18	Motor 2 (Auto-tuning)	0: Disable 1: Tune while the motor stops. (%R1, %X and rated slip frequency) 2: Tune while the motor is rotating under V/f control (%R1, %X, rated slip frequency, no-load current, magnetic saturation factors 1 to 5, and magnetic saturation extension factors "a" to "c") 3: Tune while the motor is rotating under vector control (%R1, %X, rated slip frequency, no-load current, magnetic saturation factors 1 to 5, and magnetic saturation extension factors "a" to "c." Available when the vector control is enabled.	N	N	0	Y	Y	Y	Y	*11
A19	(Online tuning)	0: Disable 1: Enable	Y	Y	0	Y	N	N	N	
A20	(No-load current)	0.00 to 2000 A	N	Y1 Y2	*7	Y	Y	Y	Y	
A21	(%R1)	0.00% to 50.00%	Y	Y1 Y2	*7	Y	Y	Y	Y	
A22	(%X)	0.00% to 50.00%	Y	Y1 Y2	*7	Y	Y	Y	Y	
A23	(Slip compensation gain for driving)	0.0% to 200.0%	Y*	Y	100.0	Y	Y	Y	N	
A24	(Slip compensation response time)	0.01 to 10.00s	Y	Y1 Y2	0.12	Y	N	N	N	
A25	(Slip compensation gain for braking)	0.0% to 200.0%	Y*	Y	100.0	Y	Y	Y	N	
A26	(Rated slip frequency)	0.00 to 15.00 Hz	N	Y1 Y2	*7	Y	Y	Y	N	
A27	(Iron loss factor 1)	0.00% to 20.00%	Y	Y1 Y2	*7	Y	Y	Y	Y	
A28	(Iron loss factor 2)	0.00% to 20.00%	Y	Y1 Y2	0.00	Y	Y	Y	Y	
A29	(Iron loss factor 3)	0.00% to 20.00%	Y	Y1 Y2	0.00	Y	Y	Y	Y	
A30	(Magnetic saturation factor 1)	0.0% to 300.0%	Y	Y1 Y2	*7	Y	Y	Y	Y	
A31	(Magnetic saturation factor 2)	0.0% to 300.0%	Y	Y1 Y2	*7	Y	Y	Y	Y	
A32	(Magnetic saturation factor 3)	0.0% to 300.0%	Y	Y1 Y2	*7	Y	Y	Y	Y	
A33	(Magnetic saturation factor 4)	0.0% to 300.0%	Y	Y1 Y2	*7	Y	Y	Y	Y	
A34	(Magnetic saturation factor 5)	0.0% to 300.0%	Y	Y1 Y2	*7	Y	Y	Y	Y	
A35	(Magnetic saturation extension factor "a")	0.0% to 300.0%	Y	Y1 Y2	*7	Y	Y	Y	Y	
A36	(Magnetic saturation extension factor "b")	0.0% to 300.0%	Y	Y1 Y2	*7	Y	Y	Y	Y	
A37	(Magnetic saturation extension factor "c")	0.0% to 300.0%	Y	Y1 Y2	*7	Y	Y	Y	Y	
A39	Motor 2 Selection	0: Motor characteristics 0 (Consult Factory) 1: Motor characteristics 1 (HP rating motors) 2: Motor characteristics 2 (Consult Factory) 3: Motor characteristics 3 (Consult Factory) 4: Consult Factory	N	Y1 Y2	1	Y	Y	Y	Y	
A40	Slip Compensation 2 (Operating conditions)	0: Enable during ACC/DEC and at base frequency or above 1: Disable during ACC/DEC and enable at base frequency or above 2: Enable during ACC/DEC and disable at base frequency or above 3: Disable during ACC/DEC and at base frequency or above	N	Y	0	Y	N	N	N	
A41	Output Current Fluctuation Damping Gain for Motor 2	0.00 to 1.00	Y	Y	0.20	Y	N	N	N	
A42	Motor/Parameter Switching 2 (Mode selection)	0: Motor (Switch to the 2nd motor) 1: Parameter (Switch to particular A codes)	N	Y	0	Y	Y	Y	Y	4-73
A43	Speed Control 2 (Speed command filter)	0.000 to 5.000 s	Y	Y	0.020	N	Y	Y	N	*11
A44	(Speed detection filter)	0.000 to 0.100 s	Y*	Y	0.005	N	Y	Y	N	
A45	P (Gain)	0.1 to 200.0 times	Y*	Y	10.0	N	Y	Y	N	
A46	I (Integral time)	0.001 to 9.999 s 999: Disable integral action	Y*	Y	0.100	N	Y	Y	N	
A48	(Output filter)	0.000 to 0.100 s	Y	Y	0.002	N	Y	Y	N	
A49	(Notch filter resonance frequency)	1 to 200 Hz	Y	Y	200	N	N	Y	N	
A50	(Notch filter attenuation level)	0 to 20 dB	Y	Y	0	N	N	Y	N	
A51	Cumulative Motor Run Time 2	0 to 99990 hours (The cumulative run time can be modified or reset.)	N	N	-	Y	Y	Y	Y	
A52	Startup Counter for Motor 2	Indication of cumulative startup count 0 to 65535 times	Y	N	-	Y	Y	Y	Y	

Code	Name	Data setting range	Change when running	Data copying	Default setting	Drive Control			Refer to Page
						V/f	Vector Control w/o PG	w/ PG	
A53	Motor 2 (%X correction factor 1)	0% to 300%	Y	Y1 Y2	100	Y	Y	Y	*11
A54	(%X correction factor 2)	0% to 300%	Y	Y1 Y2	100	Y	Y	Y	
A55	(Torque current under vector control)	0.00 to 2000 A	N	Y1 Y2	*7	N	Y	Y	
A56	(Induced voltage factor under vector control)	50 to 100	N	Y1 Y2	85 (90) *8	N	Y	Y	
A57	Reserved *9	—	-	-	-	-	-	-	

*7 The motor parameters are automatically set, depending upon the inverter's capacity. See Table B.

*8 85% for inverters of 150 HP or less; 90% for those of 175 HP or above.

*9 Factory use. Do not access these function codes.

*11 Refer to the User Manual for detailed information on these parameters.

Y: Applicable / N: Not Applicable.

J codes: Application Functions 1

Code	Name	Data setting range	Change when running	Data copying	Default setting	Drive Control				Refer to Page
						V/f	Vector Control w/o PG	w/ PG	Torque control	
J01	PID Control (Mode selection)	0: Disable 1: Enable (Process control, normal operation) 2: Enable (Process control, inverse operation) 3: Enable (Dancer control)	N	Y	0	Y	Y	Y	N	*11
J02	(Remote command SV)	0: ⏏ / ⏏ keys on keypad 1: PID command 1 (Analog input terminals [12], [C1], and [V2]) 3: UP/DOWN 4: Command via communications link	N	Y	0	Y	Y	Y	N	
J03	P (Gain)	0.000 to 30.000 times	Y	Y	0.100	Y	Y	Y	N	
J04	I (Integral time)	0.0 to 3600.0 s	Y	Y	0.0	Y	Y	Y	N	
J05	D (Differential time)	0.00 to 600.00 s	Y	Y	0.00	Y	Y	Y	N	
J06	(Feedback filter)	0.0 to 900.0 s	Y	Y	0.5	Y	Y	Y	N	
J08	(Pressurization starting frequency)	0.0 to 500.0 Hz	Y	Y	0.0	Y	Y	Y	N	
J09	(Pressurizing time)	0 to 60 s	Y	Y	0	Y	Y	Y	N	
J10	(Anti reset windup)	0% to 200%	Y	Y	200	Y	Y	Y	N	
J11	(Select alarm output)	0: Absolute-value alarm 1: Absolute-value alarm (with Hold) 2: Absolute-value alarm (with Latch) 3: Absolute-value alarm (with Hold and Latch) 4: Deviation alarm 5: Deviation alarm (with Hold) 6: Deviation alarm (with Latch) 7: Deviation alarm (with Hold and Latch)	Y	Y	0	Y	Y	Y	N	
J12	(Upper level alarm (AH))	-100% to 100%	Y	Y	100	Y	Y	Y	N	
J13	(Lower level alarm (AL))	-100% to 100%	Y	Y	0	Y	Y	Y	N	
J15	(Stop frequency for slow flowrate)	0.0: Disable; 1.0 to 500.0 Hz	Y	Y	0.0	Y	Y	Y	N	
J16	(Slow flowrate level stop latency)	0 to 60 s	Y	Y	30	Y	Y	Y	N	
J17	(Starting frequency)	0.0 to 500.0 Hz	Y	Y	0.0	Y	Y	Y	N	
J18	(Upper limit of PID process output)	-150% to 150%; 999: Depends on setting of F15	Y	Y	999	Y	Y	Y	N	
J19	(Lower limit of PID process output)	-150% to 150%; 999: Depends on setting of F16	Y	Y	999	Y	Y	Y	N	
J21	Dew Condensation Prevention (Duty)	1% to 50%	Y	Y	1	Y	Y	Y	Y	
J22	Commercial Power Switching Sequence	0: Keep inverter operation (Stop due to alarm) 1: Automatically switch to commercial-power operation	N	Y	0	Y	N	N	Y	
J56	PID Control(Speed command filter)	0.00 to 5.00 s	Y	Y	0.10	Y	Y	Y	N	
J57	(Dancer reference position)	-100% to 0% to 100%	Y	Y	0	Y	Y	Y	N	
J58	(Detection width of dancer position deviation)	0: Disable switching PID constant 1% to 100% (Manually set value)	Y	Y	0	Y	Y	Y	N	
J59	P (Gain) 2	0.000 to 30.000 times	Y	Y	0.100	Y	Y	Y	N	
J60	I (Integral time) 2	0.0 to 3600.0 s	Y	Y	0.0	Y	Y	Y	N	
J61	D (Differential time) 2	0.00 to 600.00 s	Y	Y	0.00	Y	Y	Y	N	
J62	(PID control block selection)	0 to 3 bit 0:PID output polarity 0: Plus (add), 1: Minus (subtract) bit 1:Select compensation factor for PID output 0 = Ratio (relative to the main setting) 1 = Speed command (relative to maximum frequency)	N	Y	0	Y	Y	Y	N	
J68	Brake Signal(Brake-OFF current)	0% to 300%	Y	Y	100	Y	Y	Y	N	
J69	(Brake-OFF frequency/speed)	0.0 to 25.0 Hz	Y	Y	1.0	Y	N	N	N	
J70	(Brake-OFF timer)	0.0 to 5.0 s	Y	Y	1.0	Y	Y	Y	N	
J71	(Brake-ON frequency/speed)	0.0 to 25.0 Hz	Y	Y	1.0	Y	N	N	N	
J72	(Brake-ON timer)	0.0 to 5.0 s	Y	Y	1.0	Y	Y	Y	N	
J95	(Brake-OFF torque)	0% to 300%	Y	Y	100	N	Y	Y	N	
J96	(Speed condition selection (Braking conditions))	0 to 31 Bit 0: Criterion speed for brake-ON (0: Detected speed, 1: Reference speed) Bit 1: Reserved Bit 2: Response for brake-OFF current (0: Slow response, 1: Quick response) Bit 3: Criterion frequency for brake-ON (0: Stop frequency (F25), 1: Brake-ON frequency (J71)) Bit 4: Output condition of brake signal (0: Independent of a run command ON/OFF 1: Only when a run command is OFF)	N	Y	0		N	Y	Y	N
J97	Servo-lock (Gain)	0.00 to 10.00 times	Y*	Y	0.10	N	N	Y	N	
J98	(Completion timer)	0.000 to 1.000 s	Y	Y	0.100	N	N	Y	N	
J99	(Completion range)	0 to 9999 pulses	Y	Y	10	N	N	Y	N	

Y: Applicable / N: Not Applicable.

d codes: Application Functions 2

Code	Name	Data setting range	Change when running	Data copying	Default setting	Drive Control				Refer to Page
						V/f	Vector Control w/o PG	w/ PG	Torque control	
d01	Speed Control 1 (Speed command filter)	0.000 to 5.000 s	Y	Y	0.020	N	Y	Y	N	*11
d02	(Speed detection filter)	0.000 to 0.100 s	Y*	Y	0.005	N	Y	Y	N	
d03	P (Gain)	0.1 to 200.0 times	Y*	Y	10.0	N	Y	Y	N	
d04	I (Integral time)	0.001 to 9.999 s	Y*	Y	0.100	N	Y	Y	N	
d06	(Output filter)	0.000 to 0.100 s	Y	Y	0.002	N	Y	Y	N	
d07	(Notch filter resonance frequency)	1 to 200 Hz	Y	Y	200	N	N	Y	N	
d08	(Notch filter attenuation level)	0 to 20 dB	Y	Y	0	N	N	Y	N	
d09	Speed Control (Jogging) (Speed command filter)	0.000 to 5.000 s	Y	Y	0.020	N	Y	Y	N	
d10	(Speed detection filter)	0.000 to 0.100 s	Y*	Y	0.005	N	Y	Y	N	
d11	P (Gain)	0.1 to 200.0 times	Y*	Y	10.0	N	Y	Y	N	
d12	I (Integral time)	0.001 to 9.999 s	Y*	Y	0.100	N	Y	Y	N	
d13	(Output filter)	0.000 to 0.100 s	Y	Y	0.002	N	Y	Y	N	
d14	Feedback Input (Pulse input format)	0: Pulse train sign/Pulse train input 1: Forward rotation pulse/Reverse rotation pulse 2: A/B phase with 90 degree phase shift	N	Y	2	N	N	Y	Y	
d15	(Encoder pulse resolution)	20 to 60000 pulses	N	Y	1024	N	N	Y	Y	
d16	(Pulse count factor 1)	1 to 9999	N	Y	1	N	N	Y	Y	
d17	(Pulse count factor 2)	1 to 9999	N	Y	1	N	N	Y	Y	
d21	Speed Agreement/PG Error (Hysteresis width)	0.0% to 50.0%	Y	Y	10.0	N	Y	Y	N	
d22	(Detection timer)	0.00 to 10.00 s	Y	Y	0.50	N	Y	Y	N	
d23	PG Error Processing	0: Continue to run 1 1: Stop running with alarm 1 2: Stop running with alarm 2 3: Continue to run 2 4: Stop running with alarm 3 5: Stop running with alarm 4	N	Y	2	N	Y	Y	Y	
d24	Zero Speed Control	0: Not permit at startup 1: Permit at startup	N	Y	0	N	Y	Y	N	
d25	ASR Switching Time	0.000 to 1.000 s	Y	Y	0.000	N	Y	Y	Y	
d32	Torque Control (Speed limit 1)	0 to 110 %	Y	Y	100	N	Y	Y	Y	
d33	(Speed limit 2)	0 to 110 %	Y	Y	100	N	Y	Y	Y	
d41	Application-defined Control	0: Disable (Ordinary control) 1: Enable (Constant peripheral speed control) 2: Enable (Simultaneous synchronization, without Z phase) 3: Enable (Standby synchronization) 4: Enable (Simultaneous synchronization, with Z phase)	N	Y	0	Y	Y	Y	Y	
d51	Reserved *9	—	-	-	-	-	-	-	-	
d52	Reserved *9	—	-	-	-	-	-	-	-	
d53	Reserved *9	—	-	-	-	-	-	-	-	
d54	Reserved *9	—	-	-	-	-	-	-	-	
d55	Reserved *9	—	-	-	-	-	-	-	-	
d59	Command (Pulse Rate Input) (Pulse input format)	0: Pulse train sign/Pulse train input 1: Forward rotation pulse/Reverse rotation pulse 2: A/B phase with 90 degree phase shift	N	Y	0	Y	Y	Y	Y	
d60	(Encoder pulse resolution)	20 to 3600 pulses	N	Y	1024	N	N	Y	N	
d61	(Filter time constant)	0.000 to 5.000 s	Y	Y	0.005	Y	Y	Y	Y	
d62	(Pulse count factor 1)	1 to 9999	N	Y	1	Y	Y	Y	Y	
d63	(Pulse count factor 2)	1 to 9999	N	Y	1	Y	Y	Y	Y	
d67	Starting Mode (Auto search)	0: Disable 1: Enable (At restart after momentary power failure) 2: Enable (At restart after momentary power failure and at normal start)	N	Y	2	N	Y	N	Y	
d68	Reserved *9	—	-	-	-	-	-	-	-	
d69	Reserved *9	—	-	-	-	-	-	-	-	
d70	Speed Control Limiter	0.00 to 100.00%	Y	Y	100.00	N	N	Y	N	

*9 Factory use. Do not access these function codes.

*11 Refer to the User Manual for detailed information on these parameters.

Y: Applicable / N: Not Applicable.

Code	Name	Data setting range	Change when running	Data copying	Default setting	Drive Control				Refer to Page
						V/f	Vector Control w/o PG	w/PG	Torque control	
d71	Synchronous Operation (Main speed regulator gain)	0.00 to 1.50 times	Y	Y	1.00	N	N	Y	N	*11
d72	(APR P gain)	0.00 to 200.00 times	Y	Y	1500	N	N	Y	N	
d73	(APR positive output limiter)	20 to 200%, 999: No limiter	Y	Y	999	N	N	Y	N	
d74	(APR negative output limiter)	20 to 200%, 999: No limiter	Y	Y	999	N	N	Y	N	
d75	(Z phase alignment gain)	0.00 to 10.00 times	Y	Y	1.00	N	N	Y	N	
d76	(Synchronous offset angle)	0 to 359 degrees	Y	Y	0	N	N	Y	N	
d77	(Synchronization completion detection angle)	0 to 100 degrees	Y	Y	15	N	N	Y	N	
d78	(Excessive deviation detection range)	0 to 65535 (in units of 10 pulses)	Y	Y	65535	N	N	Y	N	
d98	Reserved *9	—	-	-	-	-	-	-	-	
d99	Reserved *9	—	-	-	-	-	-	-	-	

*9 Factory use. Do not access these function codes.

*11 Refer to the User Manual for detailed information on these parameters.

Y: Applicable / N: Not Applicable.

y codes: LINK Functions

Code	Name	Data setting range	Change when running	Data copying	Default setting	Drive Control				Refer to Page
						V/f	Vector Control w/o PG	w/ PG	Torque control	
y01	RS-485 Communication 1 (Station address)	1 to 255	N	Y	1	Y	Y	Y	Y	*11
y02	(Communications error processing)	0: Immediately trip with alarm <i>er8</i> 1: Trip with alarm <i>er8</i> after running for the period specified by timer y03 2: Retry during the period specified by timer y03. If the retry fails, trip with alarm <i>er8</i> . If it succeeds, continue to run. 3: Continue to run	Y	Y	0	Y	Y	Y	Y	
y03	(Timer)	0.0 to 60.0 s	Y	Y	2.0	Y	Y	Y	Y	
y04	(Baud rate)	0: 2400 bps 1: 4800 bps 2: 9600 bps 3: 19200 bps 4: 38400 bps	Y	Y	3	Y	Y	Y	Y	
y05	(Data length)	0: 8 bits 1: 7 bits	Y	Y	0	Y	Y	Y	Y	
y06	(Parity check)	0: None (2 stop bits) 1: Even parity (1 stop bit) 2: Odd parity (1 stop bit) 3: None (1 stop bit)	Y	Y	0	Y	Y	Y	Y	
y07	(Stop bits)	0: 2 bits 1: 1 bit	Y	Y	0	Y	Y	Y	Y	
y08	RS-485 Communication 1(No-response error detection time)	0: No detection; 1 to 60 s	Y	Y	0	Y	Y	Y	Y	
y09	(Response interval)	0.00 to 1.00 s	Y	Y	0.01	Y	Y	Y	Y	
y10	(Protocol selection)	0: Modbus RTU protocol 1: TECO Link Software protocol (SX protocol)	Y	Y	1	Y	Y	Y	Y	
y11	RS-485 Communication 2 (Station address)	1 to 255	N	Y	1	Y	Y	Y	Y	
y12	(Communications error processing)	0: Immediately trip with alarm <i>erp</i> 1: Trip with alarm <i>erp</i> after running for the period specified by timer y13 2: Retry during the period specified by timer y13. If the retry fails, trip with alarm <i>erp</i> . If it succeeds, continue to run. 3: Continue to run	Y	Y	0	Y	Y	Y	Y	
y13	(Timer)	0.0 to 60.0 s	Y	Y	2.0	Y	Y	Y	Y	
y14	(Baud rate)	0: 2400 bps, 1: 4800 bps, 2: 9600 bps 3: 19200 bps, 4: 38400 bps	Y	Y	3	Y	Y	Y	Y	
y15	(Data length)	0: 8 bits 1: 7 bits	Y	Y	0	Y	Y	Y	Y	
y16	(Parity check)	0: None (2 stop bits) 1: Even parity (1 stop bit) 2: Odd parity (1 stop bit) 3: None (1 stop bit)	Y	Y	0	Y	Y	Y	Y	
y17	(Stop bits)	0: 2 bits 1: 1 bit	Y	Y	0	Y	Y	Y	Y	
y18	(No-response error detection time)	0: No detection; 1 to 60 s	Y	Y	0	Y	Y	Y	Y	
y19	(Response interval)	0.00 to 1.00 s	Y	Y	0.01	Y	Y	Y	Y	
y20	(Protocol selection)	0: Modbus RTU protocol	Y	Y	0	Y	Y	Y	Y	
y97	Communication Data Storage Selection	0: Save into nonvolatile storage (Rewritable times limited) 1: Write into temporary storage (Rewritable times unlimited) 2: Save all data from temporary storage to nonvolatile one (After saving data, the y97 data automatically returns to "1.")	Y	Y	0	Y	Y	Y	Y	
y98	Bus Link Function(Mode selection)	Frequency command Run command 0: Follow H30 data Follow H30 data 1: Via fieldbus option Follow H30 data 2: Follow H30 data Via fieldbus option 3: Via fieldbus option Via fieldbus option	Y	Y	0	Y	Y	Y	Y	
y99	Loader Link Function (Mode selection)	Frequency command Run command 0: Follow H30 and y98 data Follow H30 and y98 data 1: Via RS-485 link Follow H30 and y98 data (TECO Link Software) 2: Follow H30 and y98 data Via RS-485 link (TECO Link Software) 3: Via RS-485 link Via RS-485 link (TECO Link Software)	Y	N	0	Y	Y	Y	Y	

*11 Refer to the User Manual for detailed information on these parameters.

Y: Applicable / N: Not Applicable.

Inverter capacity HP	Auto-restart after momentary power failure H13	Inverter capacity HP	Auto-restart after momentary power failure H13
0.5	0.5	100	1.5
1		125	
2		150	
3		200	2.0
5		250	
7		300	2.5
10		350	
15	450		
20	1.0	500	4.0
25		600	
30		700	5.0
40		800	
50		900	
60		1000	
75	1.5		

Inverter capacity HP	Auto-restart after momentary power failure H13	Inverter capacity HP	Auto-restart after momentary power failure H13
0.5	0.5	100	1.5
1		125	
2		150	
3		200	2.0
5		250	
7		300	2.5
10		350	
15	450		
20	1.0	500	4.0
25		600	
30		700	5.0
40		800	
50		900	
60		1000	
75	1.5		

Table B Motor Parameters

When the "HP rating motors" is selected with P99/A39 (data = 1)

Three-phase 230 V series (EQ7-2_ _ _ -C)

Motor capacity (HP)	Nominal applied motor (HP)	Rated current (A)	No-load current (A)	%R1	%X	Rated slip frequency (Hz)	Iron loss factor 1 (%)	Magnetic saturation factor 1 (%)	Magnetic saturation factor 2 (%)	Magnetic saturation factor 3 (%)	Magnetic saturation factor 4 (%)	Magnetic saturation factor 5 (%)	Magnetic saturation extension factor "a" (%)	Magnetic saturation extension factor "b" (%)	Magnetic saturation extension factor "c" (%)	Torque current under vector control (A)	Starting mode (Auto search delay time 2)
	P02	P03	P06	P07	P08	P12	P13	P16	P17	P18	P19	P20	P21	P22	P23	P55	H46
0.01 to 0.11	0.1	0.44	0.40	13.79	11.75	2.50	14.00	93.8	87.5	75.0	62.5	50.0	106.3	112.5	118.8	0.21	
0.12 to 0.24	0.12	0.68	0.55	12.96	12.67	2.50	14.00	93.3	86.1	74.4	63.6	50.7	108.8	118.7	129.6	0.27	
0.25 to 0.49	0.25	1.40	1.12	11.02	13.84	2.50	12.60	89.7	81.9	69.9	54.5	43.3	111.0	129.3	148.4	0.53	0.5
0.50 to 0.99	0.5	2.00	1.22	6.15	8.80	2.50	9.88	88.7	81.3	67.0	55.2	43.8	112.1	126.5	144.3	1.09	
1.00 to 1.99	1	3.00	1.54	3.96	8.86	2.50	7.40	88.3	77.7	62.6	51.8	41.1	112.4	129.2	148.4	2.21	
2.00 to 2.99	2	5.80	2.80	4.29	7.74	2.50	5.85	92.1	82.8	71.1	58.1	46.2	111.4	126.1	143.9	4.43	
3.00 to 4.99	3	7.90	3.57	3.15	20.81	1.17	5.91	85.1	74.6	61.7	50.3	39.8	115.7	133.5	150.6	6.64	0.6
5.00 to 7.49	5	12.6	4.78	3.34	23.57	1.50	5.24	86.0	76.9	61.3	49.5	39.1	115.6	133.2	154.1	11.07	0.8
7.50 to 9.99	7.5	18.6	6.23	2.65	28.91	1.17	4.75	88.6	79.2	64.9	52.7	41.8	114.3	133.1	155.6	16.60	1.0
10.00 to 14.99	10	25.3	8.75	2.43	30.76	1.17	4.03	87.7	80.0	67.1	56.1	45.6	111.7	128.4	149.2	22.15	1.2
15.00 to 19.99	15	37.3	12.7	2.07	29.13	1.00	3.92	91.3	83.3	69.9	58.0	47.0	114.1	130.2	147.9	33.22	1.3
20.00 to 24.99	20	49.1	9.20	2.09	29.53	1.00	3.32	90.5	83.5	72.1	60.7	49.5	109.0	121.3	137.8	44.30	
25.00 to 29.99	25	60.0	16.70	1.75	31.49	1.00	3.34	90.7	83.0	70.7	59.9	48.7	112.1	127.9	147.5	55.37	2.0
30.00 to 39.99	30	72.4	19.80	1.90	32.55	1.00	3.28	89.7	81.3	68.9	59.1	48.4	114.1	130.2	151.8	66.45	
40.00 to 49.99	40	91.0	13.60	1.62	25.32	0.47	3.10	90.2	81.6	68.7	57.2	45.8	114.8	132.3	153.9	88.60	2.3
50.00 to 59.99	50	115.0	18.70	1.92	24.87	0.58	2.30	88.7	78.9	65.4	54.2	43.4	112.2	126.4	143.6	110.7	
37.00 to 44.99	60	137.0	20.80	1.29	26.99	0.35	2.18	89.0	79.7	66.8	55.4	44.4	112.3	126.0	141.8	132.9	2.5
75.00 to 99.99	75	174.0	28.60	1.37	27.09	0.35	2.45	89.2	79.3	64.7	53.6	43.1	117.2	136.2	157.8	166.1	2.6
100.00 to 124.9	100	226.0	37.40	1.08	23.80	0.23	2.33	88.1	78.0	64.3	54.2	42.9	114.9	129.8	144.6	221.5	2.8
125.00 to 149.9	125	268.0	29.80	1.05	22.90	0.35	2.31	88.8	79.0	65.0	54.0	44.0	115.0	130.0	145.0	276.9	3.2
150.0 or above	150	337.0	90.40	0.96	21.61	0.39	1.73	90.5	82.6	70.7	58.7	47.8	112.2	126.1	142.4	332.2	3.5

Table B Motor Parameters (Continued)

Three-phase 460 V series (EQ7-4 _ _ _ -C)

Motor capacity (HP)	Nominal applied motor (HP)	Rated current (A)	No-load current (A)	%R1	%X	Rated slip frequency (Hz)	Iron loss factor 1 (%)	Magnetic saturation factor 1 (%)	Magnetic saturation factor 2 (%)	Magnetic saturation factor 3 (%)	Magnetic saturation factor 4 (%)	Magnetic saturation factor 5 (%)	Magnetic saturation extension factor β_{st} (%)	Magnetic saturation extension factor β_{sc} (%)	Magnetic saturation extension factor β_{sc} (%)	Torque current under vector control (A)	Starting mode (Auto search delay time 2)
P02	P03	P06	P07	P08	P12	P13	P16	P17	P18	P19	P20	P21	P22	P23	P24	P55	H46
0.07 to 0.11	0.1	0.22	13.79	11.75	2.50	14.00	93.8	87.5	75.0	62.5	50.0	106.3	112.5	118.8	118.8	0.10	
0.12 to 0.24	0.12	0.34	12.96	12.67	2.50	14.00	93.3	86.1	74.4	63.6	50.7	108.8	118.7	129.6	129.6	0.13	
0.25 to 0.49	0.25	0.70	11.02	13.84	2.50	12.60	89.7	81.9	66.9	54.5	43.3	111.0	129.3	148.4	148.4	0.27	0.5
0.50 to 0.99	0.5	1.00	6.15	8.80	2.50	9.88	88.7	81.3	67.0	55.2	43.8	112.1	126.5	144.3	144.3	0.55	
1.00 to 1.99	1	1.50	3.96	8.86	2.50	7.40	88.3	77.7	62.6	51.8	41.1	112.4	129.2	148.4	148.4	1.11	
2.00 to 2.99	2	2.90	4.29	7.74	2.50	5.85	92.1	82.8	71.1	58.1	46.2	111.4	126.1	143.9	143.9	2.21	
3.00 to 4.99	3	4.00	1.79	3.15	1.17	5.91	85.1	74.6	61.7	50.3	39.8	115.7	133.5	150.6	150.6	3.32	0.6
5.00 to 7.49	5	6.30	2.39	3.34	1.50	5.24	86.0	76.9	61.3	49.5	39.1	115.6	133.2	154.1	154.1	5.54	0.8
7.50 to 9.99	7.5	9.30	3.12	2.85	1.17	4.75	88.6	79.2	64.9	52.7	41.8	114.3	133.1	155.6	155.6	8.30	1.0
10.00 to 14.99	10	12.7	4.37	2.43	1.17	4.03	87.7	80.0	67.1	56.1	45.6	111.7	128.4	149.2	149.2	11.07	1.2
15.00 to 19.99	15	18.7	6.36	2.07	1.00	3.92	91.3	83.3	69.9	58.0	47.0	114.1	130.2	147.9	147.9	16.61	1.3
20.00 to 24.99	20	24.6	8.60	2.09	1.00	3.32	90.5	83.5	72.1	60.7	49.5	109.0	121.3	137.8	137.8	22.15	
25.00 to 29.99	25	30.0	8.33	1.75	1.00	3.34	90.7	83.0	70.7	59.9	48.7	112.1	127.9	147.5	147.5	27.69	2.0
30.00 to 39.99	30	36.2	9.88	1.90	32.55	1.00	89.7	81.3	68.9	59.1	48.4	114.1	130.2	151.8	151.8	33.22	
40.00 to 49.99	40	45.5	1.82	25.32	0.47	3.10	90.2	81.6	68.7	57.2	45.8	114.8	132.3	153.9	153.9	44.30	2.3
50.00 to 59.99	50	57.5	9.33	1.92	24.87	1.00	88.7	78.9	65.4	54.2	43.4	112.2	126.4	143.6	143.6	55.37	2.5
60.00 to 74.99	60	68.7	10.4	1.29	26.99	0.35	89.0	79.7	66.8	55.4	44.4	112.3	126.0	141.8	141.8	66.45	
75.00 to 99.99	75	86.9	14.3	1.37	27.09	0.35	89.2	79.3	64.7	53.6	43.1	117.2	136.2	157.8	157.8	83.06	2.6
100.0 to 124.9	100	113.0	18.7	1.08	23.80	0.23	88.1	78.0	64.3	54.2	42.9	114.9	129.8	144.6	144.6	110.7	2.8
125.0 to 149.9	125	134.0	14.9	1.05	22.90	0.35	88.8	79.0	65.0	54.0	44.0	115.0	130.0	145.0	145.0	138.4	3.2
150.0 to 174.9	150	169.0	45.2	0.96	21.61	0.39	90.5	82.6	70.7	58.7	47.8	112.2	126.1	142.4	142.4	166.1	3.5
175.0 to 199.9	175	169.0	45.2	0.96	21.61	0.39	90.3	81.9	69.8	57.8	46.6	112.9	127.6	144.8	144.8	183.0	4.1
200.0 to 249.9	200	231.0	81.8	0.72	20.84	0.23	92.2	84.8	71.1	58.6	46.9	114.6	130.5	148.0	148.0	209.2	4.5
250.0 to 299.9	250	272.0	41.1	0.71	18.72	0.35	91.9	85.5	72.3	60.0	47.6	109.8	122.7	136.4	136.4	261.5	4.7
300.0 to 324.9	300	323.0	45.1	0.53	18.44	0.23	93.1	86.1	72.9	60.8	48.6	108.7	118.8	130.9	130.9	313.8	
325.0 to 349.9	325	323.0	45.1	0.53	18.44	0.23	92.2	84.9	72.7	60.5	48.6	109.9	122.2	137.8	137.8	339.9	5.0
350.0 to 399.9	350	375.0	68.3	0.99	19.24	0.46	92.2	84.9	72.7	60.5	48.6	109.9	122.2	137.8	137.8	366.1	5.5
400.0 to 449.9	400	429.0	80.7	1.11	18.92	0.46	92.2	84.9	72.7	60.5	48.6	109.9	122.2	137.8	137.8	418.4	5.6
450.0 to 499.9	450	481.0	85.5	0.95	19.01	0.48	92.2	84.9	72.7	60.5	48.6	109.9	122.2	137.8	137.8	470.7	7.5
500.0 to 599.9	500	534.0	99.2	1.05	18.39	0.45	92.2	84.9	72.7	60.5	48.6	109.9	122.2	137.8	137.8	523.0	
600.0 to 699.9	600	638.0	140.0	0.85	18.38	0.39	92.2	84.8	71.1	58.6	46.9	114.6	130.5	148.0	148.0	627.6	9.8
700.0 to 749.9	700	756.0	164.0	1.02	21.92	0.70	92.2	84.8	71.1	58.6	46.9	114.6	130.5	148.0	148.0	732.1	
750.0 to 799.9	750	806.0	144.0	1.15	24.53	0.61	92.2	84.8	71.1	58.6	46.9	114.6	130.5	148.0	148.0	784.4	
800.0 to 849.9	800	870.0	209.0	1.17	21.69	0.45	92.2	84.8	71.1	58.6	46.9	114.6	130.5	148.0	148.0	836.7	
850.0 to 899.9	850	923.0	172.0	1.34	25.44	0.60	92.2	84.8	71.1	58.6	46.9	114.6	130.5	148.0	148.0	889.0	10.5
900.0 or above	900	994.0	239.0	1.40	23.79	0.55	92.2	84.8	71.1	58.6	46.9	114.6	130.5	148.0	148.0	941.3	

4.2 Details of Function Codes

This section provides the details of the function codes. The descriptions are, in principle, arranged in the order of function code groups and in numerical order. However, highly relevant function codes are collectively described where one of them first appears.

4.2.1 Fundamental Functions

F00 Data Protection

F00 specifies whether to protect function code data (except F00) and digital reference data (such as frequency command and PID command) from accidentally getting changed by pressing the \odot / \ominus keys on the keypad.

Data for F00	Changing function code data		Changing digital reference data with the \odot / \ominus keys
	From the keypad	Via communications link	
0	Allowed	Allowed	Allowed
1	Not allowed *	Allowed	Allowed
2	Allowed	Allowed	Not allowed
3	Not allowed *	Allowed	Not allowed

*Only F00 data can be modified with the keypad, while all other function codes cannot.

To change F00 data, simultaneously press " $\text{STOP} + \odot$ " (from 0 to 1) or " $\text{STOP} + \ominus$ " (from 1 to 0) keys.

For similar purposes, **WE-KP**, a signal that enables editing of function code data from the keypad is provided as a terminal command for digital input terminals. (Refer to the descriptions of E01 through E07, data = 19)

The relationship between the terminal command **WE-KP** and F00 data are as shown below.

WE-KP	Changing function code data	
	From the keypad	Via communications link
OFF	Not allowed	Allowed
ON	Follow the F00 setting	

Note

- If you mistakenly assign the terminal command **WE-KP**, you can no longer edit or modify function code data. To undo this temporarily turn this **WE-KP**-assigned terminal ON and reassign the **WE-KP** to a correct command.

- WE-KP** is only a signal that allows changing function code data, so it does not protect the frequency settings or PID command specified by the \odot and \ominus keys.

Tip

Even when F00 = 1 or 3, function code data can be changed via the communications link.

F01 Frequency Command 1 (Related parameters listed here)

F18 (Bias, Frequency command 1)	C30 (Frequency Command 2)
C31 to C35 (Analog Input Adjustment for [12])	C36 to C39 (Analog Input Adjustment for [C1])
C41 to C45 (Analog Input Adjustment for [V2])	C50 (Bias (Frequency command 1), Bias base point)
H61 (UP/DOWN Control, Initial frequency setting)	d59, d61 to d63 (Command (Pulse Rate Input))

F01 or C30 sets a command source that specifies reference frequency 1 or reference frequency 2.

Data for F01, C30	Function	Refer to:
0	Enable \odot / \ominus keys on the keypad.	[1]
1	Enable the voltage input to terminal [12] (0 to ± 10 VDC, maximum frequency obtained at ± 10 VDC).	[2]
2	Enable the current input to terminal [C1] (+4 to +20 mA DC, maximum frequency obtained at +20 mA DC). (SW5 on the control PCB should be turned to the C1 side (factory default).)	
3	Enable the sum of voltage (0 to ± 10 VDC) and current inputs (+4 to +20 mA DC) given to terminals [12] and [C1], respectively. See the two items listed above for the setting range and the value required for maximum frequencies. (SW5 on the control PCB should be turned to the C1 side (factory default).) Note: If the sum exceeds the maximum frequency (F03), the maximum frequency will apply.	
5	Enable the voltage input to terminal [V2] (-10 to ± 10 VDC, maximum frequency obtained at ± 10 VDC). (SW5 on the control circuit board should be turned to the V2 position (factory default).)	[3]
7	Enable UP and DOWN commands assigned to the digital input terminals. The UP command (any of E01 to E07 = 17) and DOWN command (any of E01 to E07 = 18) should be assigned to any of digital input terminals [X1] to [X7]. For details, refer to the descriptions of E01 through E07.	
8	Enable \odot / \ominus keys on the keypad (balanceless-bumpless switching available).	[1]
11	Enable a digital input interface card (option). (For details, refer to the Digital Input Interface Card Instruction Manual.)	—
12	Enable the "Pulse train input" PIN command assigned to digital input terminal [X7] (E07 = 48), or a PG interface card (option).	[4]

Configuring a reference frequency

[1] Using \odot and \ominus keys (F01 = 0 (factory default) or 8)

- (1) Set function code F01 at "0" or "8" (\odot / \ominus keys on keypad). This cannot be done when the keypad is in Programming or Alarm mode. To enable frequency setting using the \odot and \ominus keys, first place the keypad in Running mode.
- (2) Press the \odot or \ominus key. The 7-segment LED monitor displays the reference frequency and the LCD monitor displays the related information including the operation guide, as shown below.

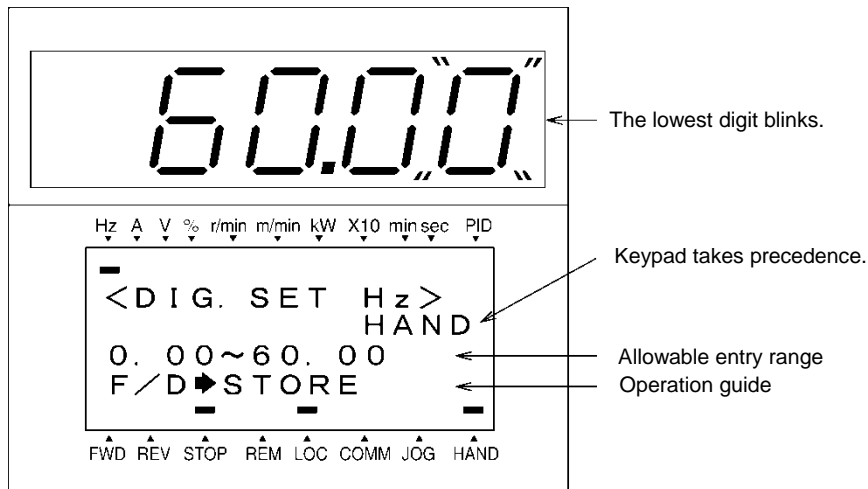

Example of Reference Frequency Configuration Screen

- (3) To change the reference frequency, press the \odot or \ominus key again. To save the new setting into the inverter's memory, press the ALM key (when E64 = 1 (factory default)). When the power is turned ON next time, the new setting will be used as an initial reference frequency.

In addition to saving with the ALM key described above, "Automatic saving when the main power is turned OFF" is also possible (when E64 = 0).



- When you start accessing the reference frequency or any other parameter with the \odot and \ominus keys, the least significant digit on the display blinks and starts changing. As you are holding down the key, blinking gradually moves to the upper digit places and the upper digits becomes changeable.
- Pressing the ALM key moves the changeable digit place (blinking), making it easy to change upper digits.
- Setting function code C30 at "0" (Enable \odot / \ominus keys on the keypad) and selecting frequency command 2 as a frequency command source makes it possible to access the reference frequency in the same manner using the \odot and \ominus keys.
- If you have set function code F01 at "0" (\odot / \ominus keys on keypad) but have selected a frequency command source other than frequency 1 (i.e., frequency 2, via communications link, or as a multi-frequency), then using the \odot or \ominus key cannot change the frequency command even if the keypad is in Running mode. Pressing either of these keys just displays the currently selected frequency command.
- Setting function code F01 at "8" (\odot / \ominus keys on keypad) enables the balanceless-bumpless switching. When the frequency command source is switched to the keypad from any other source, the inverter inherits the current frequency that has applied before switching, providing smooth switching and shockless running.
- When the frequency command source is other than the digital reference setting, the LCD monitor displays the following.

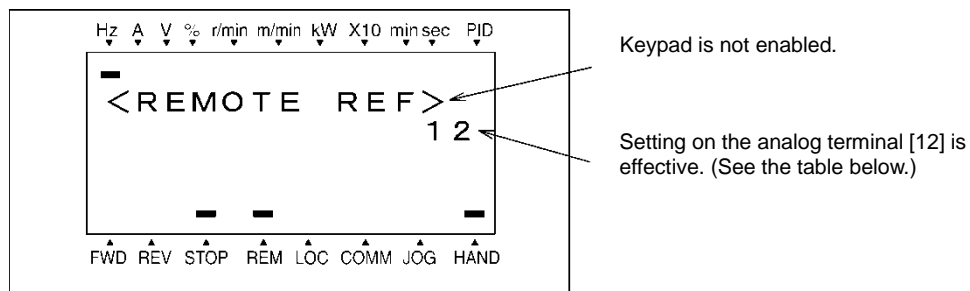

The table below lists the available command sources and their symbols.

Available Command Sources

Symbol	Command source	Symbol	Command source	Symbol	Command source
HAND	Keypad	MULTI	Multi-frequency	PID-HAND	PID keypad command
12	Terminal [12]			PID-P1	PID command 1 (Analog command)
C1	Terminal [C1]	RS485-1	RS-485 (Port 1) *1	PID-P2	PID command 2 (Analog command)
12 + C1	Terminal [12] + Terminal [C1]	RS485-2	RS-485 (Port 2) *2	PID-U/D	PID UP/DOWN command
V2	Terminal [V2]	BUS	Bus option	PID_LINK	PID communications command
U/D	UP/DOWN control	LOADER	Inverter support software "TECO Link Software"	PID+MULTI	PID multi-frequency command

*1 COM port 1 which refers to the RJ-45 connector on the inverter.

*2 COM port 2 which is on the inverter's terminal block.

[2] Using analog input (F01 = 1 to 3, or 5)

When any analog input (voltage input to terminals [12] and [V2], or current input to terminal [C1]) is selected by F01, it is possible to arbitrarily specify the reference frequency by multiplying the gain and adding the bias. The polarity can be selected and the filter time constant and offset can be adjusted.

Adjustable elements of frequency command 1

Data for F01	Input terminal	Input range	Bias		Gain		Polarity	Filter time constant	Offset
			Bias	Base point	Gain	Base point			
1	[12]	0 to +10 V, -10 to +10V	F18	C50	C32	C34	C35	C33	C31
2	[C1]	4 to 20 mA	F18	C50	C37	C39	-	C38	C36
3	[12] + [C1] (Sum of the two values)	0 to +10 V, -10 to +10 V	F18	C50	C32	C34	C35	C33	C31
		4 to 20 mA	F18	C50	C37	C39	-	C38	C36
5	[V2]	0 to +10 V, -10 to +10 V	F18	C50	C42	C44	C45	C43	C41

■ Offset (C31, C36, C41)

C31, C36 or C41 specifies an offset for analog input voltage or current. The offset also applies to signals from external devices (PLCs, Feedback Sensors, Signal Converters, etc...).

■ Filter time constant (C33, C38, C43)

C33, C38, or C43 specifies a filter time constant for analog input voltage or current. Choose an appropriate value for the time constant taking into account the response speed of the machinery system since a large time constant slows down the response. When the input voltage fluctuates due to noise, specify a larger time constant.

■ Polarity (C35, C45)

C35 or C45 specifies the input range for analog input voltage.

Data for C35/C45	Terminal input specifications
0	-10 to +10 VDC
1	0 to +10 VDC (negative value of voltage is regarded as 0 V)

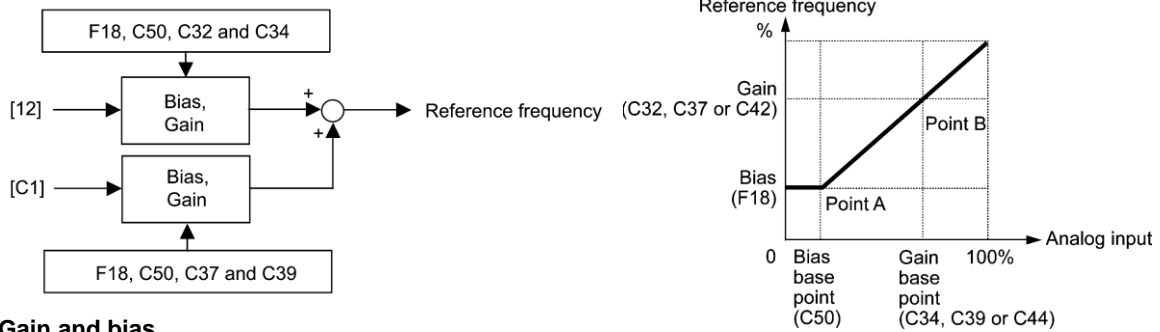

■ **Gain and bias**

Note If F01 = 3 (the sum of [12] + [C1] is enabled), the bias and gain are independently applied to each of the voltage and current inputs given to terminals [12] and [C1], and the sum of the two values is applied as the reference frequency.

In the case of unipolar input (terminal [12] with C35 = 1, terminal [C1], terminal [V2] with C45 = 1)

As shown in the graph above, the relationship between the analog input and the reference frequency specified by frequency command 1 can arbitrarily be determined by points "A" and "B." Point "A" is defined by the combination of the bias (F18) and its base point (C50); Point "B," by the combination of the gain (C32, C37 or C42) and its base point (C34, C39 or C44).

The combination of C32 and C34 applies to terminal [12], that of C37 and C39, to [C1] (C1 function), and that of C42 and C44, to [C1] (V2 function).

Configure the bias (F18) and gain (C32, C37 or C42), assuming the maximum frequency as 100%, and the bias base point (C50) and gain base point (C34, C39 or C44), assuming the full scale (10 VDC or 20 mA DC) of analog input as 100%.

- The analog input less than the bias base point (C50) is limited by the bias value (F18).
- Specifying that the data of the bias base point (C50) is equal to or greater than that of each gain base point (C34, C39 or C44) will be interpreted as invalid, so the inverter will reset the reference frequency to 0 Hz.

Example: Setting the bias, gain and their base points when the reference frequency 0 to 60 Hz follows the analog input of 1 to 5 VDC to terminal [12] (in frequency command 1).

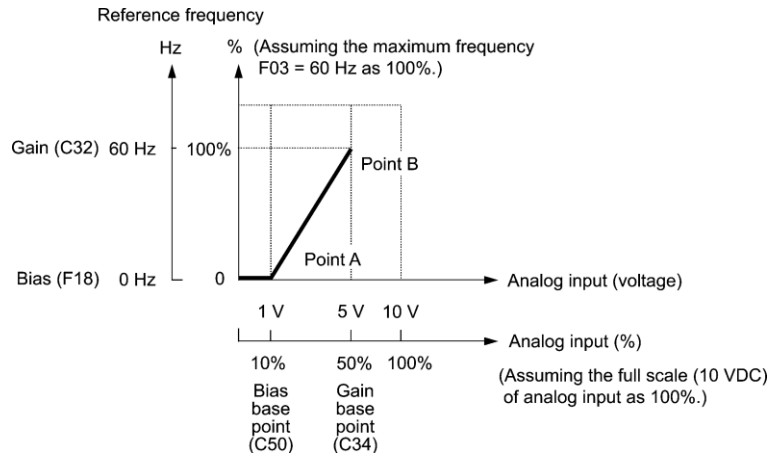

(Point A)

To set the reference frequency to 0 Hz for an analog input being at 1 V, set the bias to 0% (F18 = 0). Since 1 V is the bias base point and it is equal to 10% of 10 V (full scale of terminal [12]), set the bias base point to 10% (C50 = 10).

(Point B)

To make the maximum frequency equal to the reference frequency for an analog input being at 5 V, set the gain to 100% (C32 = 100). Since 5 V is the gain base point and it is equal to 50% of 10 V (full scale of terminal [12]), set the gain base point to 50% (C34 = 50).

In the case of bipolar input (terminal [12] with C35 = 0, terminal [V2] with C45 = 0)

Setting C35 and C45 data to "0" enables terminal [12] and [V2] to be used for bipolar input (-10 V to +10 V) respectively.

When both F18 (Bias) and C50 (Bias base point) are set to "0," the negative and positive voltage inputs produce reference frequencies symmetric about the origin point as shown below.

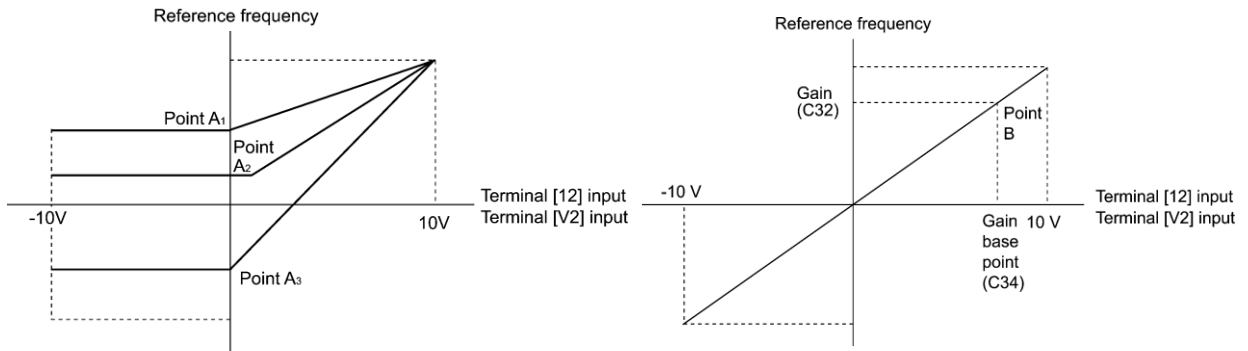

Note Configuring F18 (Bias) and C50 (Bias base point) to specify an arbitrary value (Points A₁, A₂, and A₃) gives the bias as shown above.

Note A reference frequency can be specified not only with the frequency (Hz) but also with other menu items, depending on the setting of function code E48 (= 3 to 5, or 7).

[3] Using digital input signals UP/DOWN (F01 = 7)

When the **UP/DOWN** control is selected for frequency setting with a run command ON, turning the terminal command **UP** or **DOWN** ON causes the output frequency to increase or decrease, respectively, within the range from 0 Hz to the maximum frequency as listed below.

To enable the **UP/DOWN** control for frequency setting, it is necessary to set F01 data to "7" and assign the **UP** and **DOWN** commands to any of digital input terminals [X1] to [X7], [FWD] and [REV] with any of E01 to E07 (data = 17 or 18).

UP	DOWN	Function
Data = 17	Data = 18	
OFF	OFF	Keep the current output frequency.
ON	OFF	Increase the output frequency with the acceleration time currently specified.
OFF	ON	Decrease the output frequency with the deceleration time currently specified.
ON	ON	Keep the current output frequency.

■ **Specifying the initial value for the *UP/DOWN* control**

Specify the initial value to start the *UP/DOWN* control.

Data for H61	Initial value to start the <i>UP/DOWN</i> control
0	Mode fixing the value at "0": The inverter automatically clears the value to "0" when restarted (including powered ON). Speed up by the <i>UP</i> command.
1	Mode holding the final output frequency in the previous <i>UP/DOWN</i> control: The inverter internally holds the last output frequency set by the <i>UP/DOWN</i> control and applies the held frequency at the next restart (including powering ON).

Note At the time of restart, if an *UP* or *DOWN* terminal command is entered before the internal frequency reaches the output frequency saved in the memory, the inverter saves the current output frequency into the memory and starts the *UP/DOWN* control with the new frequency. Pressing one of these keys overwrites the frequency held in the inverter.

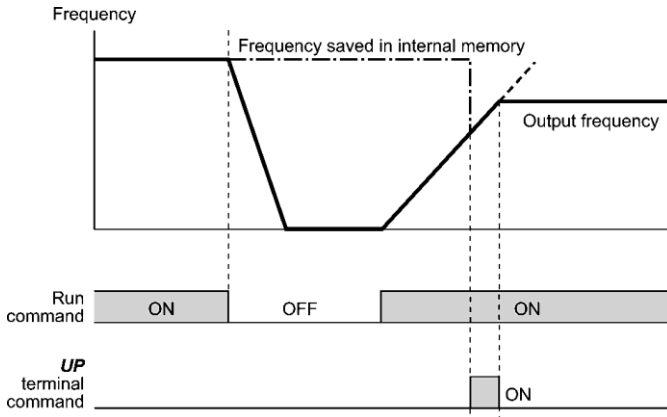

Initial frequency for the *UP/DOWN* control when the frequency command source is switched

When the frequency command source is switched to the *UP/DOWN* control from other sources, the initial frequency for the *UP/DOWN* control is as listed below:

Frequency command source	Switching command	Initial frequency for <i>UP/DOWN</i> control	
		H61 = 0	H61 = 1
Other than <i>UP/DOWN</i> (F01, C30)	Select frequency command 2/1 (<i>Hz2/Hz1</i>)	Reference frequency given by the frequency command source used just before switching	
PID control	Cancel PID control (<i>Hz/PID</i>)	Reference frequency given by PID control (PID controller output)	
Multi-frequency	Select multi-frequency (<i>SS1, SS2, SS4</i> and <i>SS8</i>)	Reference frequency given by the frequency command source used just before switching	Reference frequency at the time of previous <i>UP/DOWN</i> control
Communications link	Enable communications link via RS-485 or fieldbus (<i>LE</i>)		

[4] Using pulse train input (F01 = 12)

The EQ7 can accommodate different types of pulse train inputs. Select the type of signal (d59) and scaling (d62, d63) as described here.

■ Selecting the pulse train input format (d59)

A pulse train in the format selected by the function code d59 can give a frequency command to the inverter. Three types of formats are available; the pulse train sign/pulse train input, the forward rotation pulse/reverse rotation pulse, and the A and B phases with 90 degree phase difference. If no optional PG interface card is mounted, the inverter ignores the setting of the function code d59 and accepts only the pulse train sign/pulse train input.

The table below lists pulse train formats and their operations.

Pulse train input format selected by d59	Operation overview
0: Pulse train sign/ Pulse train input	Frequency/speed command according to the pulse train rate is given to the inverter. The pulse train sign specifies the polarity of the frequency/speed command. <ul style="list-style-type: none"> For the inverter without an optional PG interface card Pulse train input: PIN assigned to the digital terminal [X7] (data = 48) Pulse train sign: SIGN assigned to a digital terminal other than [X7] (data = 49) If no SIGN is assigned, polarity of any pulse train input is positive.
1: Forward rotation pulse/Reverse rotation pulse	Frequency/speed command according to the pulse train rate is given to the inverter. The forward rotation pulse gives a frequency/speed command with positive polarity, and a reverse rotation pulse, with negative polarity.
2: A and B phases with 90 degree phase difference	Pulse trains generated by A and B phases with 90 degree phase difference give a frequency/speed command based on their pulse rate and the phase difference to an inverter.

For details of operations using the optional PG interface card, refer to the Instruction Manual for it.

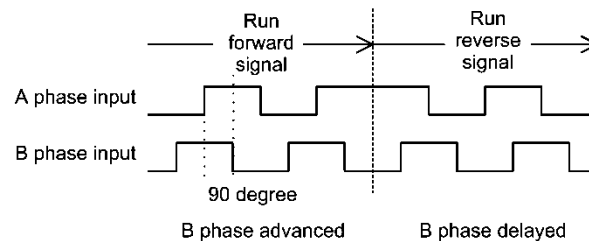
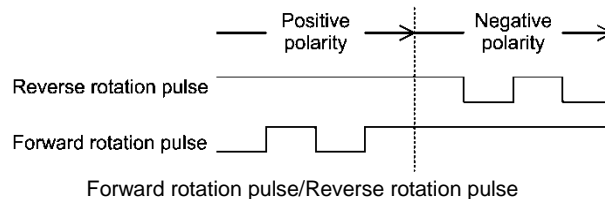
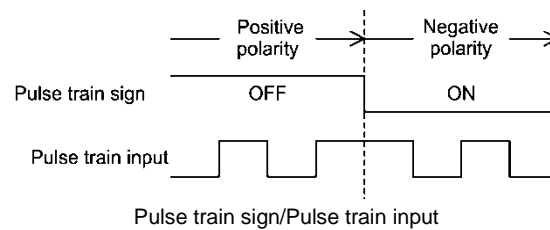

■ **Pulse count factor 1 (d62), Pulse count factor 2 (d63)**

For the pulse train input, function codes d62 (Command (Pulse rate input), (Pulse count factor 1)) and d63 (Command (Pulse rate input), (Pulse count factor 2)) define the relationship between the input pulse rate and the frequency command (reference).

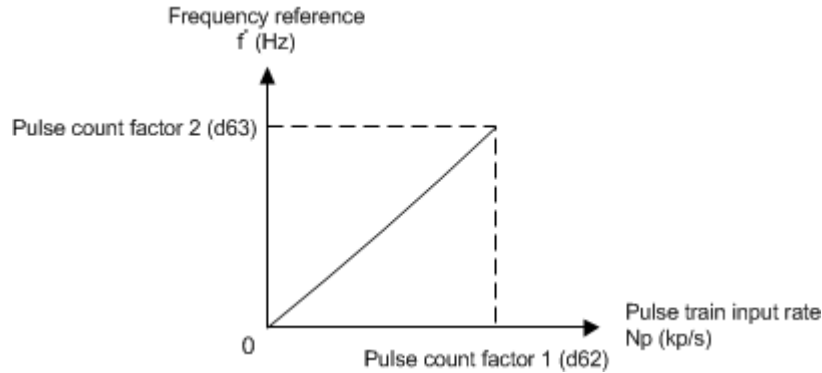

Relationship between the Pulse Train Input Rate and Frequency Command (Reference)

As shown in the figure above, enter the pulse train input rate into function code d62 (Command (Pulse rate input), (Pulse count factor 1)), and enter the frequency reference defined by d62 into d63 (Command (Pulse rate input), (Pulse count factor 2)). The relationship between the pulse train input rate (kp/s) inputted to the **PIN** terminal and the frequency reference f^* (Hz) (or speed command) is given by the expression below.

$$f^* \text{ (Hz)} = N_p \text{ (kp/s)} \times \frac{\text{Pulse count factor 2 (d63)}}{\text{Pulse count factor 1 (d62)}}$$

f^* (Hz) : Frequency reference

N_p (kp/s) : Input pulse rate

In the case of A and B phases with 90 degree phase difference, note that the pulse train rate is not the one 4-multiplied.

The pulse train sign, forward/reverse rotation pulse, and A/B phase difference define the polarity of the pulse train input. Combination of the polarity of the pulse train input and the **FWD/REV** command determines the rotational direction of the motor. The table below shows the relationship between the polarity of the pulse train input and the motor rotational direction.

Pulse Train Polarity	Run command	Motor rotational direction
Positive (+)	FWD (Run forward command)	Forward
Positive (+)	REV (Run reverse command)	Reverse
Negative (-)	FWD (Run forward command)	Reverse
Negative (-)	REV (Run reverse command)	Forward

 **Mounting an optional PG interface card automatically switches the pulse train input source to the card and disables the input from the terminal [X7].**

■ **Filter time constant (d61)**

d61 specifies a filter time constant for pulse train input. Choose an appropriate value for the time constant taking into account the response speed of the machinery system since a large time constant slows down the response. When the reference frequency fluctuates due to small number of pulses, specify a larger time constant.

Switching frequency command

Using the terminal command **H_{z2}/H_{z1}** assigned to one of the digital input terminals switches between frequency command 1 (F01) and frequency command 2 (C30).

 For details about **H_{z2}/H_{z1}**, refer to E01 to E07 (data = 11).

Terminal command H_{z2}/H_{z1}	Frequency command source
OFF	Follow F01 (Frequency command 1)
ON	Follow C30 (Frequency command 2)

F02 selects the source that specifies a run command.

Data for F02	Run Command	Description
0	Keypad	Enables the FWD , REV , and STOP keys to run the motor in the forward and reverse directions, and stop the motor.
1	Terminal command FWD or REV	Enables input terminal commands FWD and REV to run the motor in the forward and reverse directions, and stop the motor.
2	Keypad (Forward rotation)	Enables the FWD and STOP keys to run the motor in the forward direction and stop it. Running the motor in the reverse direction is not possible.
3	Keypad (Reverse rotation)	Enables the REV and STOP keys to run the motor in the reverse direction and stop it. Running the motor in the forward direction is not possible.

- Note**
- When F02 = 1, the "Run forward" **FWD** and "Run reverse" **REV** terminal commands must be assigned to terminals [FWD] and [REV], respectively.
 - When the FWD or REV is ON, the F02 data cannot be changed.
 - When changing terminal command assignments to terminals [FWD] and [REV] from other configured commands (see E98, E99) to the **FWD** or **REV** with F02 being set to "1," be sure to deactivate the input terminal signals **OFF** beforehand; otherwise, the motor may unintentionally rotate.

■ **3-wire operation with external input signals (digital input terminal commands)**

The default setting of the **FWD** and **REV** are 2-wire. Assigning the terminal command **HLD** self-holds the forward **FWD** or reverse **REV** run command, to enable 3-wire inverter operation. Short-circuiting the **HLD**-assigned terminal and [CM] (i.e., when **HLD** is ON) self-holds the first **FWD** or **REV** at its rising edge. Turning the **HLD** OFF releases the self-holding. When no **HLD** is assigned, 2-wire operation involving only **FWD** and **REV** takes effect.

The HLD input at terminals E01 to E07 is typically a normally closed, momentary stop contact.

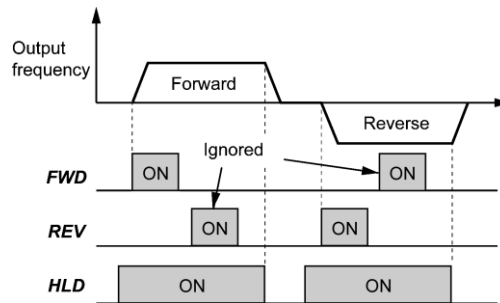

In addition to the run command sources described above, higher priority command sources including remote and local mode (see Section 7.3.6 of the user manual) and communications link are provided. For details, refer to the block diagrams in Chapter 6 in EQ7 User's Manual.

F03 Maximum Frequency 1

F03 specifies the maximum frequency to limit the output frequency. Specifying the maximum frequency exceeding the rating of the equipment driven by the inverter may cause damage or a dangerous situation. Make sure that the maximum frequency setting matches the equipment rating.

- Data setting range: 25.0 to 500.0 (Hz)

- Note**
- For variable torque mode inverters, set the maximum frequency at 120 Hz or below.
 - Under vector control with speed sensor, set the maximum frequency at 200 Hz or below, and under vector control without speed sensor, at 120 Hz or below.
 - If a setting exceeding the maximum setting value (e.g., 500 Hz) is made, the reference speed and analog output (FMA) will be based on the full scale/reference value (10V/500 Hz). However, the frequency is internally limited. Even if 10 V is inputted, the frequency 500 Hz will be internally limited to 200 Hz.

⚠ WARNING

The inverter can easily accept high-speed operation. When changing the speed setting, carefully check the specifications of motors or equipment beforehand.

Otherwise injuries could occur.

- Note** Modifying F03 data to allow a higher reference frequency requires also changing F15 data specifying a frequency limiter (high).

F04 to F05 Base Frequency 1, Rated Voltage at Base Frequency 1
F06 Maximum Output Voltage 1

H50, H51 (Non-linear V/f Pattern 1 (Frequency and Voltage))
H52, H53 (Non-linear V/f Pattern 2 (Frequency and Voltage))
H65, H66 (Non-linear V/f Pattern 3 (Frequency and Voltage))

These function codes specify the base frequency and corresponding voltage at the base frequency essentially required for running the motor properly. If combined with the related function codes H50 through H53, H65 and H66, these function codes may customize the non-linear V/f pattern by specifying increase or decrease in voltage at any point on the V/f pattern.

The following description includes setups required for the non-linear V/f pattern.

At high frequencies, the motor impedance may increase, resulting in an insufficient output voltage and a decrease in output torque. To prevent this problem use F06 (Maximum Output Voltage 1) to increase the voltage. Note, however, that the inverter cannot output voltage exceeding its input power voltage.

V/f point	Function code		Remarks
	Frequency	Voltage	
Maximum frequency	F03	F06	The setting of the maximum output voltage is disabled when the auto torque boost, torque vector control, vector control without speed sensor, or vector control with speed sensor is selected.
Base frequency	F04	F05	
Non-linear V/f pattern 3	H65	H66	Disabled when the auto torque boost, torque vector control, vector control without speed sensor, or vector control with speed sensor is selected.
Non-linear V/f pattern 2	H52	H53	
Non-linear V/f pattern 1	H50	H51	

Examples:

■ **Normal (linear) V/f pattern**

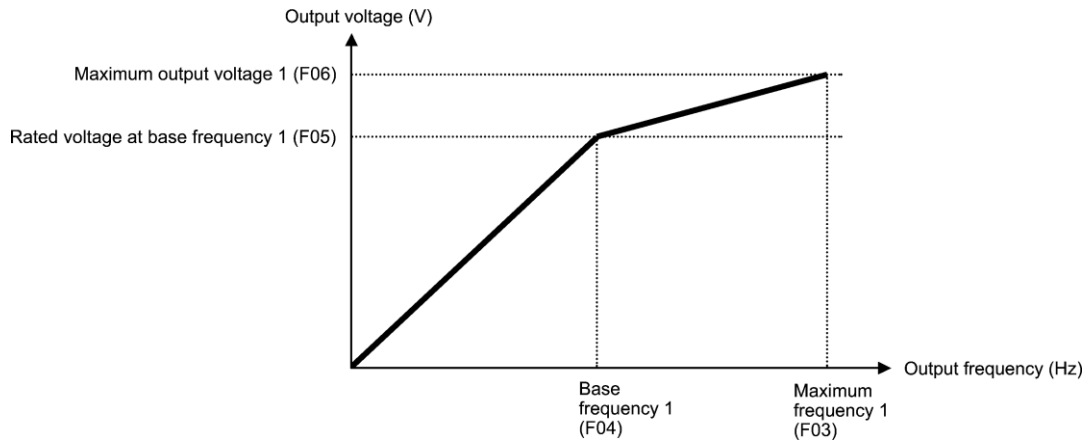

■ **V/f pattern with three non-linear points**

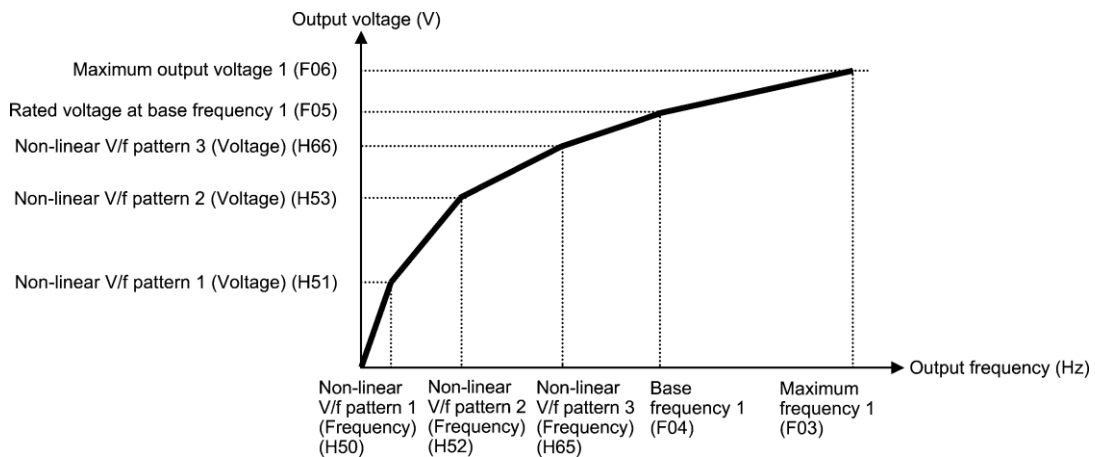

■ **Base Frequency 1 (F04)**

Data setting range: 25.0 to 500.0 (Hz)

Set the rated frequency printed on the nameplate labeled on the motor.

■ **Rated Voltage at Base Frequency 1 (F05)**

Data setting range:

0: Output a voltage in proportion to input voltage (The Automatic Voltage Regulator (AVR) is disabled.)

80 to 240 (V): Output an AVR-controlled voltage for 230 V series

160 to 500 (V): Output an AVR-controlled voltage for 460 V series

Set "0" or the rated voltage printed on the nameplate labeled on the motor.

- If F05 = 0, the rated voltage at base frequency is determined by the AC Line Voltage of the inverter. The output voltage will vary as the input voltage fluctuates.
- If F05 = an arbitrary value other than 0, the inverter automatically keeps the output voltage constant in line with the setting. When any of the auto torque boost, auto energy saving, etc. is enabled, the F05 data should be equal to the rated voltage of the motor.



In vector control, current feedback control is performed. In the current feedback control, the current is controlled with the difference between the motor induced voltage and the inverter output voltage. For a proper control, the inverter output voltage should be sufficiently higher than the motor induced voltage. Generally, the voltage difference is about 20 V for 230 V series, about 40 V for 460 V series.

The maximum voltage the inverter can output cannot exceed the inverter input voltage. Configure these voltages correctly in accordance with the motor specifications.

When enabling the vector control without speed sensor using a general-purpose motor, set the F05 (Rated Voltage at Base Frequency 1) data at the rated voltage of the motor. The voltage difference described above is specified by function code P56 (Induced voltage factor under vector control). Generally, there is no need to modify the initial setting.

■ **Non-linear V/f Patterns 1, 2 and 3 for Frequency (H50, H52 and H65)**



If F05 (Rated Voltage at Base Frequency 1) is set to "0," settings of H50 through H53, H65, H66 and F06 do not take effect. (When the non-linear point is below the base frequency, the linear V/f pattern applies; when it is above, the output voltage is kept constant.)

Data setting range: 0.0 (cancel); 0.1 to 500.0 (Hz)

Set the frequency component at an arbitrary point in the non-linear V/f pattern.



Setting "0.0" to H50, H52 or H65 disables the non-linear V/f pattern operation.

■ **Non-linear V/f Patterns 1, 2 and 3 for Voltage (H51, H53 and H66)**

Data setting range: 0 to 240 (V): Output an AVR-controlled voltage for 230 V series
0 to 500 (V): Output an AVR-controlled voltage for 460 V series

Sets the voltage component at an arbitrary point in the non-linear V/f pattern.

■ **Maximum Output Voltage 1 (F06)**

Data setting range: 80 to 240 (V): Output an AVR-controlled voltage for 230 V series
160 to 500 (V): Output an AVR-controlled voltage for 460 V series

Set the voltage for the maximum frequency 1 (F03).

F07, F08 Acceleration Time 1, Deceleration Time 1

- E10, E12, E14 (Acceleration Time 2, 3 and 4)
- E11, E13, E15 (Deceleration Time 2, 3 and 4)
- H07 (Acceleration/Deceleration Pattern)
- H56 (Deceleration Time for Forced Stop)
- H54, H55 (Acceleration Time/Deceleration Time, Jogging)
- H57 to H60 (1st and 2nd S-curve Acceleration/Deceleration Range)

F07 specifies the acceleration time, the length of time the frequency increases from 0 Hz to the maximum frequency. F08 specifies the deceleration time, the length of time the frequency decreases from the maximum frequency down to 0 Hz.

- Data setting range: 0.00 to 6000 (s)

Under V/f control

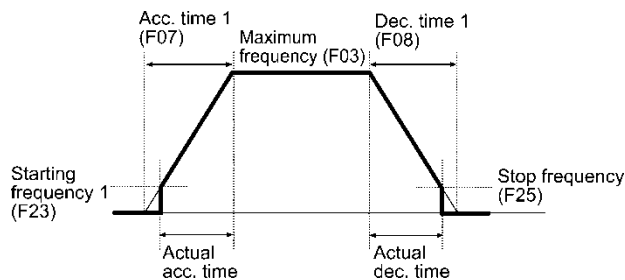

Under vector control without speed sensor

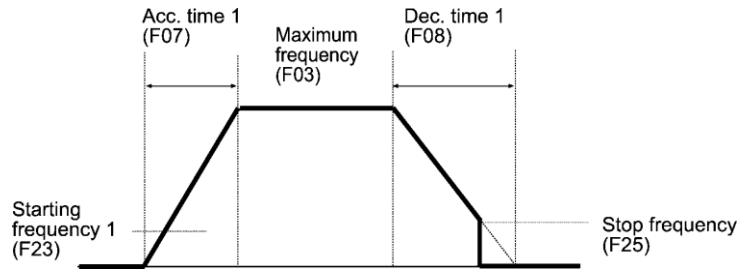

Under vector control with speed sensor

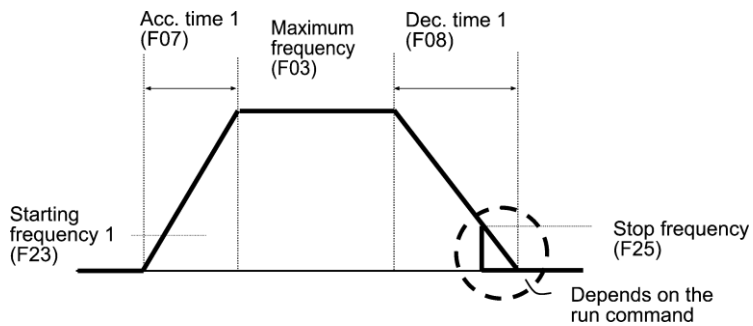

■ Acceleration/deceleration time

Acceleration/ deceleration time	Function code		Switching factor of acceleration/deceleration time (Refer to the descriptions of E01 to E07.)		
	ACC time	DEC time			
Acceleration/ deceleration time 1	F07	F08	<i>RT1</i> OFF	<i>RT2</i> OFF	The combinations of ON/OFF states of the two terminal commands <i>RT2</i> and <i>RT1</i> offer four choices of acceleration/deceleration time 1 to 4. (Data = 4, 5) If no terminal command is assigned, only the acceleration/deceleration time 1 (F07/F08) is effective.
Acceleration/ deceleration time 2	E10	E11	OFF	ON	
Acceleration/ deceleration time 3	E12	E13	ON	OFF	
Acceleration/ deceleration time 4	E14	E15	ON	ON	
At jogging operation	H54	H55	When the terminal command JOG is ON, jogging operation is possible. (Data = 10) (Refer to the description of C20.)		
At forced stop	—	H56	When the terminal command STOP is OFF, the motor decelerates to a stop in accordance with the deceleration time for forced stop (H56). After the motor stops, the inverter enters the alarm state with the alarm <i>er6</i> displayed. (Data = 30)		

■ **Acceleration/Deceleration pattern (H07)**

H07 specifies the acceleration and deceleration patterns (patterns to control output frequency).

Data for H07	Acceleration/ deceleration pattern	Motion		Function code
0	Linear	The inverter runs the motor with the constant acceleration and deceleration.		—
1	S-curve (Fixed)	To reduce an impact that acceleration/deceleration would make on the machine, the inverter gradually accelerates or decelerates the motor in both the starting and ending zones of acceleration or deceleration.	Fixed: The acceleration/deceleration rate to be applied to all of the four inflection zones is fixed at 5% of the maximum frequency.	—
2	S-curve (Adjustable)		Adjustable: The acceleration/deceleration rate can be arbitrarily specified for each of the four inflection zones.	H57 H58 H59 H60
3	Curvilinear	Acceleration/deceleration is linear below the base frequency (constant torque) but it slows down above the base frequency to maintain a certain level of load factor (constant output). This acceleration/deceleration pattern allows the motor to accelerate or decelerate with the maximum performance of the motor.		—

S-curve acceleration/deceleration

To reduce an impact that acceleration/deceleration would make on the machine, the inverter gradually accelerates or decelerates the motor in both the starting and ending zones of acceleration or deceleration. Two types of S-curve acceleration/deceleration rates are available; applying 5% (fixed) of the maximum frequency to all of the four inflection zones, or specifying adjustable rate for each of the four zones with function codes H57 to H60. The reference acceleration/deceleration time determines the duration of acceleration/deceleration in the linear period; hence, the actual acceleration/deceleration time is longer after applying S-curve.

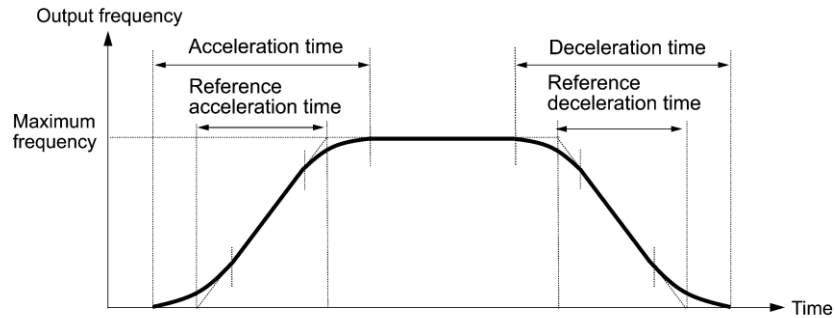

	Acceleration		Deceleration	
	Starting zone	Ending zone	Starting zone	Ending zone
S-curve (Fixed)	5%	5%	5%	5%
S-curve (Adjustable) Setting range: 0 to 100%	H57 Acceleration rate for the 1st S-curve (Leading edge)	H58 Acceleration rate for the 2nd S-curve (Trailing edge)	H59 Deceleration rate for the 1st S-curve (Leading edge)	H60 Deceleration rate for the 2nd S-curve (Trailing edge)

<S-curve acceleration/deceleration (fixed): when the frequency change is 10% or more of the maximum frequency>

$$\text{Acceleration or deceleration time (s)} = (2 \times 5/100 + 90/100 + 2 \times 5/100) \times (\text{reference acceleration or deceleration time}) = 1.1 \times (\text{reference acceleration or deceleration time})$$

<S-curve acceleration/deceleration (adjustable): when the frequency change is 30% or more of the maximum frequency--10% at the leading edge and 20% at the trailing edge>

$$\text{Acceleration or deceleration time (s)} = (2 \times 10/100 + 70/100 + 2 \times 20/100) \times (\text{reference acceleration or deceleration time}) = 1.3 \times (\text{reference acceleration or deceleration time})$$

Curvilinear acceleration/deceleration

Acceleration/deceleration is linear below the base frequency (constant torque) but it slows down above the base frequency to maintain a certain level of load factor (constant output).

This acceleration/deceleration pattern allows the motor to accelerate or decelerate with its maximum performance.

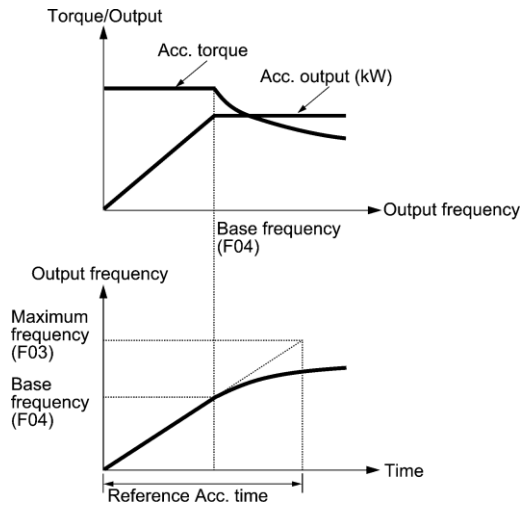

The figures at left show the acceleration characteristics. Similar characteristics apply to the deceleration.



- Choosing S-curve acceleration/deceleration or curvilinear acceleration/deceleration in Acceleration/Deceleration Pattern (H07), extends acceleration/deceleration times are longer than specified times.
- Specifying an improperly short acceleration/deceleration time may activate the current limiter, torque limiter, or anti-regenerative control, resulting in a longer observed acceleration/deceleration time.

F10 to F12 Electronic Thermal Overload Protection for Motor 1
(Select motor characteristics, Overload detection level, and Thermal time constant)

F10 through F12 specify the thermal characteristics of the motor for its electronic thermal overload protection that are used to detect overload conditions of the motor.

Upon detection of overload conditions of the motor, the inverter ceases outputting and issues a motor overload alarm \overline{OL} to protect motor 1.

- Note**
- Thermal characteristics of the motor specified by F10 and F12 are also used for the overload early warning. Even if only using the overload early warning, set these characteristics data to these function codes. (Refer to the description of E34.)
 - For motors with PTC thermistor, connecting the PTC thermistor to the terminal [V2] enables the motor overheat protective function. For details, refer to the description of H26.

■ Select motor characteristics (F10)

F10 selects the cooling mechanism of the motor--shaft-driven or separately powered cooling fan.

Data for F10	Function
1	For a general-purpose motor with shaft-driven cooling fan (The cooling effect will decrease in low frequency operation.)
2	For an inverter-driven motor, non-ventilated motor, or motor with separately powered cooling fan (The cooling effect is constant regardless of the output frequency.)

The figure below shows operating characteristics of the electronic thermal overload protection when F10 = 1. The characteristic factors α_1 through α_3 as well as their corresponding switching frequencies f_2 and f_3 vary with the characteristics of the motor. The tables below list the factors of the motor selected by P99 (Motor 1 Selection).

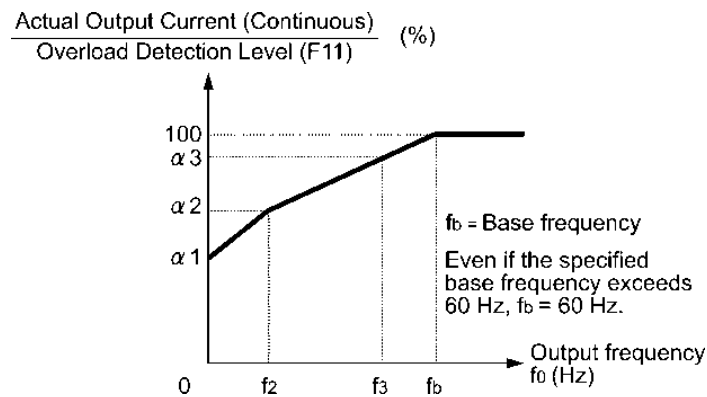

Cooling Characteristics of Motor with Shaft-driven Cooling Fan

Nominal Applied Motor and Characteristic Factors when P99 (Motor 1 selection) = 0 or 4

Nominal applied motor HP	Thermal time constant τ (Factory default)	Reference current for setting the thermal time constant (I_{max})	Output frequency for motor characteristic factor		Characteristic factor (%)		
			f_2	f_3	α_1	α_2	α_3
0.5, 1	5 min	Allowable continuous current $\times 150\%$	5 Hz	7 Hz	75	85	100
2 to 5					85	85	100
7.5 to 15				6 Hz	90	95	100
20				7 Hz	85	85	100
25, 30				5 Hz	92	100	100
40 to 60	10 min		Base frequency $\times 33\%$	Base frequency $\times 83\%$	54	85	95
75 to 125					51	95	95
150 or above					53	85	90

Nominal Applied Motor and Characteristic Factors when P99 (Motor 1 Selection) = 1 or 3

Nominal applied motor HP	Thermal time constant τ (Factory default)	Reference current for setting the thermal time constant (I_{max})	Output frequency for motor characteristic factor		Characteristic factor (%)		
			f_2	f_3	α_1	α_2	α_3
0.25 to 30	5 min	Allowable continuous current $\times 150\%$	Base frequency $\times 33\%$	Base frequency $\times 33\%$	69	90	90
40 to 60	10 min			Base frequency $\times 83\%$	54	85	95
75 to 125					51	95	95
150 or above					53	85	90

If F10 is set to "2," changes of the output frequency do not affect the cooling effect. Therefore, the overload detection level (F11) remains constant.

■ **Overload detection level (F11)**

Data setting range: 1 to 135% of the rated current (allowable continuous drive current) of the inverter

In general, set the F11 data to the allowable continuous current of motor when driven at the base frequency (i.e. 1.0 to 1.1 times of the rated current of the motor.)

To disable the electronic thermal overload protection, set the F11 data to "0.00."

■ **Thermal time constant (F12)** Data setting range: 0.5 to 75.0 (minutes)

F12 specifies the thermal time constant of the motor. If the current of 150% of the overload detection level specified by F11 is attained for the time specified by F12, the electronic thermal overload protection becomes activated to detect the motor overload. The thermal time constant for general-purpose motors is approx. 5 minutes for motors of 30 HP or below and 10 minutes for motors of 40 HP or above by factory default.

(Example) When the F12 data is set at 5 minutes

As shown below, the electronic thermal overload protection is activated to detect an alarm condition (alarm code *DL I*) when the output current of 150% of the overload detection level (specified by F11) is attained for 5 minutes, and 120% for approx. 12.5 minutes.

The actual time required for issuing a motor overload alarm tends to be shorter than the specified value, taking into account the time period from when the output current exceeds the rated current (100%) until it reaches 150% of the overload detection level.

Example of Operating Characteristics

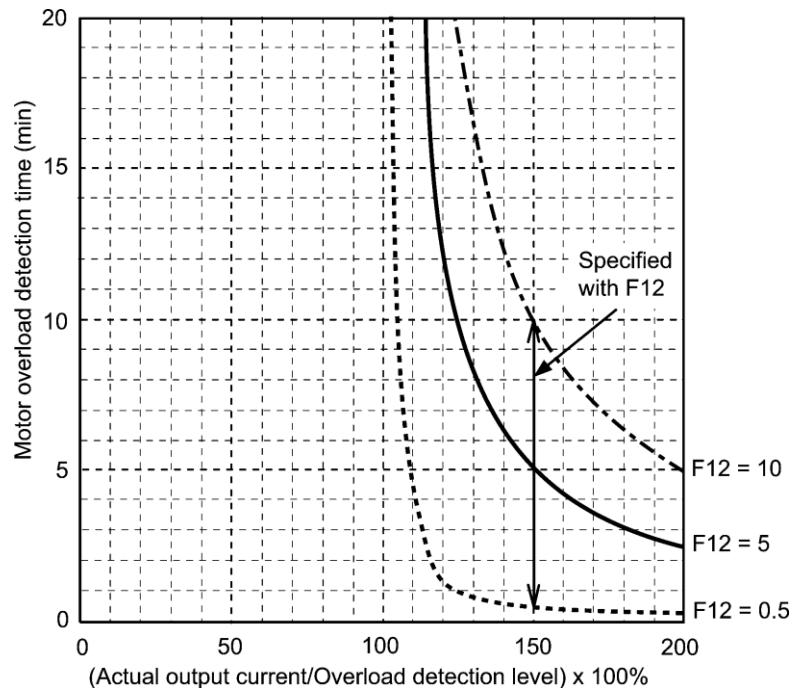

F14

Restart Mode after Momentary Power Failure (Mode selection)

- H13 (Restart Mode after Momentary Power Failure (Restart time))
- H14 (Restart Mode after Momentary Power Failure (Frequency fall rate))
- H15 (Restart Mode after Momentary Power Failure (Continuous running level))
- H16 (Restart Mode after Momentary Power Failure (Allowable momentary power failure time))
- H92 (Continuity of running (P))
- H93 (Continuity of running (I))

F14 specifies the action to be taken by the inverter (trip and restart) in the event of a momentary power failure.

■ **Restart mode after momentary power failure (Mode selection) (F14)**

• **Under V/f control (F42 = 0 or 2)**

Data for F14	Description	
	Auto search disabled	Auto search enabled
0: Trip immediately	As soon as the DC link bus voltage drops below the undervoltage detection level due to a momentary power failure, the inverter issues undervoltage alarm <i>lu</i> and shuts down its output so that the motor enters a coast-to-stop state.	
1: Trip after recovery from power failure	As soon as the DC link bus voltage drops below the undervoltage detection level due to a momentary power failure, the inverter shuts down its output so that the motor enters a coast-to-stop state, but it does not enter the undervoltage state or issue undervoltage alarm <i>lu</i> . The moment the power is restored, an undervoltage alarm <i>lu</i> is issued, while the motor remains in a coast-to-stop state.	
2: Trip after decelerate-to-stop	As soon as the DC link bus voltage drops below the continuous running level due to a momentary power failure, decelerate-to-stop control is invoked. Decelerate-to-stop control regenerates kinetic energy from the load's moment of inertia, slowing down the motor and continuing the deceleration operation. After decelerate-to-stop operation, an undervoltage alarm <i>lu</i> is issued.	
3: Continue to run (for heavy inertia or general loads)	As soon as the DC link bus voltage drops below the continuous running level due to a momentary power failure, continuous running control is invoked. Continuous running control regenerates kinetic energy from the load's moment of inertia, continues running, and waits the recovery of power. When an undervoltage condition is detected due to a lack of energy to be regenerated, the output frequency at that time is saved, the output of the inverter is shut down, and the motor enters a coast-to-stop state.	
	If a run command has been input, restoring power restarts the inverter at the output frequency saved when undervoltage was detected.	If a run command has been input, restoring power performs auto search for idling motor speed and restarts running the motor at the frequency calculated based on the searched speed.
	This setting is ideal for fan applications with a large moment of inertia.	
4: Restart at the frequency at which the power failure occurred (for general loads)	As soon as the DC link bus voltage drops below the undervoltage detection level due to a momentary power failure, the inverter shuts down the output so that the motor enters a coast-to-stop state.	
	If a run command has been input, restoring power restarts the inverter at the output frequency saved when undervoltage was detected.	If a run command has been input, restoring power performs auto search for idling motor speed and restarts running the motor at the frequency calculated based on the searched speed.
	This setting is ideal for applications with a moment of inertia large enough not to slow down the motor quickly, such as fans, even after the motor enters a coast-to-stop state upon occurrence of a momentary power failure.	
5: Restart at the starting frequency	As soon as the DC link bus voltage drops below the undervoltage detection level due to a momentary power failure, the inverter shuts down the output so that the motor enters a coast-to-stop state.	
	If a run command has been input, restoring power restarts the inverter at the starting frequency specified by function code F23.	If a run command has been input, restoring power performs auto search for idling motor speed and restarts running the motor at the frequency calculated based on the searched speed.
	This setting is ideal for heavy load applications such as pumps, having a small moment of inertia, in which the motor speed quickly goes down to zero as soon as it enters a coast-to-stop state upon occurrence of a momentary power failure.	
Auto search is enabled by turning ON the digital terminal command STM ("Enable auto search for idling motor speed at starting") or setting the H09 data to "1" or "2." For details about the digital terminal command STM and auto search, refer to the description of H09 (Starting Mode, Auto search).		

• Under vector control without speed sensor (F42 = 1 or 5)

Data for F14	Description	
	Auto search disabled	Auto search enabled
0: Trip immediately	As soon as the DC link bus voltage drops below the undervoltage detection level due to a momentary power failure, the inverter issues undervoltage alarm <i>lu</i> and shuts down its output so that the motor enters a coast-to-stop state.	
1: Trip after recovery from power failure	As soon as the DC link bus voltage drops below the undervoltage detection level due to a momentary power failure, the inverter shuts down its output so that the motor enters a coast-to-stop state, but it does not enter the undervoltage state or issue undervoltage alarm <i>lu</i> . The moment the power is restored, an undervoltage alarm <i>lu</i> is issued, while the motor remains in a coast-to-stop state.	
2: Trip after decelerate-to-stop	As soon as the DC link bus voltage drops below the continuous running level due to a momentary power failure, decelerate-to-stop control is invoked. Decelerate-to-stop control regenerates kinetic energy from the load's moment of inertia, slowing down the motor and continuing the deceleration operation. After decelerate-to-stop operation, an undervoltage alarm <i>lu</i> is issued.	
3: Continue to run (for heavy inertia or general loads) 4: Restart at the frequency at which the power failure occurred (for general loads)	As soon as the DC link bus voltage drops below the undervoltage detection level due to a momentary power failure, the inverter shuts down the output so that the motor enters a coast-to-stop state. If the F14 data is set to "3," the "Continue to run" function is disabled.	
5: Restart at the starting frequency	If a run command has been input, restoring power restarts the inverter at the output frequency saved when undervoltage was detected.	If a run command has been input, restoring power performs auto search for idling motor speed and restarts running the motor at the frequency calculated based on the searched speed.
	If a run command has been input, restoring power restarts the inverter at the starting frequency specified by function code F23.	If a run command has been input, restoring power performs auto search for idling motor speed and restarts running the motor at the frequency calculated based on the searched speed.
	This setting is ideal for heavy load applications such as pumps, having a small moment of inertia, in which the motor speed quickly goes down to zero as soon as it enters a coast-to-stop state upon occurrence of a momentary power failure.	
Auto search is enabled by turning ON the digital terminal command STM ("Enable auto search for idling motor speed at starting") or setting the d67 data to "1" or "2." For details about the digital terminal command STM and auto search, refer to the description of d67 (Starting Mode, Auto search).		

• Under vector control with speed sensor (F42 = 6)

Data for F14	Description
0: Trip immediately	As soon as the DC link bus voltage drops below the undervoltage detection level due to a momentary power failure, the inverter issues undervoltage alarm <i>lu</i> and shuts down its output so that the motor enters a coast-to-stop state.
1: Trip after recovery from power failure	As soon as the DC link bus voltage drops below the undervoltage detection level due to a momentary power failure, the inverter shuts down its output so that the motor enters a coast-to-stop state, but it does not enter the undervoltage state or issue undervoltage alarm <i>lu</i> . The moment the power is restored, an undervoltage alarm <i>lu</i> is issued, while the motor remains in a coast-to-stop state.
2: Trip after decelerate-to-stop	As soon as the DC link bus voltage drops below the continuous running level due to a momentary power failure, decelerate-to-stop control is invoked. Decelerate-to-stop control regenerates kinetic energy from the load's moment of inertia, slowing down the motor and continuing the deceleration operation. After decelerate-to-stop operation, an undervoltage alarm <i>lu</i> is issued.
3: Continue to run (for heavy inertia or general loads) 4: Restart at the frequency at which the power failure occurred (for general loads) 5: Restart at the starting frequency	As soon as the DC link bus voltage drops below the undervoltage detection level due to a momentary power failure, the inverter shuts down the output so that the motor enters a coast-to-stop state. If the F14 data is set to "3," the "Continue to run" function is disabled. If a run command has been input, restoring power restarts the inverter at the motor speed detected by the speed sensor.

⚠ WARNING

If you enable the "Restart mode after momentary power failure" (Function code F14 = 3, 4, or 5), the inverter automatically restarts the motor running when the power is recovered. Design the machinery or equipment so that personnel safety is ensured after restarting.

Otherwise an accident could occur.

■ Restart mode after momentary power failure (Basic operation with auto search disabled)

The inverter recognizes a momentary power failure upon detecting the condition that DC link bus voltage goes below the undervoltage detection level, while the inverter is running. If the load of the motor is light and the duration of the momentary power failure is extremely short, the voltage drop may not be great enough for a momentary power failure to be recognized, and the motor may continue to run uninterrupted.

Upon recognizing a momentary power failure, the inverter enters the restart mode (after a recovery from momentary power failure) and prepares for restart. When power is restored, the inverter goes through an initial charging stage and enters the ready-to-run state. When a momentary power failure occurs, the power supply voltage for external circuits such as relay sequence circuits may also drop so as to disable the run command. If this occurs, the inverter waits 2 seconds for a run command input after the inverter enters a ready-to-run state. When received; the inverter begins the restart processing in accordance with the F14 data (Mode selection). If no run command has been received within 2-seconds, the inverter cancels the restart mode (after a recovery from momentary power failure) and needs to be started again at starting frequency. Therefore, ensure that a run command is entered within 2 seconds after a recovery of power, or install a mechanical latch relay.

When starting and stopping via the keypad (F02=0), the above operation will also apply regardless of the whether FWD, REV, or F02 = 2 or 3 sets rotational direction.

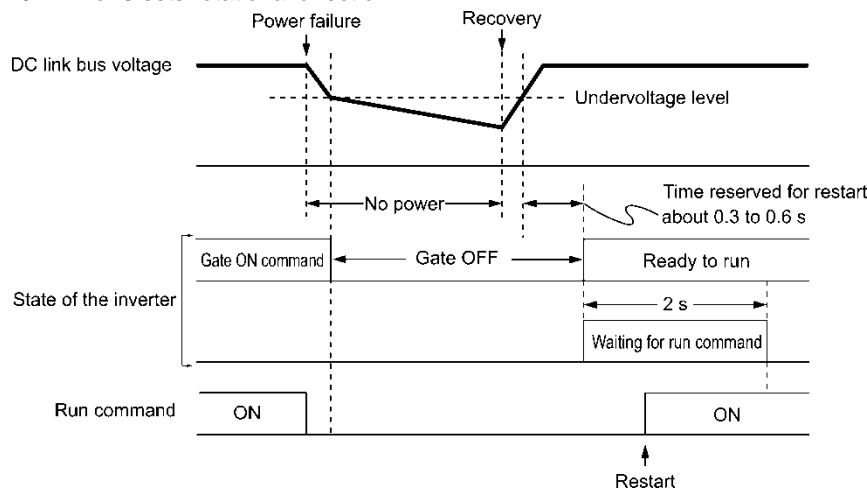

- Note**
- When the power is restored, the inverter will wait up to 2 seconds for a run command. However, the setting of H16 (allowable momentary power failure supply) overrides the 2 second limit if set below 2 seconds.
 - If the "Coast to a stop" terminal command **BX** is entered during the power failure, the inverter exits the restart mode and enters the normal running mode. If a run command is entered with power applied, the inverter will start from the normal starting frequency.
 - The inverter recognizes a momentary power failure by detecting an undervoltage condition whereby the voltage of the DC link bus goes below the lower limit. In a configuration where a magnetic contactor is installed on the output side of the inverter, the inverter may fail to recognize a momentary power failure because it also may shut down the operating power of the magnetic contactor, causing the contactor circuit to open. If this occurs, the inverter is cut off from the motor and load, and the voltage drop in the DC link bus is not great enough to be recognized as a power failure. In such an event, restart after a recovery from momentary power failure does not work properly as designed. To remedy this, connect the interlock command **IL** line to the auxiliary contact of the magnetic contactor, so that a momentary power failure can sure be detected. For details, refer to the descriptions of E01 through E07.

Function code E01 to E07, data = 22

IL	Description
OFF	No momentary power failure has occurred.
ON	A momentary power failure has occurred. (Restart after a momentary power failure enabled)

During a momentary power failure, the motor slows down. After power is restored, the inverter restarts at the frequency just prior to power failure. Then, the current limiting function works and the output frequency of the inverter automatically decreases. When the output frequency matches the motor speed, the motor accelerates up to the output frequency. See the figure below. (In this case, the instantaneous overcurrent limiting must be enabled (H12 = 1)).

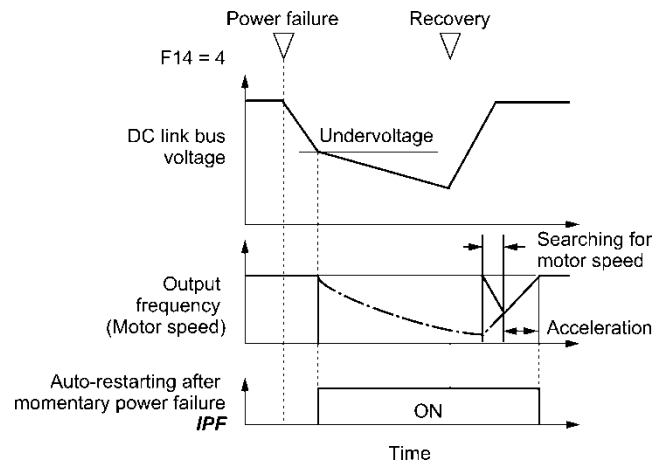

• **Auto-restarting after momentary power failure *IPF***

This output signal is ON during the period after the occurrence of momentary power failure until the completion of restart (the output has reached the reference frequency). Beware that when the *IPF* is ON, the motor slows down. (For details about *IPF*, refer to E20 through E24 and E27 (data = 6).)

■ **Restart mode after momentary power failure (Basic operation with auto search enabled)**

Auto search for idling motor speed fails if it is done while the motor retains residual voltage. It is therefore necessary to leave sufficient time for the motor (auto search delay time) to discharge the residual voltage. The delay time is specified by H46 (Starting Mode (Auto search delay time 2)).

The inverter will not start unless the time specified by H46 has elapsed, even if the starting conditions are satisfied. (For details, refer to H09 and d67.)

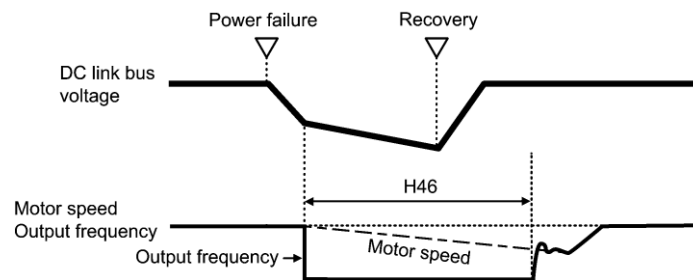

- Note
- To use auto search for idling motor speed, it is necessary to have tuned the inverter.
 - When the estimated speed exceeds the maximum frequency or the upper limit frequency, the inverter disables auto search and starts running the motor at that frequency.
 - During auto search, if an overcurrent or overvoltage trip occurs, the inverter restarts the suspended auto search.
 - Perform auto search at 60 Hz or below.
 - Note that auto search may not fully provide the performance depending on load conditions, motor parameters, wiring length, and other external factors.
 - Do not execute motor tuning with output filter unless the filter is a reactor type only. A tuning error may result otherwise.

■ **Restart mode after momentary power failure (Allowable momentary power failure time) (H16)**

H16 specifies the maximum allowable duration (0.0 to 30.0 seconds) from an occurrence of a momentary power failure (undervoltage) until the inverter is to be restarted. Specify the coast-to-stop time which the machine system and facility can tolerate.

If the power is restored within the specified duration, the inverter restarts in the restart mode specified by F14. If not, the inverter recognizes that the power has been shut down and the inverter does not apply the restart mode.

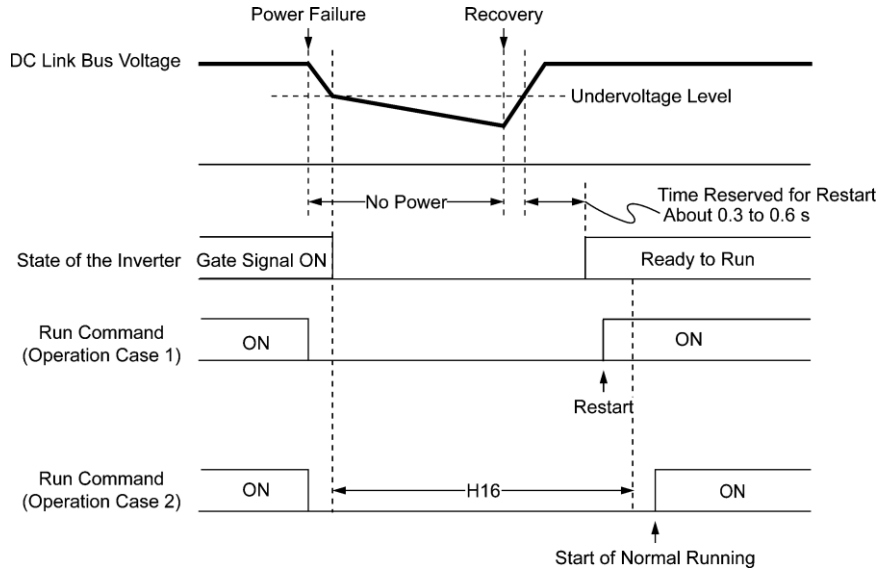

If H16 (Allowable momentary power failure time) is set to "999," restart will take place until the DC link bus voltage drops down to the minimum allowable voltage for restart after a momentary power failure (50 V for 230 V series and 100 V for 460 V series). If the DC link bus voltage drops below the allowable voltage, the inverter recognizes that the power has been shut down and does not restart.

Power supply voltage	Allowable voltage for restart after momentary power failure
230 V series	50 V
460 V series	100 V

Note The time required from when the DC link bus voltage drops from the threshold of undervoltage until it reaches the allowable voltage for restart after a momentary power failure greatly varies depending on the inverter capacity, the presence of options, and other factors.

■ **Restart mode after momentary power failure (Restart time) (H13)**

H13 specifies the time period from momentary power failure occurrence until the inverter reacts for restarting process.

If the inverter starts the motor while motor's residual voltage is still in a high level, a large inrush current may flow or an overvoltage alarm may occur due to an occurrence of temporary regeneration. For safety, therefore, it is advisable to set H13 to a certain level so that the restart will take place only after the residual voltage has dropped to a low level. Note that even when power is restored, restart will not take place until the restart time (H13) has elapsed.

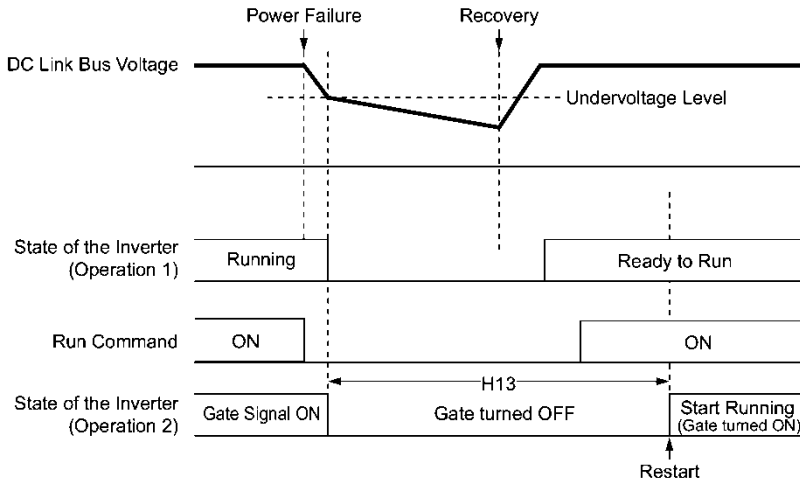

Factory default: By factory default, H13 is set to a matched value for the standard motor (see Table A in Section 5.1 "Function Code Tables"). Basically, it is not necessary to change H13 data. However, if the long restart time causes deteriorated performance or causes any other problem, reduce the setting to about a half of the default value, ensuring that no alarm occurs.

Note Function code H13 (Restart mode after momentary power failure -- Restart time) also applies to the switching operation between line and inverter (refer to the descriptions of E01 through E07).

■ **Restart mode after momentary power failure (Frequency fall rate) (H14)**

During restart after a momentary power failure, if the inverter output frequency and the idling motor speed cannot be harmonized with each other, an overcurrent persists, activating the overcurrent limiter. If it happens, the inverter automatically reduces the output frequency to match the idling motor speed according to the reduction rate (Frequency fall rate: Hz/s) specified by H14.

Data for H14	Inverter's action for the output frequency fall
0.00	Follow the deceleration time specified
0.01 to 100.00 (Hz/s)	Follow data specified by H14
999	Follow the setting of the PI controller in the current limiter. (The PI constant is prefixed inside the inverter.)

Note If the frequency drop rate is too high, regeneration may take place at the moment the motor rotation matches the inverter output frequency, causing an overvoltage trip. On the contrary, if the frequency fall rate is too low, the time required for the output frequency to match the motor speed (duration of current limiting action) may be excessive, triggering the inverter overload prevention control.

■ **Restart after momentary power failure (Continuous running level) (H15)
Continuity of running (P and I) (H92, H93)**

• **Trip after decelerate-to-stop**

If a momentary power failure occurs when F14 is set to "2" (Trip after decelerate-to-stop), the inverter enters the control sequence of the decelerate-to-stop when the DC link bus voltage drops below the continuous running level specified by H15.

Under the decelerate-to-stop control, the inverter decelerates its output frequency keeping the DC link bus voltage constant using the PI processor. (P (proportional) and I (integral) components of the PI processor are specified by H92 and H93, respectively.)

For normal inverter operation, it is not necessary to modify H15, H92 or H93.

• **Continue to run**

If a momentary power failure occurs when F14 is set to "3" (Continue to run), the inverter enters the control sequence of the continuous running when the DC link bus voltage drops below the continuous running level specified by H15.

Under the continuous running control, the inverter continues to run keeping the DC link bus voltage constant using the PI processor. (P (proportional) and I (integral) components of the PI processor are specified by H92 and H93, respectively.) For normal inverter operation, it is not necessary to modify H15, H92 or H93.

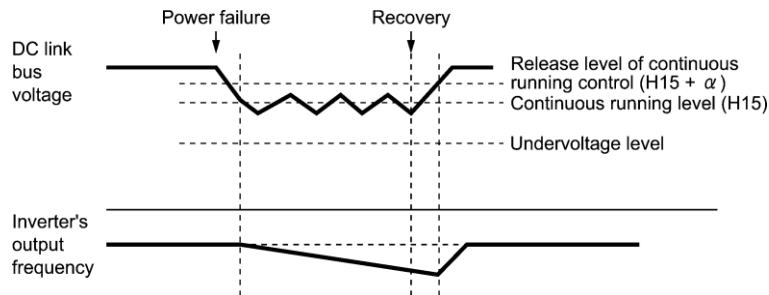

Power supply voltage	α	
	40 HP or below	50 HP or above
230 V series	5 V	10 V
460 V series	10 V	20 V

Note Even if selecting "Trip after decelerate-to-stop" or "Continue to run," the inverter may not be able to do so when the load's inertia is small or the load is heavy, due to undervoltage caused by a control delay. In such a case, when "Trip after decelerate-to-stop" is selected, the inverter allows the motor to coast to a stop; when "Continue to run" is selected, the inverter saves the output frequency being applied when the undervoltage alarm occurred and restarts at the saved frequency after a recovery from the momentary power failure.

When the input power voltage for the inverter is high, setting the continuous running level high makes the control more stable even if the load's inertia is relatively small. Raising the continuous running level too high, however, might cause the continuous running control activated even during normal operation.

When the input power voltage for the inverter is extremely low, continuous running control might be activated even during normal operation, at the beginning of acceleration or at an abrupt change in load. To avoid this, lower the continuous running level. However, possible undervoltage results from voltage drop due to a control delay if set too low.

Changing the continuous running level, make sure that the continuous running control will be performed properly, by considering the fluctuations of the load and the input voltage.

F15, F16 Frequency Limiter (High), Frequency Limiter (Low)

H63 Low Limiter (Mode selection)

■ **Frequency Limiter (High and Low) (F15, F16)** Data setting range: 0.0 to 500.0 (Hz)

F15 and F16 specify the upper and lower limits of the output frequency or reference frequency, respectively. The frequency to which the limit is applied differs depending on the control system, as seen in the table.

Frequency Limiter		Frequency to which the limit is applied	
		V/f control	Vector control without/with speed sensor
Frequency Limiter (High)	F15	Output frequency	Reference speed (reference frequency)
Frequency Limiter (Low)	F16	Reference frequency	Reference speed (reference frequency)

Note When the limit is applied to the reference frequency or reference speed, delayed responses of control may cause an overshoot or undershoot, and the frequency may temporarily go beyond the limit level.

■ **Low Limiter (Mode selection) (H63)**

H63 specifies the operation to be carried out when the reference frequency drops below the low level specified by F16, as follows:

Data for H63	Operation
0	The output frequency will be held at the low level specified by F16.
1	The inverter decelerates to stop the motor.

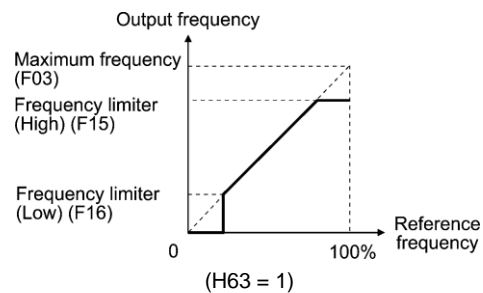
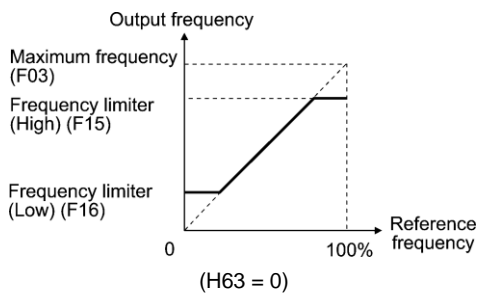

- Note**
- When changing the frequency limiter (High) (F15) in order to raise the reference frequency, be sure to change the maximum frequency (F03) accordingly.
 - Maintain the following relationship among the data for frequency control:
 $F15 > F16$, $F15 > F23$, and $F15 > F25$
 $F03 > F16$
 where, F23 and F25 specify the starting and stop frequencies, respectively.
 If any erroneous data for these function codes is entered, the inverter may not run the motor at the desired speed, nor start it normally.

F20 to F22 DC Braking 1 (Braking starting frequency, Braking level, and Braking time)
H95 DC Braking (Braking response mode)

F20 through F22 specify the DC braking that prevents motor 1 from running by inertia during decelerate-to-stop operation.

If the motor decelerates-to-stop by turning OFF the run command or by decreasing the reference frequency below the stop frequency, the inverter activates the DC braking by injecting current at the braking level (F21) during the braking time (F22) when the output frequency is at or below the DC braking starting frequency (F20).

Setting the braking time to "0.0" (F22 = 0) disables the DC braking.

■ **Braking starting frequency (F20)** Data setting range: 0.0 to 60.0 (Hz)

F20 specifies the frequency at which the DC braking starts its operation during motor decelerate-to-stop state.

■ **Braking level (F21)** Data setting range: 0 to 80 (%) Variable/Constant torque inverters
 0 to 100 (%) CT-Vector-mode inverters

F21 specifies the output current level to be applied when the DC braking is activated. The function code data should be set, assuming the rated output current of the inverter as 100%, in increments of 1%.

Note The inverter rated output current differs between the variable torque and constant torque modes.
 0% to 100% for inverters of 7.5 HP or below.

■ **Braking time (F22)** Data setting range: 0.01 to 30.00 (s), 0.00 (Disable)

F22 specifies the braking period that activates DC braking.

■ **Braking response mode (H95)**

H95 specifies the DC braking response mode. When vector control without/with speed sensor is selected, the response is constant.

Data for H95	Characteristics	Note
0	Slow response. Slows the rising edge of the current, thereby preventing reverse rotation at the start of DC braking.	Insufficient braking torque may result at the start of DC braking.
1	Quick response. Quickens the rising edge of the current, thereby accelerating the build-up of the braking torque.	Reverse rotation may result depending on the moment of inertia of the mechanical load and the coupling mechanism.

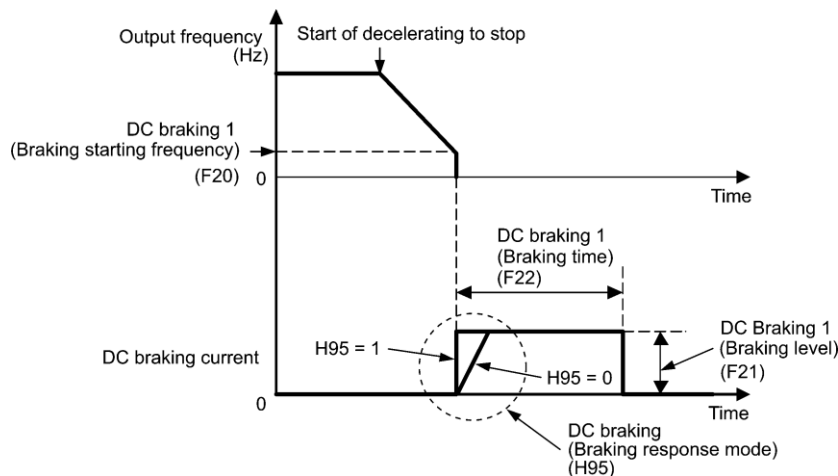



It is also possible to use an external digital input signal as an "Enable DC braking" terminal command **DCBRK**. As long as the **DCBRK** command is ON, the inverter performs DC braking, regardless of the braking time specified by F22.
(📖 Refer to E01 through E07, data =13.)

Turning the **DCBRK** command ON even when the inverter is in a stopped state activates the DC braking. This feature allows the motor to be excited before starting, resulting in smoother acceleration (quicker build-up of acceleration torque) (under V/f control).

When vector control without/with speed sensor is selected, use the pre-exciting feature for establishing the magnetic flux. (📖 For details, refer to H84.)

In general, DC braking is used to prevent the motor rotation by inertia during the stopping process. Under vector control with speed sensor, however, zero speed control will be more effective for applications where load is applied to the motor even in a stopped state.

If the zero speed control continues for a long time, the motor may slightly rotate due to a control error. To eliminate any rotation, use the servo-lock function. (📖 For details, refer to J97.)



In general, specify data of function code F20 at a value close to the rated slip frequency of motor. If setting is at an extremely high value, control may become unstable and an overvoltage alarm may result in some cases.

⚠ WARNING

Even if the motor is stopped by DC braking, voltage is output to inverter output terminals U, V, and W.
An electric shock may occur.

⚠ CAUTION

The DC brake function of the inverter does not provide any holding mechanism.
Injuries could occur.

F23 to F25 Starting Frequency 1, Starting Frequency 1 (Holding time), Stop Frequency

F38 (Stop Frequency (Detection mode))	F39 (Stop Frequency (Holding time))
H92 (Continuity of Running (P))	H93 (Continuity of Running (I))
d24 (Zero Speed Control)	

Under V/f control

At the startup of an inverter, the initial output frequency is equal to the starting frequency. The inverter shuts off its output when the output frequency reaches the stop frequency.

Set the starting frequency to a level at which the motor can generate enough torque for startup. Generally, set the motor's rated slip frequency as the starting frequency.

Specifying the holding time for the starting frequency compensates for the delay time for the establishment of a magnetic flux in the motor; specifying that for the stop frequency stabilizes the motor speed at the stop of the inverter.

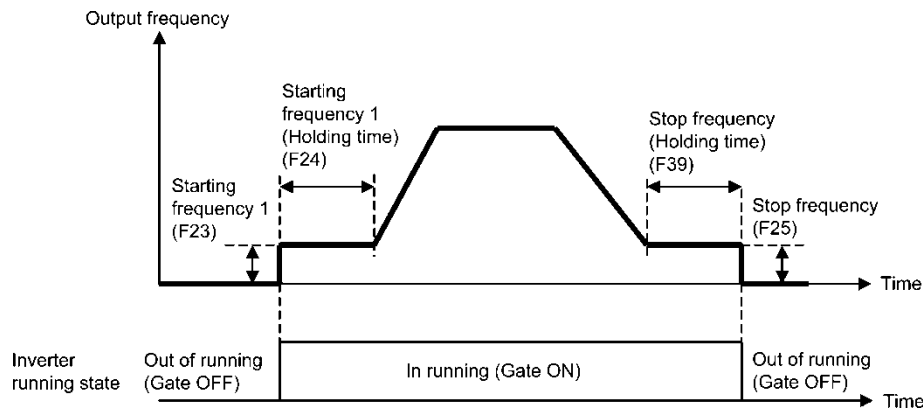

■ Starting frequency 1 (F23)

Data setting range: 0.0 to 60.0 (Hz)

F23 specifies the starting frequency at the startup of an inverter. Under V/f control, even if the starting frequency is set at 0.0 Hz, the inverter starts at 0.1 Hz.

■ **Starting frequency 1 (Holding time) (F24)** Data setting range: 0.00 to 10.00 (s)

F24 specifies the holding time for the starting frequency 1.

■ **Stop frequency (F25)** Data setting range: 0.0 to 60.0 (Hz)

F25 specifies the stop frequency at the stop of the inverter. Under V/f control, even if the stop frequency is set at 0.0 Hz, the inverter stops at 0.1 Hz.

■ **Stop frequency (Holding time) (F39)** Data setting range: 0.00 to 10.00 (s)

F39 specifies the holding time for the stop frequency.

Note If the starting frequency is lower than the stop frequency, the inverter will not output any power as long as the reference frequency does not exceed the stop frequency.

Under vector control with/without speed sensor (F42 = 5, 6)

At the startup, the inverter first starts at the "0" speed and accelerates to the starting frequency according to the specified acceleration time. After holding the starting frequency for the specified period, the inverter again accelerates to the reference speed according to the specified acceleration time.

The inverter stops its output when the reference speed or detected one (specified by F38) reaches the stop frequency specified by F25.

Specifying the holding time for the starting frequency compensates for the delay time for the establishment of a magnetic flux in the motor; specifying that for the stop frequency stabilizes the motor speed at the stop of the inverter.

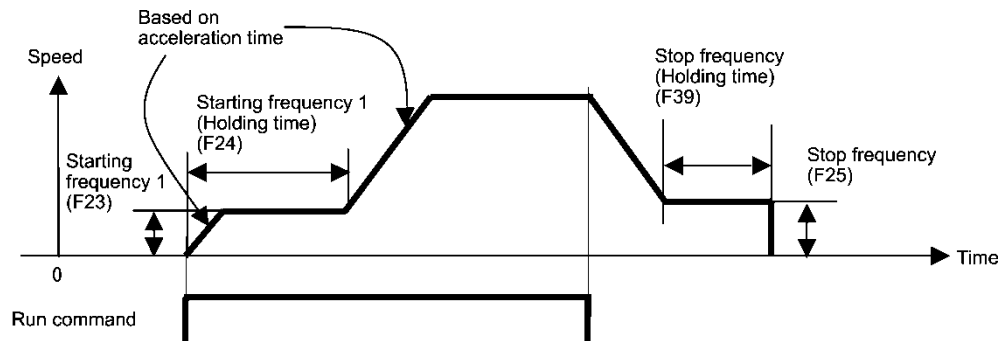

■ **Starting Frequency 1 (F23)** Data setting range: 0.0 to 60.0 (Hz)

F23 specifies the starting frequency at the startup of an inverter.

■ **Starting Frequency 1 (Holding time) (F24)** Data setting range: 0.00 to 10.00 (s)

F24 specifies the holding time for the starting frequency 1.

■ **Stop Frequency (F25)** Data setting range: 0.0 to 60.0 (Hz)

F25 specifies the stop frequency at the stop of the inverter.

■ **Stop Frequency (Holding time) (F39)** Data setting range: 0.00 to 10.00 (s)

F39 specifies the holding time for the stop frequency.

■ **Zero Speed Control (d24)**

To enable zero speed control under vector control with speed sensor, it is necessary to set the speed command (frequency command) at below the starting and stop frequencies. If the starting and stop frequencies are 0.0 Hz, however, the zero speed control is enabled only when the speed command is 0.00 Hz. d24 specifies the operation for the zero speed control at the startup of the inverter.

Data for d24	Zero speed control	Descriptions
0	Not allowed at startup	Even setting the speed command at below the starting and stop frequencies and turning a run command ON does not enable the zero speed control. To enable the zero speed control, set the speed command at above the starting frequency and then start up the inverter again.
1	Allowed at startup	Setting the speed command at below the starting and stop frequencies and turning a run command ON enables the zero speed control.

The table below shows the conditions for zero speed control to be enabled or disabled.

	Speed command	Run command	Data for d24	Operation
At startup	Below the starting and stop frequencies	OFF	—	Stop (Gate OFF)
		ON	0	Stop (Gate OFF)
			1	Zero speed control
At stop	Below the stop frequency	ON	—	Zero speed control
		OFF	—	Stop (Gate OFF)

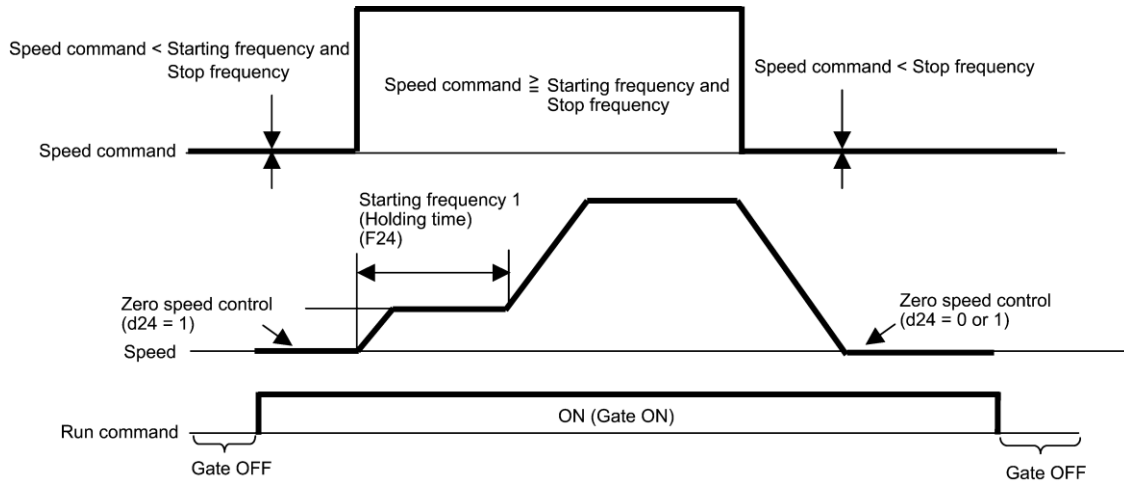

■ **Stop Frequency (Detection mode) (F38) (Under vector control with speed sensor)**

F38 specifies whether to use the detected or reference speed as criterion to shut down the inverter output. Usually the inverter uses the detected speed. However, if the inverter undergoes a load exceeding its capability, e.g., an external excessive load, the motor cannot stop so that the detected speed may not reach the stop frequency level. When such a situation arises, select an appropriate speed that can reach the stop frequency level even if the detected speed does not, in order to stop the inverter without fail for general fail-safe operation.

- Data setting range: 0 (Detected speed)
- 1 (Reference speed)

■ Motor Sound (Carrier frequency) (F26)

F26 controls the carrier frequency so as to reduce an audible noise generated by the motor or electromagnetic noise from the inverter itself, and to decrease a leakage current from the main output (secondary) wirings.

Item	Characteristics	Remarks
Carrier frequency	0.75 to 16 kHz	0.5 to 30 HP (VT mode) 0.5 to 75 HP (CT, CT-V mode)
	0.75 to 10 kHz	40 to 100 HP (VT mode) 125 to 800 HP (CT-V mode)
	0.75 to 6 kHz	125 to 900 HP (VT mode) 800 and 900 HP (CT-V mode)
	0.75 to 4 kHz	1000 HP (VT mode)
	0.75 to 2 kHz	150 to 700HP (CT Mode)
Motor sound noise emission	High ↔ Low	
Motor temperature (due to harmonics components)	High ↔ Low	
Ripples in output current waveform	Large ↔ Small	
Leakage current	Low ↔ High	
Electromagnetic noise emission	Low ↔ High	
Inverter loss	Low ↔ High	

VT = Variable Torque, CT = Constant Torque, CT-V = Constant Torque Vector

Note Specifying a too low carrier frequency will cause the output current waveform to have a large amount of ripples. As a result, the motor loss increases, causing the motor temperature to rise. Furthermore, the large amount of ripples tends to cause a current limiting alarm. When the carrier frequency is set to 1 kHz or below, therefore, reduce the load so that the inverter output current comes to be 80% or less of the rated current.

When a high carrier frequency is specified, the temperature of the inverter may rise due to a surrounding temperature rise or an increase of the load. If it happens, the inverter automatically decreases the carrier frequency to prevent the inverter overload alarm *Olu*. With consideration for motor noise, the automatic reduction of carrier frequency can be disabled. Refer to the description of H98.

It is recommended to set the carrier frequency at 5 kHz or above under vector control without/with speed sensor. DO NOT set it at 1 kHz or below.

■ Motor Sound (Tone) (F27)

F27 changes the motor running sound tone (only for motors under V/f control). This setting is effective when the carrier frequency specified by function code F26 is 7 kHz or lower. Changing the tone level may reduce the high and harsh running noise from the motor.

Note If the tone level is set too high, the output current may become unstable, or mechanical vibration and noise may increase.

Also, this function code may not be very effective for certain types of motor.

Data for F27	Function
0	Disable (Tone level 0)
1	Enable (Tone level 1)
2	Enable (Tone level 2)
3	Enable (Tone level 3)

F29 to F31 Analog Output [FM1] and [FM2] (Mode selection, Voltage adjustment, Function)
F32, F34,
F35

These function codes allow terminals [FM1] and [FM2] to output monitored data such as the output frequency and the output current in an analog DC voltage or current. The magnitude of analog voltage or current is adjustable.

■ **Mode selection (F29 and F32)**

F29 and F32 specify the type of signal to terminals [FM1] and [FM2], respectively. Set the slide switches on the control printed circuit board properly (control PCB). Refer to Chapter 2 "Mounting and Wiring of the Inverter."

Output form	Terminal [FM1]		Terminal [FM2]	
	F29	Position of slide switch SW4 on the control PCB	F32	Position of slide switch SW6 on the control PCB
Voltage (0 to +10 VDC)	0	VO1	0	VO2
Current (4 to +20 mA DC)	1	IO1	1	IO2
Current (0 to +20 mA DC)	2	IO1	2	IO2

Note The output current is not isolated from analog input, and does not have an isolated power supply. Therefore, if an electrical potential relationship between the inverter and peripheral equipment has been established, e.g., by connecting an analog, cascade connection of a current output device is not available.

Keep the connection wire length as short as possible.

■ **Voltage adjustment (F30 and F34)**

F30 adjusts the output voltage within the range of 0 to 300%.

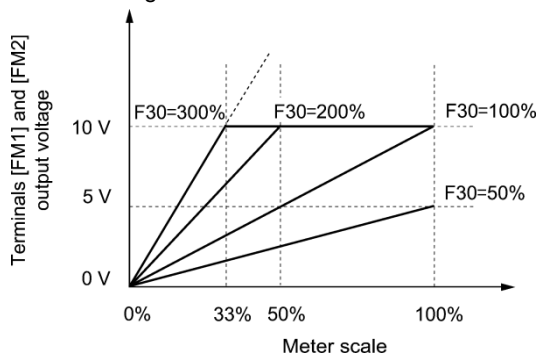

■ **Function (F31 and F35)**

F31 and F35 specify what is output to analog output terminals [FM1] and [FM2], respectively.

Data for F31/F35	[FM1]/[FM2] output	Function (Monitor the following)	Meter scale (Full scale at 100%)
0	Output frequency 1 (before slip compensation)	Output frequency of the inverter (Equivalent to the motor synchronous speed)	Maximum frequency (F03)
1	Output frequency 2 (after slip compensation)	Output frequency of the inverter	Maximum frequency (F03)
2	Output current	Output current (RMS) of the inverter	Twice the inverter rated current
3	Output voltage	Output voltage (RMS) of the inverter	250 V for 230 V series, 500 V for 460 V series
4	Output torque	Motor shaft torque	Twice the rated motor torque
5	Load factor	Load factor (Equivalent to the indication of the load meter)	Twice the rated motor load
6	Input power	Input power of the inverter	Twice the rated output of the inverter
7	PID feedback amount (PV)	Feedback amount under PID control	100% of the feedback amount

Data for F31/F35	[FM1]/[FM2] output	Function (Monitor the following)	Meter scale (Full scale at 100%)
8	PG feedback value (speed)	Speed detected through the PG interface, or estimated speed under vector control without speed sensor	Maximum speed as 100%
9	DC link bus voltage	DC link bus voltage of the inverter	500 V for 230 V series, 1000 V for 460 V series
10	Universal AO	Command via communications link (Refer to the RS-485 Communication User's Manual.)	20000 as 100%
13	Motor output	Motor output (kW)	Twice the rated motor output
14	Calibration (+)	Full scale output of the meter calibration	This always outputs the full-scale (100%).
15	PID command (SV)	Command value under PID control	100% of the feedback amount
16	PID output (MV)	Output level of the PID controller under PID control (Frequency command)	Maximum frequency (F03)
17	Positional deviation in synchronous running	Deviation in angle	0% to 50% to 100%, representing -180° to 0° to +180° of the deviation

Note If F31/F35 = 16 (PID output), J01 = 3 (Dancer control), and J62 = 2 or 3 (Ratio compensation enabled), the PID output is equivalent to the ratio against the primary reference frequency and may vary within $\pm 300\%$ of the frequency. The monitor displays the PID output in a converted absolute value. To indicate the value up to the full-scale of 300%, set F30/F34 data to "33" (%).

F37 Load Selection/ Auto Torque Boost/ Auto Energy Saving Operation 1

F09 (Torque Boost 1)

H67 (Auto Energy Saving Operation (Mode selection))

F37 specifies V/f pattern, torque boost type, and auto energy saving operation in accordance with the characteristics of the load.

Specify the torque boost level with F09 in order to assure sufficient starting torque.

Data for F37	V/f pattern	Torque boost	Auto energy saving	Applicable load
0	Variable torque V/f pattern	Torque boost specified by F09	Disable	Variable torque load (General-purpose fans and pumps)
1	Linear V/f pattern	Auto torque boost		Constant torque load
2				Constant torque load (To be selected if a motor may be over-excited at no load.)
3	Variable torque V/f pattern	Torque boost specified by F09	Enable	Variable torque load (General-purpose fans and pumps)
4	Linear V/f pattern	Auto torque boost		Constant torque load
5				Constant torque load (To be selected if a motor may be over-excited at no load.)

Note If a required "load torque + acceleration torque" is more than 50% of the constant torque, it is recommended to select the linear V/f pattern (factory default).

Tip Under the vector control with speed sensor, F37 is used to specify whether the auto energy saving operation is enabled or disabled. (V/f pattern and torque boost are disabled.)

Data for F37	Operation
0 to 2	Auto energy saving operation OFF
3 to 5	Auto energy saving operation ON

Under the vector control without speed sensor, both F37 and F09 are disabled. The auto energy saving operation is also disabled.

■ **V/f characteristics**

The EQ7 series of inverters offers a variety of V/f patterns and torque boosts, which include V/f patterns suitable for variable torque load such as general fans and pumps and for constant torque load (including special pumps requiring high starting torque). Two types of torque boosts are available: manual and automatic.

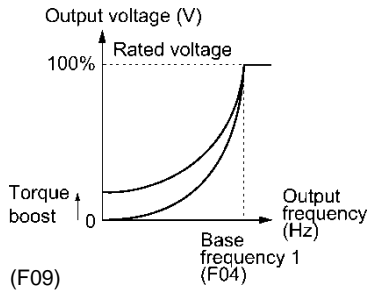

Variable torque V/f pattern (F37 = 0)

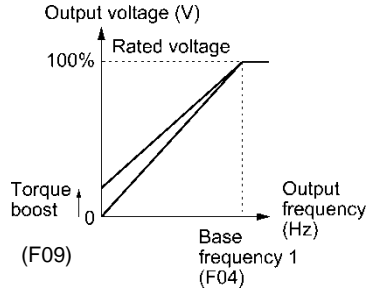

Linear V/f pattern (F37 = 1)

Tip When the variable torque V/f pattern is selected (F37 = 0 or 3), the output voltage may be low at a low frequency zone, resulting in insufficient output torque, depending on the characteristics of the motor and load. In such a case, it is recommended to increase the output voltage at the low frequency zone using the non-linear V/f pattern.

Recommended value: H50 = 1/10 of the base frequency
H51 = 1/10 of the voltage at base frequency

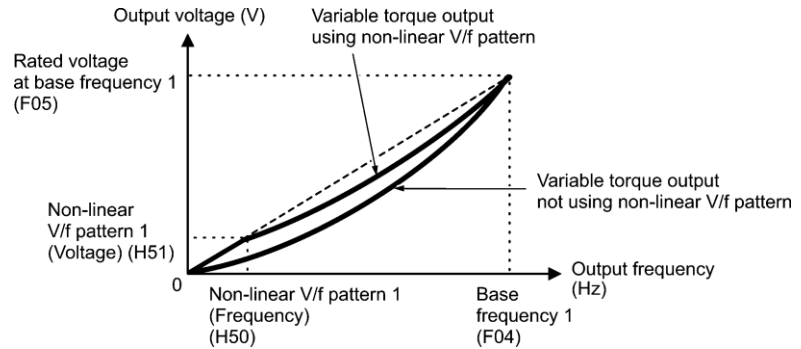

■ **Torque boost** Data setting range: 0.0 to 20.0 (%) (100%/Rated voltage at base frequency)

• **Manual torque boost (F09)**

In torque boost using F09, constant voltage is added to the basic V/f pattern, regardless of the load. To secure a sufficient starting torque, manually adjust the output voltage to optimally match the motor and its load by using F09. Specify an appropriate level that guarantees smooth start-up and yet does not cause over-excitation at no or light load.

Torque boost per F09 ensures high driving stability since the output voltage remains constant regardless of the load fluctuation.

- **Note** Specifying a high torque boost level will generate a high torque, but may cause overcurrent due to over-excitation at no load which can overheat the motor. To avoid this, adjust torque boost to an appropriate level.
- When the non-linear V/f pattern and the torque boost are used together, the torque boost takes effect below the frequency on the non-linear V/f pattern's point.

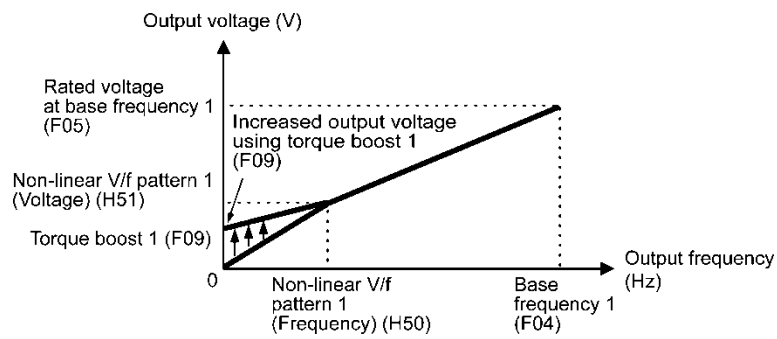

• **Auto torque boost (F37 = 2, 5)**

If the auto torque boost is selected, the inverter automatically optimizes the output voltage to fit the motor with its load. Under light load, the inverter decreases the output voltage to prevent the motor from over-excitation. Under heavy load, it increases the output voltage to increase the output torque of the motor.

- Note**
- Since this function relies also on the characteristics of the motor, set the base frequency 1 (F04), the rated voltage at base frequency 1 (F05), and other pertinent motor parameters (P01 through P03 and P06 through P99) in line with the motor capacity and characteristics, or else perform auto-tuning (P04).
 - When a special motor is driven or the load does not have sufficient rigidity, the maximum torque might decrease or the motor operation might become unstable. In such cases, do not use auto torque boost instead choose manual torque boost per F09 (F37 = 0 or 1).

■ **Auto energy saving operation (H67)**

If the auto energy saving operation is enabled, the inverter automatically controls the supply voltage to the motor to minimize the total power loss of motor and inverter. (Note that this feature may not be effective depending upon the motor or load characteristics. Check the advantage of energy saving before you actually apply this feature to your machinery.)

Select whether applying this feature to constant speed operation only or applying to constant speed operation and accelerating/decelerating operation.

Data for H67	Auto energy saving operation
0	Enable only during running at constant speed
1	Enable during running at constant speed or accelerating/decelerating (Note: For accelerating/decelerating, enable only when the load is light.)

If auto energy saving operation is enabled, the response to a motor speed changes from constant speed operation may be slow. Do not use this feature for machinery that requires quick acceleration/deceleration.

- Note**
- Use auto energy saving only where the base frequency is 60 Hz or lower. If the base frequency is set at 60 Hz or higher, little or no energy saving advantage may result. The auto energy saving operation is designed for use with the frequency lower than the base frequency. If the frequency becomes higher than the base frequency, the auto energy saving operation will be invalid.
 - Since this function relies also on the characteristics of the motor, set the base frequency 1 (F04), the rated voltage at base frequency 1 (F05), and other pertinent motor parameters (P01 through P03 and P06 through P99) in line with the motor capacity and characteristics, or else perform auto-tuning (P04).
 - Under the vector control without speed sensor, the auto energy saving operation is disabled.

F38, F39 Stop frequency (Detection mode, Holding time) (Refer to F23.) see page 4-51

F40, F41 Torque Limiter 1-1, Torque Limiter 1-2 E16, E17 Torque Limiter 2-1, Torque Limiter 2-2
H73 Torque Limiter (Operating conditions)
H76 Torque Limiter (Frequency increment limit for braking)

Under V/f control

If the inverter's output torque exceeds the specified levels of the torque limiters (F40, F41, E16, E17, and E61 to E63), the inverter controls the output frequency and limits the output torque to prevent a stall.

To use the torque limiters, it is necessary to configure the function codes listed in the table on the next page.

- Note**
- In braking, the inverter increases the output frequency to limit the output torque. Depending on the conditions during operation, the output frequency could be excessive. H76 (Frequency increment limit for braking) is provided to limit the increasing frequency component.

Related function codes

Function code	Name	V/f control	Vector control	Remarks
F40	Torque Limiter 1-1	Y	Y	
F41	Torque Limiter 1-2	Y	Y	
E16	Torque Limiter 2-1	Y	Y	
E17	Torque Limiter 2-2	Y	Y	
H73	Torque Limiter (Operating conditions)	Y	Y	
H74	Torque Limiter (Control target)	N	Y	
H75	Torque Limiter (Target quadrants)	N	Y	
H76	Torque Limiter (Frequency increment limit for braking)	Y	N	
E61 to E63	Terminal [12] Extended Function Terminal [C1] Extended Function Terminal [V2] Extended Function	Y	Y	7: Analog torque limit value A 8: Analog torque limit value B

■ Torque limit control mode

Torque limit is performed by limiting torque current flowing across the motor.

The graph below shows the relationship between the torque and the output frequency at the constant torque current limit.

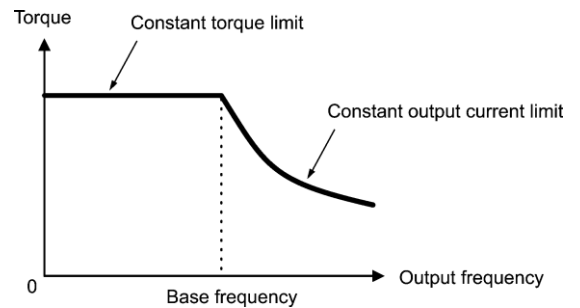

■ Torque limiters 1-1, 1-2, 2-1 and 2-2 (F40, F41, E16 and E17)

Data setting range: -300 to 300 (%), 999 (Disable)

These function codes specify the operation level at which the torque limiters become activated, as the percentage of the motor rated torque.

Function code	Name	Torque limit feature
F40	Torque limiter 1-1	Driving torque current limiter 1
F41	Torque limiter 1-2	Braking torque current limiter 1
E16	Torque limiter 2-1	Driving torque current limiter 2
E17	Torque limiter 2-2	Braking torque current limiter 2



Although the data setting range for F40, F41, E16, and E17 is from positive to negative values (-300% to +300%), specify positive values in practice. Specifying a negative value causes the inverter to interpret it as an absolute value.

The torque limiter determined depending on the overload current actually limits the torque current output. Therefore, the torque current output is automatically limited at a value lower than 300%, the maximum setting value.

■ Analog torque limit values (E61 to E63)

The torque limit values can be specified by analog inputs through terminals [12], [C1], and [V2] (voltage or current). Set E61, E62, and E63 (Terminal [12] Extended Function, Terminal [C1] Extended Function, and Terminal [V2] Extended Function) as listed below.

Data for E61, E62, or E63	Function	Description
7	Analog torque limit value A	Use the analog input as the torque limit value specified by function code data (= 7 or 8). Input specifications: 200% / 10 V or 20 mA
8	Analog torque limit value B	

If the same setting is made for different terminals, the priority order is E61>E62>E63.

■ **Torque limiter levels specified via communications link (S10, S11)**

The torque limiter levels can be changed via the communications link. Function codes S10 and S11 exclusively reserved for the communications link respond to function codes F40 and F41.

■ **Switching torque limiters**

The torque limiters can be switched by the function code setting and the terminal command **TL2/TL1** ("Select torque limiter level 2/1") assigned to any of the digital input terminals.

To assign the **TL2/TL1** as the terminal function, set any of E01 through E07 to "14." If no **TL2/TL1** is assigned, torque limiter levels 1-1 and 1-2 (F40 and F41) take effect by default.

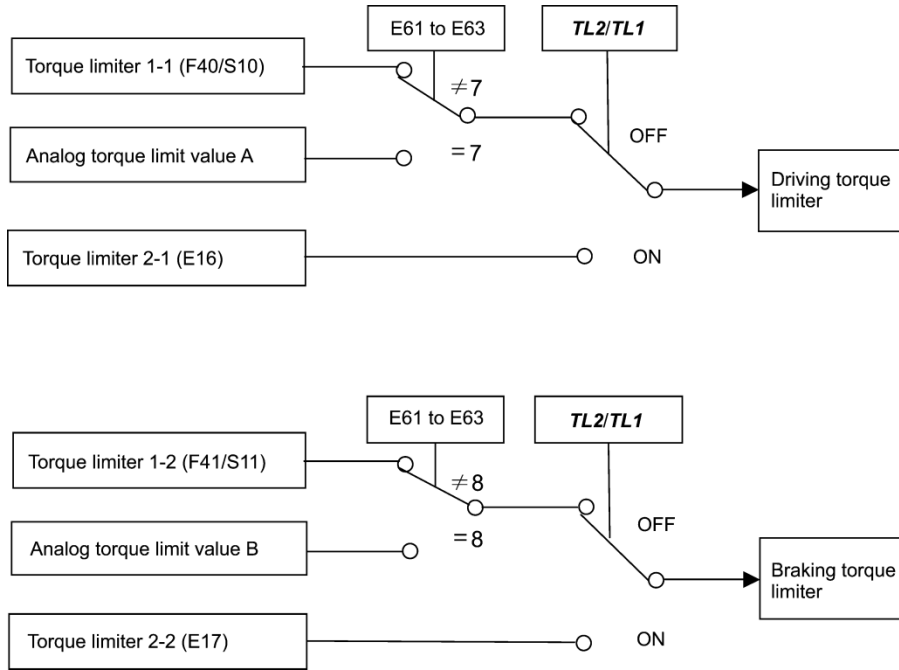

■ **Torque limiter (Operating conditions) (H73)**

H73 specifies whether the torque limiter is enabled or disabled during acceleration/deceleration and running at constant speed.

Data for H73	During accelerating/decelerating	During running at constant speed
0	Enable	Enable
1	Disable	Enable
2	Enable	Disable

■ **Torque limiter (Frequency increment limit for braking) (H76)**

Data setting range: 0.0 to 500.0 (Hz)

H76 specifies the increment limit of the frequency in limiting torque for braking. The factory default is 5.0 Hz. If the increasing frequency during braking reaches the limit value, the torque limiters no longer function, resulting in an overvoltage trip. Such a problem may be avoided by increasing the setting value of H76.

Note The torque limiter and current limiter are very similar in function. If both are activated concurrently, they may conflict with each other and cause hunting (undesirable oscillation of the system). Avoid concurrent activation of these limiters.

Under vector control without/with speed sensor (F42 = 5, 6)

If the inverter's output torque exceeds the specified levels of the torque limiters (F40, F41, E16, E17, and E61 to E63), the inverter controls the speed regulator's output (torque command) in speed control or a torque command in torque control in order to limit the motor-generating torque.

To use the torque limiters, it is necessary to configure the function codes listed in the table below.

Related function codes

Function code	Name	V/f control	Vector control	Remarks
F40	Torque Limiter 1-1	Y	Y	
F41	Torque Limiter 1-2	Y	Y	
E16	Torque Limiter 2-1	Y	Y	
E17	Torque Limiter 2-2	Y	Y	
H73	Torque Limiter (Operating conditions)	Y	Y	
H74	Torque Limiter (Control target)	N	Y	
H75	Torque Limiter (Target quadrants)	N	Y	
H76	Torque Limiter (Frequency increment limit for braking)	Y	N	
E61 to E63	Terminal [12] Extended Function Terminal [C1] Extended Function Terminal [V2] Extended Function	Y	Y	7: Analog torque limit value A 8: Analog torque limit value B

■ Torque Limiter (Control target) (H74)

Under vector control, the inverter can limit motor-generating torque or output power, as well as a torque current (default).

Data for H74	Control target
0	Motor-generating torque limit
1	Torque current limit
2	Output power limit

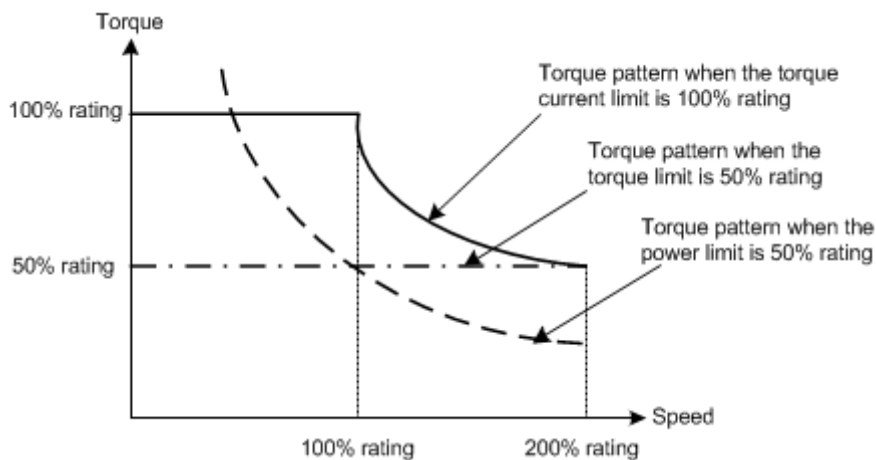

■ **Torque Limiter (Target quadrants) (H75)**

H75 selects the configuration of target quadrants (Drive/brake, Forward/reverse rotation) in which the specified torque limiter(s) is activated, from "Drive/brake torque limit," "Same torque limit for all four quadrants," and "Upper/lower torque limits" shown in the table below.

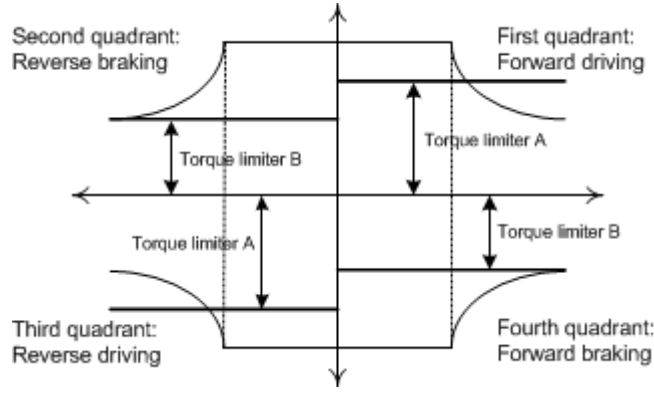
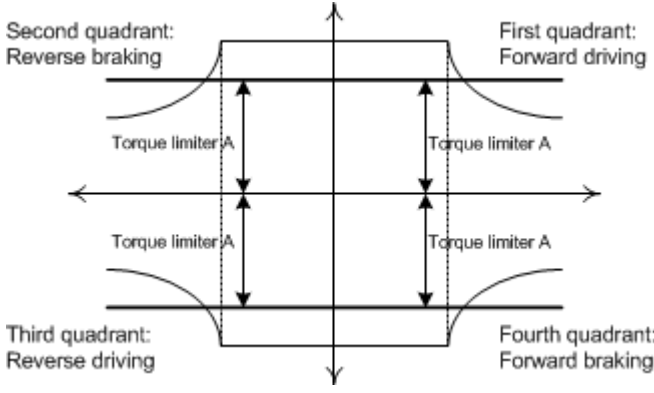
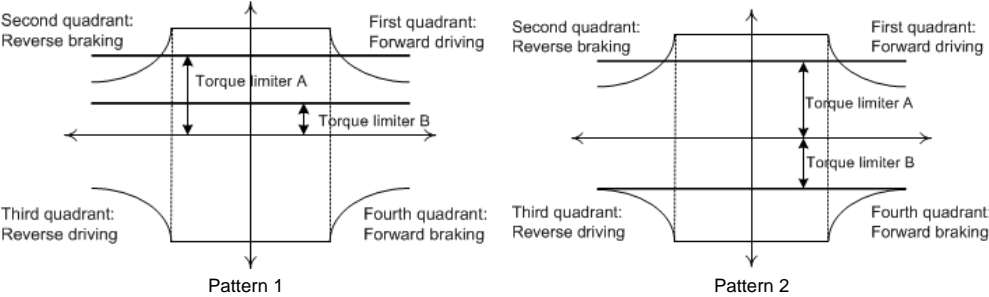
Data for H75	Target quadrants												
0: Drive/brake	<p>Torque limiter A applies to driving (both of forward and reverse), and torque limiter B to braking (both of forward and reverse).</p> 												
1: Same for all four quadrants	<p>Torque limiter A applies to all four quadrants; that is, the same torque limit applies to both driving and braking in the forward and reverse rotations.</p> 												
2: Upper/lower limits	<p>Torque limiter A applies to the upper limit, and torque limiter B to the lower limit. Depending upon the polarity of torque limiters A and B, the following patterns are available.</p> <table border="1" data-bbox="438 1417 1031 1533"> <thead> <tr> <th></th> <th>Torque limiter A</th> <th>Torque limiter B</th> </tr> </thead> <tbody> <tr> <td>Pattern 1</td> <td>Positive</td> <td>Positive</td> </tr> <tr> <td>Pattern 2</td> <td>Positive</td> <td>Negative</td> </tr> <tr> <td>Pattern 3</td> <td>Negative</td> <td>Negative</td> </tr> </tbody> </table> 		Torque limiter A	Torque limiter B	Pattern 1	Positive	Positive	Pattern 2	Positive	Negative	Pattern 3	Negative	Negative
	Torque limiter A	Torque limiter B											
Pattern 1	Positive	Positive											
Pattern 2	Positive	Negative											
Pattern 3	Negative	Negative											

Data for H75	Target quadrants
	<div style="text-align: center;"> <p>Pattern 3</p> </div> <p>Note</p> <ul style="list-style-type: none"> • If the value of torque limiter A is less than that of torque limiter B, torque limiter A applies to both the upper and lower limits. • Selecting the "Upper/lower torque limits" may cause reciprocating oscillation between the upper and lower limit values, depending upon a small difference between the upper and lower limits, a slow response from the speed control sequence, and other conditions.

■ Torque limiters 1-1, 1-2, 2-1 and 2-2 (F40, F41, E16 and E17)

Data setting range: -300 to 300 (%), 999 (Disable)

These function codes specify the operation level at which the torque limiters become activated, as the percentage of the motor rated torque.

Function code	Name
F40	Torque limiter 1-1
F41	Torque limiter 1-2
E16	Torque limiter 2-1
E17	Torque limiter 2-2

Note Although the data setting range for F40, F41, E16, and E17 is from positive to negative values (-300% to +300%), specify positive values in practice except when the "Upper/lower torque limits" (H75 = 2) is selected. Specifying a negative value causes the inverter to interpret it as an absolute value.

The torque limiter determined depending on the overload current actually limits the torque current output. Therefore, the torque current output is automatically limited at a value lower than 300%, the maximum setting value.

■ Analog torque limit values (E61 to E63)

The torque limit values can be specified by analog inputs through terminals [12], [C1], and [V2] (voltage or current). Set E61, E62, and E63 (Terminal [12] Extended Function, Terminal [C1] Extended Function, and Terminal [V2] Extended Function) as listed below.

Data for E61, E62, or E63	Function	Description
7	Analog torque limit value A	Use the analog input as the torque limit value specified by function code data (= 7 or 8). Input specifications: 200% / 10 V or 20 mA
8	Analog torque limit value B	

If the same setting is made for different terminals, the priority order is E61>E62>E63.

■ Torque limiter levels specified via communications link (S10, S11)

The torque limiter levels can be changed via the communications link. Function codes S10 and S11 exclusively reserved for the communications link respond to function codes F40 and F41.

■ Switching torque limiters

The torque limiters can be switched by the function code setting and the terminal command **TL2/TL1** ("Select torque limiter level 2/1") assigned to any of the digital input terminals.

To assign the **TL2/TL1** as the terminal function, set any of E01 through E07 to "14." If no **TL2/TL1** is assigned, torque limiter levels 1-1 and 1-2 (F40 and F41) take effect by default.

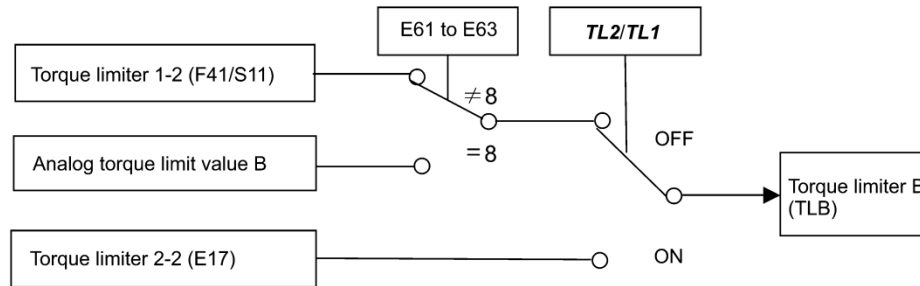
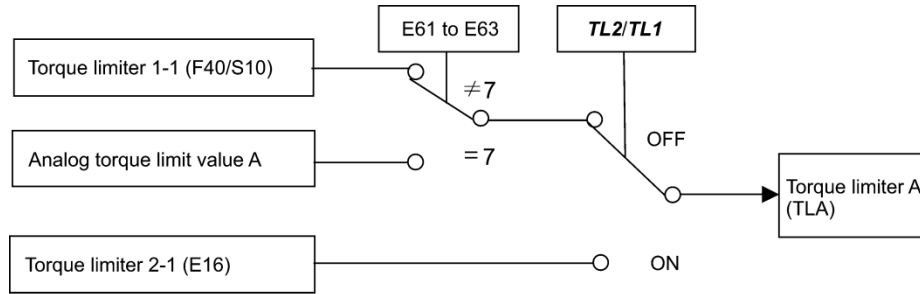

■ **Torque limiter (Operating conditions) (H73)**

H73 specifies whether the torque limiter is enabled or disabled during acceleration/deceleration and running at constant speed.

Data for H73	During accelerating/decelerating	During running at constant speed
0	Enable	Enable
1	Disable	Enable
2	Enable	Disable

Note The torque limiter and current limiter are very similar in function. If both are activated concurrently, they may conflict with each other and cause hunting (undesirable oscillation of the system). Avoid concurrent activation of these limiters.

F42 specifies the motor drive control.

Data for F42	Drive control	Basic control	Speed feedback	Speed control
0	V/f control with slip compensation inactive	V/f control	Disable	Frequency control
1	Dynamic torque control (with slip compensation and auto torque boost)			Frequency control with slip compensation
5	Vector control without speed sensor	Vector control	Estimated speed	Speed control with automatic speed regulator (ASR)
6	Vector control with speed sensor		Enable	

■ V/f control with slip compensation inactive

Under this control, the inverter controls a motor with the voltage and frequency according to the V/f pattern specified by function codes. This control disables all automatically controlled features such as the slip compensation, so no unpredictable output fluctuation occurs, enabling stable operation with constant output frequency.

Note: To active slip compensation, refer to P09~P11 as below. Applying any load to an induction motor causes a rotational slip due to the motor characteristics, decreasing the motor rotation. The inverter's slip compensation function prevents the motor from decreasing the rotation due to the slip. That is, this function is effective for improving the motor speed control accuracy.

Function code	Operation
P12	Rated slip frequency Specify the rated slip frequency.
P09	Slip compensation gain for driving Adjust the slip compensation amount for driving. Slip compensation amount for driving = Rated slip x Slip compensation gain for driving
P11	Slip compensation gain for braking Adjust the slip compensation amount for braking. Slip compensation amount for braking = Rated slip x Slip compensation gain for braking
P10	Slip compensation response time Specify the slip compensation response time. Basically, there is no need to modify the default setting.

To improve the accuracy of slip compensation, perform auto-tuning.

H68 enables or disables the slip compensation function according to the motor driving conditions.

Data for H68	Motor driving conditions		Motor driving frequency zone	
	Accel/Decel	Constant speed	Base frequency or below	Above the base frequency
0	Enable	Enable	Enable	Enable
1	Disable	Enable	Enable	Enable
2	Enable	Enable	Enable	Disable
3	Disable	Enable	Enable	Disable

■ Dynamic torque control

To get the maximal torque out of a motor, this control calculates the motor torque matched to the load applied and uses it to optimize the voltage and current vector output.

Selecting this control automatically enables the auto torque boost and slip compensation function so that it is effective for improving the system response to external disturbances such as load fluctuation, and the motor speed control accuracy.

Note that the inverter may not respond to a rapid load fluctuation since this control is an open-loop V/f control that does not perform current control, unlike vector control. One advantage of this control is that the maximum torque per output current is larger than that of vector control.

■ Vector control without speed sensor

This control estimates the motor speed based on the inverter's output voltage and current to use the estimated speed for speed control. It also decomposes the motor drive current into the exciting and torque current components, and controls each of those components in vector. No PG (pulse generator) interface card is required. It is possible to obtain the desired response by adjusting the control constants (PI constants) using the speed regulator (PI controller).

The control regulating the motor current requires some voltage margin between the voltage that the inverter can output and the induced voltage of the motor. Usually a general-purpose motor is so designed that the voltage matches the commercial power. Under the control, therefore, it is necessary to suppress the motor terminal voltage to the lower level in order to secure the voltage margin required.

However, driving the motor with the motor terminal voltage suppressed to the lower level cannot generate the rated torque even if the rated current originally specified for the motor is applied. To ensure the rated torque, it is necessary to increase the rated current. (This also applies to vector control with speed sensor.)

This control is not available in MD-mode inverters, so do not set F42 data to "5" for those inverters.

■ Vector control with speed sensor

This control requires an optional PG (pulse generator) and an optional PG interface card to be mounted on a motor shaft and an inverter, respectively. The inverter detects the motor's rotational position and speed according to PG feedback signals and uses them for speed control. It also decomposes the motor drive current into the exciting and torque current components, and controls each of components in vector.

It is possible to obtain the desired response by adjusting the control constants (PI constants) using the speed regulator (PI controller).

The control enables speed control with higher accuracy and quicker response than vector control without speed sensor.

 Since slip compensation, dynamic torque control, and vector control with/without speed sensor use motor parameters, the following conditions should be satisfied to obtain full control performance.

- A single motor should be controlled per inverter.
- Motor parameters P02, P03, P06 to P23, P55 and P56 are properly configured. Or, auto-tuning (P04) is performed.
- Under dynamic torque control, the capacity of the motor to be controlled is two or more ratings lower than that of the inverter; under vector control with/without speed sensor, it is the same as that of the inverter. Otherwise, the inverter may not control the motor due to decrease of the current detection resolution.
- The wiring distance between the inverter and motor is 164 ft (50 m) or less. If it is longer, the inverter may not control the motor due to leakage current flowing through stray capacitance to the ground or between wires. Especially, small capacity inverters whose rated current is small may be unable to properly control the motor correctly even when the wiring is less than 164 ft (50 m). In that case, make the wiring length as short as possible or use a wire with small stray capacitance (e.g., loosely-bundled cable) to minimize the stray capacitance.

When the output current of the inverter exceeds the level specified by the current limiter (F44), the inverter automatically manages its output frequency to prevent a stall and limits the output current. The default setting of the current limiter is 130% and 160% for VT and CT mode inverters, respectively. (Once the VT or CT mode is selected by F80, the current limit for each mode is automatically specified.)

Note that for VT and CT mode inverters of 7.5 HP or below, the current limiter is initialized to 160% with F80.

If overload current, 160% (or 130%) or more of the current limit level, flows instantaneously so that an output frequency decrease problem arises due to the current limiter, consider increasing the current limit level.

The current limiter mode should be also selected with F43. If F43 = 1, the current limiter is enabled only during constant speed operation. If F43 = 2, it is enabled during both of acceleration and constant speed operation. Choose F43 = 1 if you need to run the inverter at full capability during acceleration and to limit the output current during constant speed operation.

Mode selection (F43)

F43 selects the motor running state in which the current limiter becomes active.

Data for F43	Running states that enable the current limiter		
	During acceleration	During constant speed	During deceleration
0	Disable	Disable	Disable
1	Disable	Enable	Disable
2	Enable	Enable	Disable

Level (F44) Data setting range: 20 to 200 (%) (in ratio to the inverter rating)

F44 specifies the operation level at which the output current limiter becomes activated, in ratio to the inverter rating.

 Note The inverter's rated current differs depending upon the VT or CT mode selected.

Instantaneous Overcurrent Limiting (Mode selection) (H12)

H12 specifies whether the inverter invokes the current limit processing or enters the overcurrent trip when its output current exceeds the instantaneous overcurrent limiting level. Under the current limit processing, the inverter immediately turns OFF its output gates to suppress the further current increase and continues to control the output frequency.

Data for H12	Function
0	Disable An overcurrent trip occurs at the instantaneous overcurrent limiting level.
1	Enable

If any equipment or machine malfunctions when the motor torque temporarily drops during current limiting processing, it is necessary to cause an overcurrent trip (H12 = 0) and actuate a mechanical brake at the same time.

-  Note
- Since the current limit operation with F43 and F44 is performed by software, it may cause a delay in control. For quick response current limiting, also enable the instantaneous overcurrent limiting with H12.
 - If an excessive load is applied when the current limiter operation level is set extremely low, the inverter will rapidly lower its output frequency. This may cause an overvoltage trip or dangerous turnover of the motor rotation due to undershooting. Depending on the load, extremely short acceleration time may activate the current limiting to suppress the increase of the inverter output frequency, causing the system oscillation (hunting) or activating the inverter overvoltage trip (alarm *Ou*). When specifying the acceleration time, therefore, take into account machinery characteristics and moment of inertia of the load.
 - The torque limiter and current limiter are very similar functions. If both are activated concurrently, they may conflict and cause hunting in the system. Avoid concurrent activation of these limiters.
 - The vector control itself contains the current control system, so it disables the current limiter specified by F43 and F44, as well as automatically disabling the instantaneous overcurrent limiting (specified by H12). Accordingly, the inverter causes an overcurrent trip when its output current exceeds the instantaneous overcurrent limiting level.

**F50 to F52 Electronic Thermal Overload Protection for Braking Resistor
(Discharging capability, Allowable average loss and Resistance)**

These function codes specify the electronic thermal overload protection feature for the braking resistor.

Set the discharging capability, allowable average loss and resistance to F50, F51 and F52, respectively. These values are determined by the inverter and braking resistor models. For the discharging capability, allowable average loss and resistance, check with the manufacturer of the braking resistor and set the function codes accordingly.

Note Depending on the thermal marginal characteristics of the braking resistor, the electronic thermal overload protection feature may act so that the inverter issues the overheat protection alarm *dbH* even if the actual temperature rise is not large enough. If it happens, review the relationship between the performance index of the braking resistor and settings of related function codes.

Tip The standard models of braking resistor can output temperature detection signal for overheat. Assign an "Enable external alarm trip" terminal command **THR** to any of digital input terminals [X1] to [X7], [FWD] and [REV] and connect that terminal and its common terminal to braking resistor's terminals 2 and 1.

Calculating the discharging capability and allowable average loss of the braking resistor and configuring the function code data

When using a braking resistor, check with the resistor manufacturer about the resistor rating and then configure the related function codes.

The calculation procedures for the discharging capability and allowable average loss of the braking resistor differ depending on the application of the braking load as shown below.

- Applying braking load during deceleration

During normal deceleration, the braking load decreases as the speed slows down. In the deceleration with constant torque, the braking load decreases in proportion to the speed. Use equations (1) and (3) given below.

- Applying braking load during running at a constant speed

Different from during deceleration, in applications where the braking load is externally applied during running at a constant speed, the braking load is constant. Use equations (2) and (4) given below.

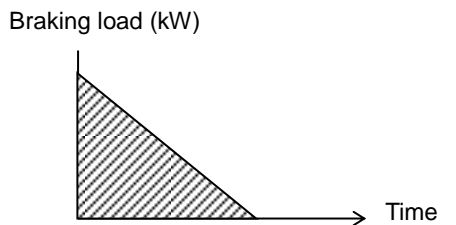

Applying braking load during deceleration

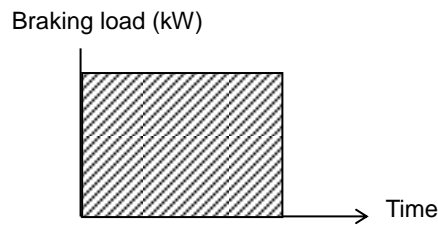

Applying braking load during running at a constant speed

■ Discharging capability (F50)

The discharging capability refers to kW's allowable for a single braking cycle, which is obtained based on the braking time and the motor rated capacity.

Data for F50	Function
0	To be applied to the braking resistor built-in type
1 to 9000	1 to 9000 (kW's)
OFF	Disable the electronic thermal overload protection

During deceleration:

$$\text{Discharging capability (kW's)} = \frac{\text{Braking time (s)} \times \text{Motor rated capacity (HP)} \times 0.75}{2}$$

Equation (1)

During running at a constant speed:

$$\text{Discharging capability (kW's)} = \text{Braking time (s)} \times \text{Motor rated capacity (HP)} \times 0.75$$

Equation (2)

Tip When the F50 data is set to "0" (To be applied to the braking resistor built-in type), no specification of the discharging capability is required.

■ **Allowable average loss (F51)**

The allowable average loss refers to a tolerance for motor continuous operation, which is obtained based on the %ED (%) and motor rated capacity (HP).

Data for F51	Function
0.001 to 99.99	0.001 to 99.99 (kW)

During deceleration:

$$\text{Allowable average loss (kW)} = \frac{\%ED(\%) \div 100 \times \text{Motor rated capacity (HP)} \times 0.75}{2}$$

Equation (3)

During constant speed operation:

$$\text{Allowable average loss (kW)} = \frac{\%ED(\%) \div 100 \times \text{Motor rated capacity (HP)} \times 0.75}{2}$$

Equation (4)

■ **Resistance (F52)**

F52 specifies the resistance of the braking resistor.

F80 Switching between LD, MD and HD drive modes

F80 specifies whether to drive the inverter in the low duty (LD), medium duty (MD), or high duty (HD) mode as described below.

To change the F80 data, it is necessary to press the "STOP" + "▲" keys" or "STOP" + "▼" keys" (simultaneously keying).

F80 data	Drive mode	Application	Continuous rated current level	Overload capability	Maximum frequency
1	LD (Variable Torque) mode	Light load	Drive a motor whose capacity is the <u>same</u> as the inverter's one.	120% for 1 min.	120 Hz
2	MD (Constant Torque) mode	Medium load	Drives a motor whose capacity is the <u>same</u> as the inverter's one or derates a motor <u>one rank lower</u> than the inverter's capacity.	150% for 1 min.	120 Hz
0	HD (CT-Vector) mode	Heavy load	Derates a motor <u>one or two ranks lower</u> than the inverter's capacity.	150% for 1 min. 200% for 3 s	500 Hz

Switching to the MD/HD mode increases the overload capability (%) against the continuous current level up to 150%, but it requires derating the motor one or two ranks lower than the inverter's capacity.

Note: For 7.5 HP or smaller, when LD mode is selected, the HD mode specification applies.

For the rated current level, see Chapter 11 "SPECIFICATIONS."

The LD/MD-mode inverter is subject to restrictions on the function code data setting range and internal processing as listed below.

Function codes	Name	Variable Torque	Constant Torque	CT-Vector	Remarks
F21*	DC braking (Braking level)	Setting range: 0 to 80%		Setting range: 0 to 100%	In the LD/MD mode, a value out of the range, if specified, automatically changes to the maximum value allowable in the LD mode.
F26	Motor sound (Carrier frequency)	Setting range: 0.75 to 16 kHz (0.5 to 30 HP) 0.75 to 10 kHz (40 to 100 HP) 0.75 to 6 kHz (125 to 900 HP) 0.75 to 4 kHz (1000 HP)	Setting range: 0.75 to 2 kHz (125 to 700 HP)	Setting range: 0.75 to 16 kHz (0.5 to 125 HP) 0.75 to 10 kHz (125 to 700 HP) 0.75 to 6 kHz (800 and 900 HP)	
F44	Current limiter (Level)	Initial value: 130%	Initial value: 145%	Initial value: 160%	Switching the drive mode with function code F80 automatically initializes the F44 data to the value specified at left.
F03*	Maximum frequency	Setting range: 25 to 500 Hz Upper limit: 120 Hz		Setting range: 25 to 500 Hz Upper limit: 500 Hz	In the variable/constant torque mode, if the maximum frequency exceeds 120 Hz, the actual output frequency is internally limited to 120 Hz.
—	Current indication and output	Based on the rated current level for variable torque mode	Based on the rated current level for constant torque mode	Based on the rated current level for CT-Vector mode	—

Even switching to the Variable/Constant Torque mode cannot automatically change the motor rated capacity (P02*), so configure the P02* data to match the applied motor rating as required.

4.2.2 E codes (Extension Terminal Functions)

E01 to E07 Terminal [X1] to [X7] Function

E98 (Terminal [FWD] Function)
E99 (Terminal [REV] Function)

E01 to E07, E98 and E99 assign commands (listed below) to general-purpose, programming, digital input terminals, [X1] to [X7], [FWD], and [REV].

These function codes can also switch the logic system between normal and negative to define how the inverter logic interprets the ON or OFF state of each terminal. The factory default setting is normal logic system "Active ON." So, descriptions that follow are given in normal logic system. They are, in principle, arranged in the numerical order of assigned data. However, highly relevant signals are collectively described where one of them first appears. Refer to the function codes in the "Related function codes" column, if any.

The EQ7 runs under "V/f control," "dynamic torque control," "vector control without speed sensor," or "vector control with speed sensor." Some terminal commands assigned apply exclusively to the specific drive control, which is indicated by letters Y (Applicable) and N (Not applicable) in the "Drive control" column in the table given below. (Refer to page 4-2.)

⚠ CAUTION

- Ensure safety before modifying the function code settings.
Run commands (e.g., "Run forward" **FWD**), stop commands (e.g., "Coast to a stop" **BX**), and frequency change commands can be assigned to digital input terminals. Depending upon the assignment states of those terminals, modifying the function code setting may cause a sudden motor start or an abrupt change in speed.
- When the inverter is controlled with the digital input signals, switching run or frequency command sources with the related terminal commands (e.g., **SS1**, **SS2**, **SS4**, **SS8**, **Hz2/Hz1**, **Hz/PID**, **IVS**, and **LE**) may cause a sudden motor start or an abrupt change in speed.
An accident or physical injury may result.

Function code data		Terminal commands assigned	Symbol	Drive control				Related function codes
Active ON	Active OFF			V/f	w/o PG	w/ PG	Torque control	
0	1000	Select multi-frequency (0 to 15 steps)	SS1	Y	Y	Y	N	C05 to C19
1	1001		SS2	Y	Y	Y	N	
2	1002		SS4	Y	Y	Y	N	
3	1003		SS8	Y	Y	Y	N	
4	1004	Select ACC/DEC time (2 steps)	RT1	Y	Y	Y	N	F07, F08, E10 to E15
5	1005	Select ACC/DEC time (4 steps)	RT2	Y	Y	Y	N	
6	1006	Enable 3-wire operation	HLD	Y	Y	Y	Y	F02
7	1007	Coast to a stop	BX	Y	Y	Y	Y	—
8	1008	Reset alarm	RST	Y	Y	Y	Y	—
1009	9	Enable external alarm trip	THR	Y	Y	Y	Y	—
10	1010	Ready for jogging	JOG	Y	Y	Y	N	C20, H54, H55, d09 to d13
11	1011	Select frequency command 2/1	Hz2/Hz1	Y	Y	Y	N	F01, C30
12	1012	Select motor 2	M2	Y	Y	Y	Y	A42
13	—	Enable DC braking	DCBRK	Y	Y	Y	N	F20 to F22
14	1014	Select torque limiter level 2/1	TL2/TL1	Y	Y	Y	Y	F40, F41, E16, E17
15	—	Switch to commercial power (50 Hz)	SW50	Y	N	N	N	—
16	—	Switch to commercial power (60 Hz)	SW60	Y	N	N	N	—
17	1017	UP (Increase output frequency)	UP	Y	Y	Y	N	Frequency command: F01, C30 PID command: J02
18	1018	DOWN (Decrease output frequency)	DOWN	Y	Y	Y	N	
19	1019	Enable data change with keypad	WE-KP	Y	Y	Y	Y	F00
20	1020	Cancel PID control	Hz/PID	Y	Y	Y	N	J01 to J19, J56 to J62
21	1021	Switch normal/inverse operation	IVS	Y	Y	Y	N	C53, J01

Function code data		Terminal commands assigned	Symbol	Drive control				Related function codes
Active ON	Active OFF			V/f	w/o PG	w/ PG	Torque control	
22	1022	Interlock	IL	Y	Y	Y	Y	F14
23	1023	Cancel torque control	HZ/TRQ	N	N	N	Y	H18
24	1024	Enable communications link via RS-485 or fieldbus (option)	LE	Y	Y	Y	Y	H30, y98
25	1025	Universal DI	U-DI	Y	Y	Y	Y	—
26	1026	Enable auto search for idling motor speed at starting	STM	Y	Y	N	Y	H09, <u>d67</u>
30	1030	Force to stop	STOP	Y	Y	Y	Y	F07, H56
32	1032	Pre-excitation	EXITE	N	Y	Y	N	H84, H85
33	1033	Reset PID integral and differential components	PID-RST	Y	Y	Y	N	J01 to J19, J56 to J62
34	1034	Hold PID integral component	PID-HLD	Y	Y	Y	N	
35	1035	Select local (keypad) operation	LOC	Y	Y	Y	Y	(See Section 4.2.2.)
39	—	Protect motor from dew condensation	DWP	Y	Y	Y	Y	J21
40	—	Enable integrated sequence to switch to commercial power (50 Hz)	ISW50	Y	N	N	N	J22
41	—	Enable integrated sequence to switch to commercial power (60 Hz)	ISW60	Y	N	N	N	
47	1047	Servo-lock command	LOCK	N	N	Y	N	J97 to J99
48	—	Pulse train input (available only on terminal [X7])	PIN	Y	Y	Y	Y	F01, C30, d62, d63
49	1049	Pulse train sign (available on terminals except [X7])	SIGN	Y	Y	Y	Y	
59	1049	Enable battery operation	BATRY	Y	Y	Y	Y	
70	1070	Cancel constant peripheral speed control	HZ/LSC	Y	Y	Y	N	d41
71	1071	Hold the constant peripheral speed control frequency in the memory	LSC-HLD	Y	Y	Y	N	
72	1072	Count the run time of commercial power-driven motor 1	CRUN-M1	Y	N	N	Y	H44, H94
73	1073	Count the run time of commercial power-driven motor 2	CRUN-M2	Y	N	N	Y	
76	1076	Select droop control	DROOP	Y	Y	Y	N	H28
77	1077	Cancel PG alarm	PG-CCL	N	N	Y	Y	—
98	—	Run forward (Exclusively assigned to [FWD] and [REV] terminals by E98 and E99)	FWD	Y	Y	Y	Y	<u>F02</u>
99	—	Run reverse (Exclusively assigned to [FWD] and [REV] terminals by E98 and E99)	REV	Y	Y	Y	Y	
100	—	No function assigned	NONE	Y	Y	Y	Y	U81 to U85

Note Some negative logic (Active OFF) commands cannot be assigned to the functions marked with "—" in the "Active OFF" column.

The "Enable external alarm trip" (data = 1009) and "Force to stop" (data = 1030) are fail-safe terminal commands. In the case of "Enable external alarm trip," when data = 1009, "Active ON" (alarm is triggered when ON); when data = 9, "Active OFF" (alarm is triggered when OFF).

Terminal function assignment and data setting

■ Multi-frequency (0 to 15 steps) --SS1, SS2, SS4, SS8 (Function code data = 0 to 3)

The combination of the ON/OFF states of digital input signals **SS1**, **SS2**, **SS4** and **SS8** selects one of 16 different frequency commands defined beforehand by 15 function codes C05 to C19 (Multi-frequency 0 to 15). With this, the inverter can drive the motor at 16 different preset frequencies. 📖 Refer to C05 through C19.

■ Acceleration / deceleration time --RT1, RT2 (Function code data = 4 and 5)

Selects acceleration / deceleration times using terminal functions, see page 4-38.

■ Enable 3-wire operation --HLD (Function code data = 6)

Turning this terminal command ON self-holds the forward **FWD** or reverse **REV** run command, to enable 3-wire inverter operation. 📖 Refer to F02.

■ Coast to a stop --BX (Function code data = 7)

Turning this terminal command ON immediately shuts down the inverter output so that the motor coasts to a stop without issuing any alarms.

■ Reset alarm --RST (Function code data = 8)

Turning this terminal command ON clears the **ALM** state--alarm output (for any fault). Turning it OFF erases the alarm display and clears the alarm hold state.

When activating the **RST** command ON, keep it ON for 10 ms or more. This command should be kept OFF for the normal inverter operation.

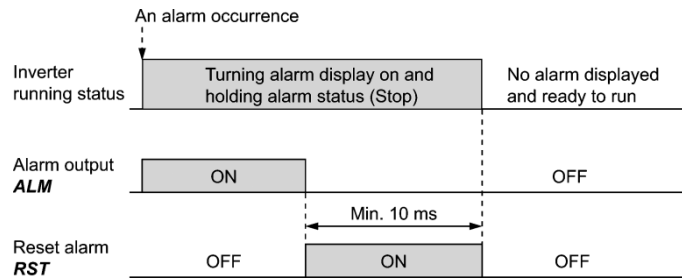

■ Enable external alarm trip --THR (Function code data = 9)

Turning this terminal command OFF immediately shuts down the inverter output (so that the motor coasts to a stop), displays the alarm *Oh2*, and outputs the alarm relay (for any fault) **ALM**. The **THR** command is self-held, and is reset when an alarm reset takes place.

 **Tip** Use this alarm trip command from external equipment when immediately shutting down the inverter output in the event of an abnormal situation in peripheral equipment.

■ Ready for jogging --JOG (Function code data = 10)

This terminal command is used to jog or inch the motor for positioning a work piece. Turning this command ON makes the inverter ready for jogging. 📖 Refer to C20.

■ Select frequency command 2/1 --Hz2/Hz1 (Function code data = 11)

Turning this terminal command ON and OFF switches the frequency command source between frequency command 1 (F01) and frequency command 2 (C30). 📖 Refer to F01.

■ Select motor 2 --M2 (Function code data = 12)

The combination of digital input terminal commands **M2**, **M3** and **M4** switches to any of the 1st to 4th motors. When the motor is switched, the function code group with which the inverter drives the motor is also switched to the one corresponding to the motor. 📖 Refer to A42.

■ **Enable DC braking -- *DCBRK* (Function code data = 13)**

This terminal command gives the inverter a DC braking command through the inverter's digital input. (Requirements for DC braking must be satisfied.) 📖 Refer to F20 through F22.

■ **Select torque limiter level 2/1 -- *TL2/TL1* (Function code data = 14)**

This terminal command switches between torque limiter 1 (F40 and F41) and torque limiter 2 (E16 and E17). 📖 Refer to F40 and F41.

■ **Switch to commercial power for 50 Hz or 60 Hz -- *SW50* and *SW60* (Function code data = 15 and 16)**

When an external sequence switches the motor drive power from the commercial line to the inverter, inputting the terminal command ***SW50*** or ***SW60*** at the specified timing enables the inverter to start running the motor with the current commercial power frequency, regardless of settings of the reference/output frequency in the inverter. A running motor driven by commercial power is carried on into inverter operation. This command smoothly switches the motor drive power source, when the motor is being driven by commercial power, from the commercial power to the inverter power.

For details, refer to the following table, the operation schemes, and an example of external circuit and its operation time scheme on the following pages.

Assignment	The inverter:	Description
<i>SW50</i>	Starts at 50 Hz.	Do not concurrently assign both <i>SW50</i> and <i>SW60</i> .
<i>SW60</i>	Starts at 60 Hz.	

Operation Schemes

- When the motor speed remains almost the same during coast-to-stop:

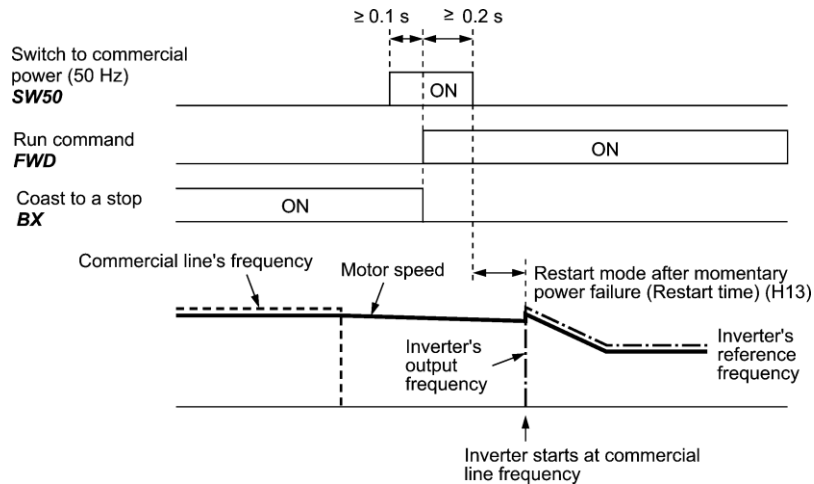

- When the motor speed decreases significantly during coast-to-stop (with the current limiter activated):

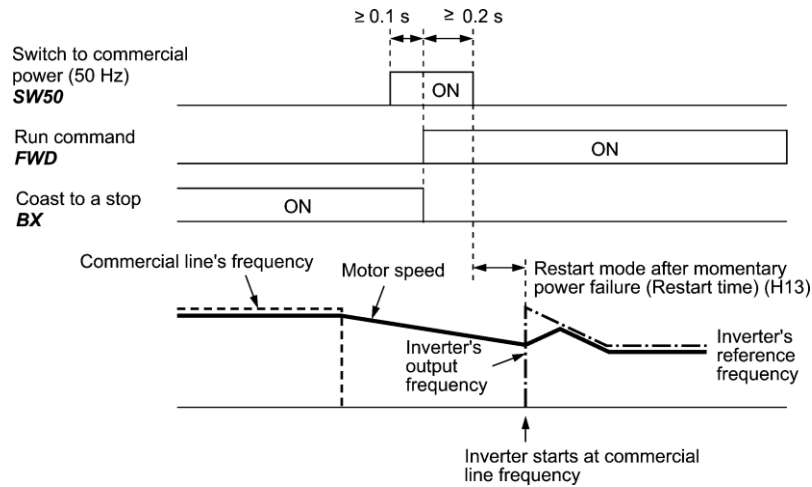

- Note**
- Secure more than 0.1 second after turning ON the "Switch to commercial power" signal before turning ON a run command.
 - Secure more than 0.2 second of an overlapping period with both the "Switch to commercial power" signal and run command being ON.
 - If an alarm has been issued or **BX** has been ON when the motor drive source is switched from the commercial power to the inverter, the inverter will not be started at the commercial power frequency and will remain OFF. After the alarm has been reset or **BX** turned OFF, operation at the frequency of the commercial power will not be continued, and the inverter will be started at the ordinary starting frequency.
- To switch the motor drive source from the commercial line to the inverter, be sure to turn **BX** OFF before the "Switch to commercial power" signal is turned OFF.
- When switching the motor drive source from the inverter to commercial power, adjust the inverter's reference frequency at or slightly higher than that of the commercial power frequency beforehand, taking into consideration the motor speed down during the coast-to-stop period produced by switching.
 - Note that when the motor drive source is switched from the inverter to the commercial power, a high inrush current will be generated, because the phases of the commercial power usually do not match the motor speed at the switching. Make sure that the power supply and all the peripheral equipment are capable of withstanding this inrush current.
 - If "Restart after momentary power failure" (F14 = 3, 4, or 5), is activated keep **BX** ON during commercial power driven operation to prevent the inverter from restarting after a momentary power failure.

Example of Sequence Circuit

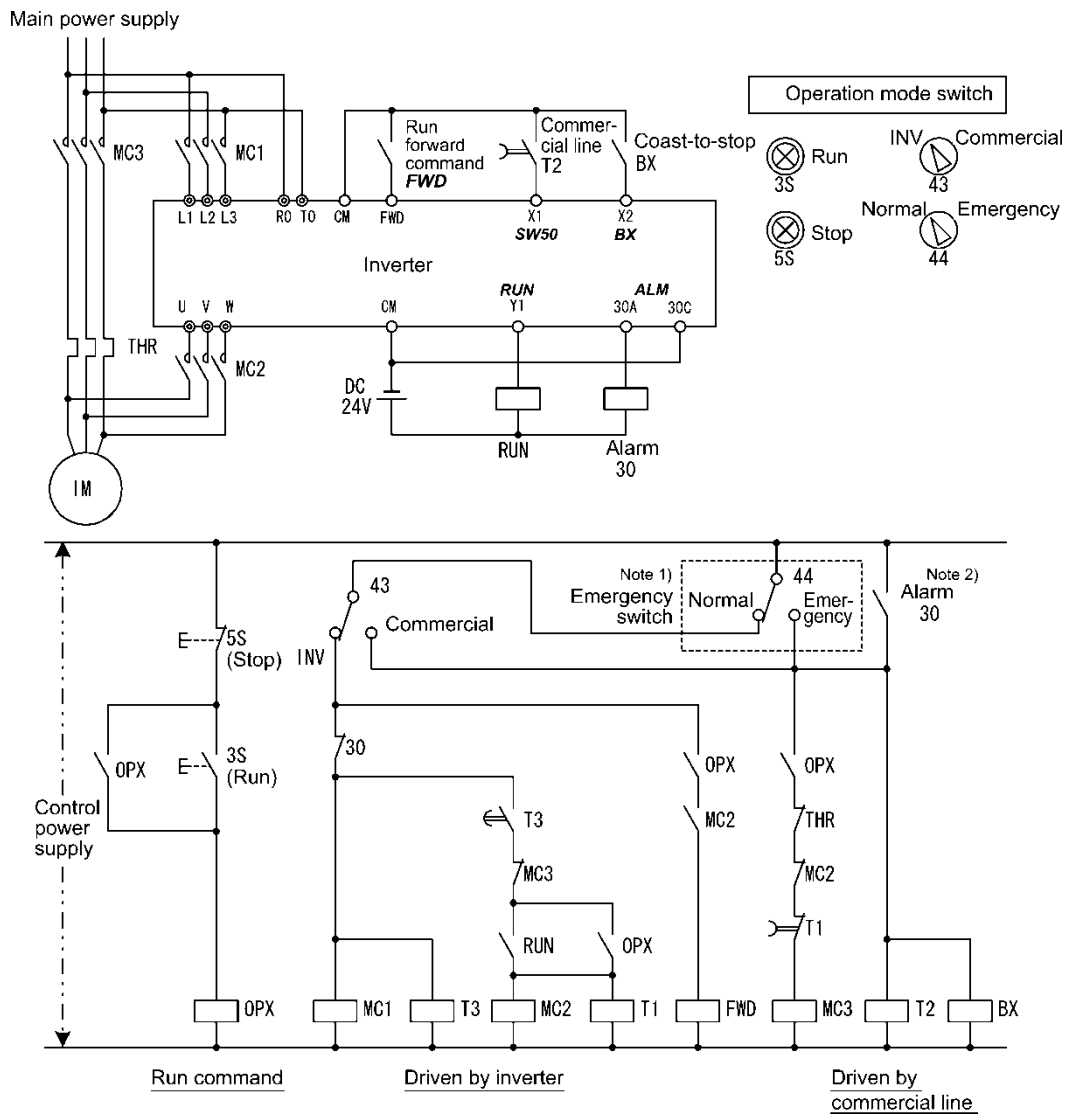

Note 1) Emergency switch

Manual switch provided for the event that the motor drive source cannot be switched normally to the commercial power due to a serious problem of the inverter

Note 2) When any alarm has occurred inside the inverter, the motor drive source will automatically be switched to the commercial power.

Example of Operation Time Scheme

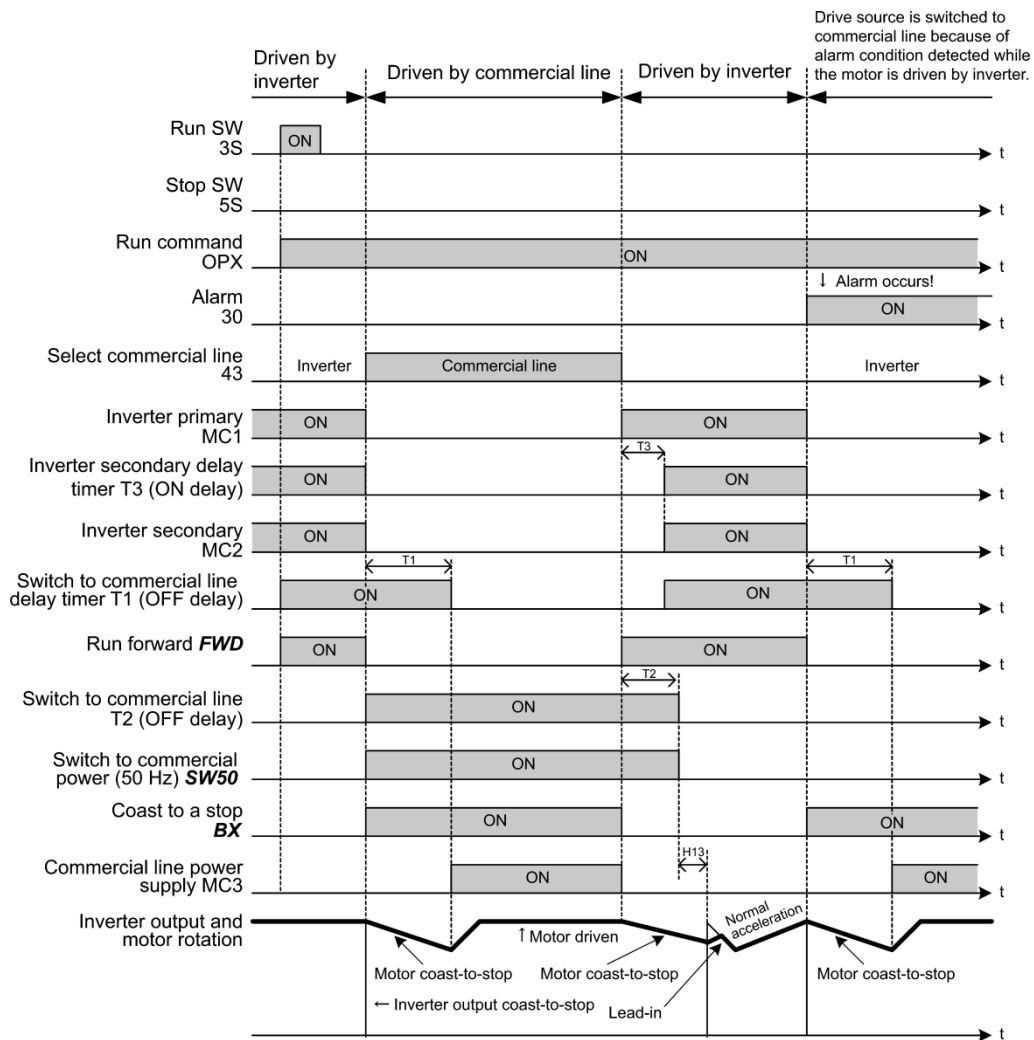

Tip Alternatively, set the integrated sequence by which some of the actions above are automatically performed by the inverter itself. For details, refer to the description of **ISW50** and **ISW60**.

■ UP (Increase output frequency) and DOWN (Decrease output frequency) commands -- UP and DOWN (Function code data = 17 and 18)

• Frequency setting

Turning the terminal command **UP** or **DOWN** ON causes the output frequency to increase or decrease, respectively, within the range from 0 Hz to the maximum frequency. Refer to F01 (data = 7).

• PID command

Turning the terminal command **UP** or **DOWN** ON causes the PID command value to increase or decrease, respectively, within the range from 0 to 100%. Refer to J02 (data = 3).

■ Enable data change with keypad PID control -- WE-KP (Function code data = 19)

Turning the terminal command **WE-KP** OFF protects function code data from accidentally getting changed by pressing the keys on the keypad. Only when this terminal command is ON, you can change function code data from the keypad. Refer to F00.

■ **Cancel PID control -- Hz/PID (Function code data = 20)**

Turning this terminal command ON disables the PID control.

If the PID control is disabled with this command, the inverter runs the motor with the reference frequency manually set by any of the multi-frequency, keypad, analog input, etc.

Terminal command <i>Hz/PID</i>	Function
OFF	Enable PID control
ON	Disable PID control/Enable manual frequency settings

(📖 Refer to the descriptions of J01 through J19 and J56 through J62.)

■ **Switch normal/inverse operation -- IVS (Function code data = 21)**

This terminal command switches the output frequency control between normal (proportional to the input value) and inverse in analog frequency setting or under PID process control. To select the inverse operation, turn the *IVS* ON.

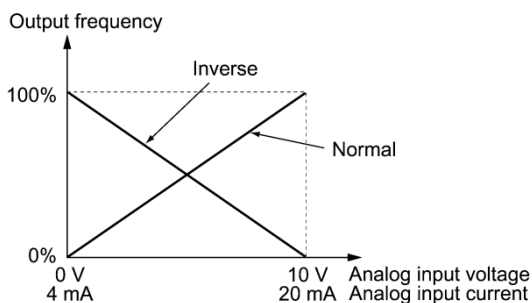

Tip The normal/inverse switching operation is useful for air-handling that require switching between cooling and heating. In cooling, the speed of the fan motor (output frequency of the inverter) is increased to lower the temperature. In heating, it is reduced to lower the temperature. This switching is realized by this *IVS* terminal command.

• **When the inverter is driven by an external analog frequency command sources (terminals [12], [C1] and [V2]):**

Switching normal/inverse operation can apply only to the analog frequency command sources (terminals [12], [C1] and [V2]) in frequency command 1 (F01) and does not affect frequency command 2 (C30) or UP/DOWN control.

As listed below, the combination of the "Selection of normal/inverse operation for frequency command 1" (C53) and the *IVS* terminal command determines the final operation.

Combination of C53 and *IVS*

Data for C53	<i>IVS</i>	Final operation
0: Normal operation	OFF	Normal
	ON	Inverse
1: Inverse operation	OFF	Inverse
	ON	Normal

• **When the process control is performed by the PID processor integrated in the inverter:**

The terminal command *Hz/PID* ("Cancel PID control") can switch the PID control between enabled (process is to be controlled by the PID processor) and disabled (process is to be controlled by the manual frequency setting). In either case, the combination of the "PID control" (J01) or "Selection of normal/inverse operation for frequency command 1" (C53) and the terminal command *IVS* determines the final operation as listed below.

When the PID control is enabled:

The normal/inverse operation selection for the PID processor output (reference frequency) is as follows.

PID control (Mode selection) (J01)	<i>IVS</i>	Final operation
1: Enable (normal operation)	OFF	Normal
	ON	Inverse
2: Enable (inverse operation)	OFF	Inverse
	ON	Normal

When the PID control is disabled:

The normal/inverse operation selection for the manual reference frequency is as follows.

Selection of normal/inverse operation for frequency command 1 (C53)	<i>IVS</i>	Final operation
0: Normal operation	–	Normal
1: Inverse operation	–	Inverse

Note When the process control is performed by the PID control facility integrated in the inverter, the *IVS* is used to switch the PID processor output (reference frequency) between normal and inverse, and has no effect on any normal/inverse operation selection of the manual frequency setting.

Refer to the descriptions of J01 through J19 and J56 through J62.

■ Interlock -- *IL* (Function code data = 22)

In a configuration where a magnetic contactor (MC) is installed in the power output (secondary) circuit of the inverter, the momentary power failure detection feature provided inside the inverter may not be able to accurately detect a momentary power failure by itself. Using a digital signal input with the interlock command *IL* assures the accurate detection. Refer to F14.

Terminal command <i>IL</i>	Meaning
OFF	No momentary power failure has occurred.
ON	A momentary power failure has occurred. (Restart after a momentary power failure enabled)

■ Cancel torque control -- *Hz/TRQ* (Function code data = 23)

When torque control is enabled (H18 = 2 or 3), assigning the terminal command *Hz/TRQ* ("Cancel torque control") to any of the general-purpose digital input terminals (data = 23) enables switching between speed control and torque control.

Cancel torque control signal <i>Hz/TRQ</i>	Operation
ON	Cancel torque control (Enable speed control)
OFF	Enable torque control

■ Enable communications link via RS-485 or fieldbus (option) -- *LE* (Function code data = 24)

Turning this terminal command ON gives priorities to frequency commands or run commands received via the RS-485 communications link (H30) or the fieldbus option (y98). No *LE* assignment is functionally equivalent to the *LE* being ON. Refer to H30 (Communications link function) and y98 (Bus link function).

■ Universal DI -- *U-DI* (Function code data = 25)

Using *U-DI* enables the inverter to monitor digital signals sent from the peripheral equipment via an RS-485 communications link or a fieldbus option by feeding those signals to the digital input terminals. Signals assigned to the universal DI are simply monitored and do not operate the inverter.

For an access to universal DI via the RS-485 or fieldbus communications link, refer to their respective Instruction Manuals.

■ Enable auto search for idling motor speed at starting -- *STM* (Function code data = 26)

This digital terminal command determines, at the start of operation, whether or not to search for idling motor speed and follow it. Refer to H09 (Starting mode).

■ **Force to stop -- STOP (Function code data = 30)**

Turning this terminal command OFF causes the motor to decelerate to a stop in accordance with the H56 data (Deceleration time for forced stop). After the motor stops, the inverter enters the alarm state with the alarm *er6* displayed. (Refer to the description of F07.)

■ **Pre-excitation -- EXITE (Function code data = 32)**

Turning this terminal command ON activates the pre-exciting feature. Even if this pre-excitation command is not assigned, specifying H85 (Pre-excitation: Time) to other than "0.00" enables the inverter to automatically start pre-exciting of the motor when it is turned ON. (This applies exclusively to the inverters under vector control with speed sensor.) (Refer to H84 and H85.)

■ **Reset PID integral and differential components -- PID-RST (Function code data = 33)**

Turning this terminal command ON resets the integral and differential components of the PID processor. (Refer to the descriptions of J01 through J19 and J56 through J62.)

■ **Hold PID integral component -- PID-HLD (Function code data = 34)**

Turning this terminal command ON holds the integral components of the PID processor. (Refer to the descriptions of J01 through J19 and J56 through J62.)

■ **Select local (keypad) operation -- LOC (Function code data = 35)**

This terminal command switches the sources of run and frequency commands between remote and local.

(Refer to details of switching between remote and local modes, refer to Chapter 7, Section 7.3.6 "Switching between remote and local modes.")

■ **Protect motor from dew condensation -- DWP (Function code data = 39)**

Turning this terminal command ON supplies a DC current to the motor in a stopped state in order to generate heat, preventing dew condensation. (Refer to J21.)

■ **Enable integrated sequence to switch to commercial power (50 Hz) and (60 Hz) -- ISW50 and ISW60 (Function code data = 40 and 41)**

With the terminal command *ISW50* or *ISW60* assigned, the inverter controls the magnetic contactor that switches the motor drive source between the commercial power and the inverter output according to the integrated sequence.

This control is effective when not only *ISW50* or *ISW60** has been assigned to the input terminal but also the *SW88* and *SW52-2* signals have been assigned to the output terminals. (It is not essential to assign the *SW52-1* signal.)

* The *ISW50* or *ISW60* should be selected depending upon the frequency of the commercial power; the former for 50 Hz and the latter for 60 Hz.

For details of these commands, refer to the circuit diagrams and timing schemes given below.

Terminal command assigned	Operation (Switching from commercial power to inverter)
<i>ISW50</i> Enable integrated sequence to switch to commercial power (50 Hz)	Start at 50 Hz.
<i>ISW60</i> Enable integrated sequence to switch to commercial power (60 Hz)	Start at 60 Hz.

NOTE Do not assign both *ISW50* and *ISW60* at the same time. Doing so cannot guarantee the result.

Circuit Diagram and Configuration

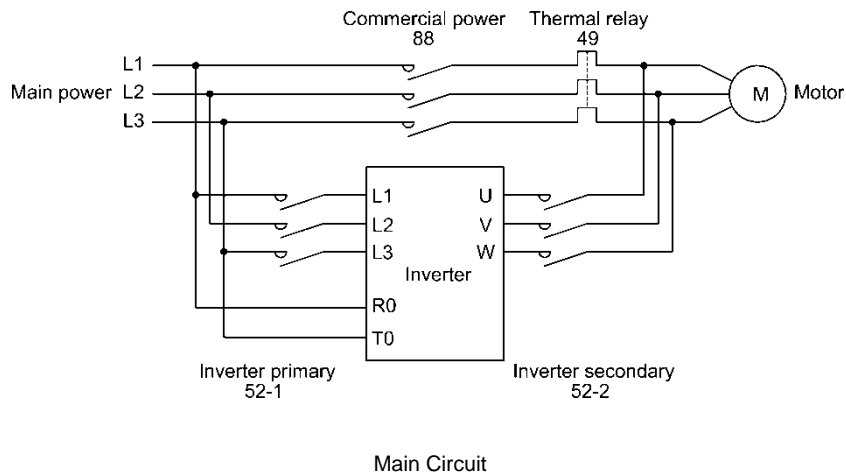

an overcurrent flow opens this relay.

Configuration of Control Circuit

Summary of Operation

Input		Output (Status signal and magnetic contactor)			Inverter operation
<i>ISW50</i> or <i>ISW60</i>	Run command	SW52-1 52-1	SW52-2 52-2	SW88 88	
OFF (Commercial power)	ON	OFF	OFF	ON	OFF
	OFF	OFF	OFF	OFF	
ON (Inverter)	ON	ON	ON	OFF	ON
	OFF	ON	ON	OFF	OFF

Timing Scheme

Switching from inverter operation to commercial-power operation *ISW50/ISW60*: ON → OFF

- (1) The inverter output is shut OFF immediately (Power gate IGBT OFF)
- (2) The inverter primary circuit **SW52-1** and the inverter secondary side **SW52-2** are turned OFF immediately.
- (3) If a run command is present after an elapse of t1 (0.2 sec + time specified by H13), the commercial power circuit **SW88** is turned ON.

Switching from commercial-power operation to inverter operation **ISW50/ISW60**: OFF → ON

- (1) The inverter primary circuit **SW52-1** is turned ON immediately.
- (2) The commercial power circuit **SW88** is turned OFF immediately.
- (3) After an elapse of t_2 (0.2 sec + time required for the main circuit to get ready) from when **SW52-1** is turned ON, the inverter secondary circuit **SW52-2** is turned ON.
- (4) After an elapse of t_3 (0.2 sec + time specified by H13) from when **SW52-2** is turned ON, the inverter synchronizes once the motor that has been freed from the commercial power to the commercial power frequency. Then the motor returns to the operation driven by the inverter.

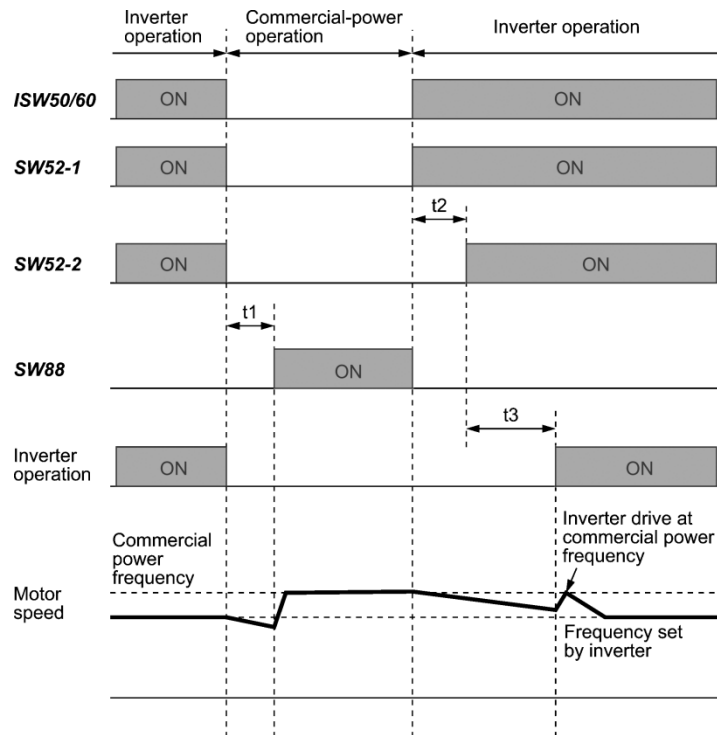

- t_1 : 0.2 sec + Time specified by H13 (Restart mode after momentary power failure)
- t_2 : 0.2 sec + Time required for the main circuit to get ready
- t_3 : 0.2 sec + Time specified by H13 (Restart mode after momentary power failure)

Selection of Commercial Power Switching Sequence

J22 specifies whether or not to automatically switch to commercial-power operation when an inverter alarm occurs.

Data for J22	Sequence (upon occurrence of an alarm)
0	Keep inverter-operation (Stop due to alarm.)
1	Automatically switch to commercial-power operation

- Note**
- The sequence operates normally also even when **SW52-1** is not used and the main power of the inverter is supplied at all times.
 - Using **SW52-1** requires connecting the input terminals [R0] and [T0] for an auxiliary control power. Without the connection, turning **SW52-1** OFF loses also the control power.
 - The sequence operates normally even if an alarm occurs in the inverter except when the inverter itself is broken. Therefore, for a critical facility, be sure to install an emergency switching circuit outside the inverter.
 - Turning ON both the magnetic contactor MC (88) at the commercial-power side and the MC (52-2) at the inverter output side at the same time supplies main power mistakenly from the output (secondary) side of the inverter, which may damage the inverter. To prevent it, be sure to set up an interlocking logic outside the inverter.

Examples of Sequence Circuits

1) Standard sequence

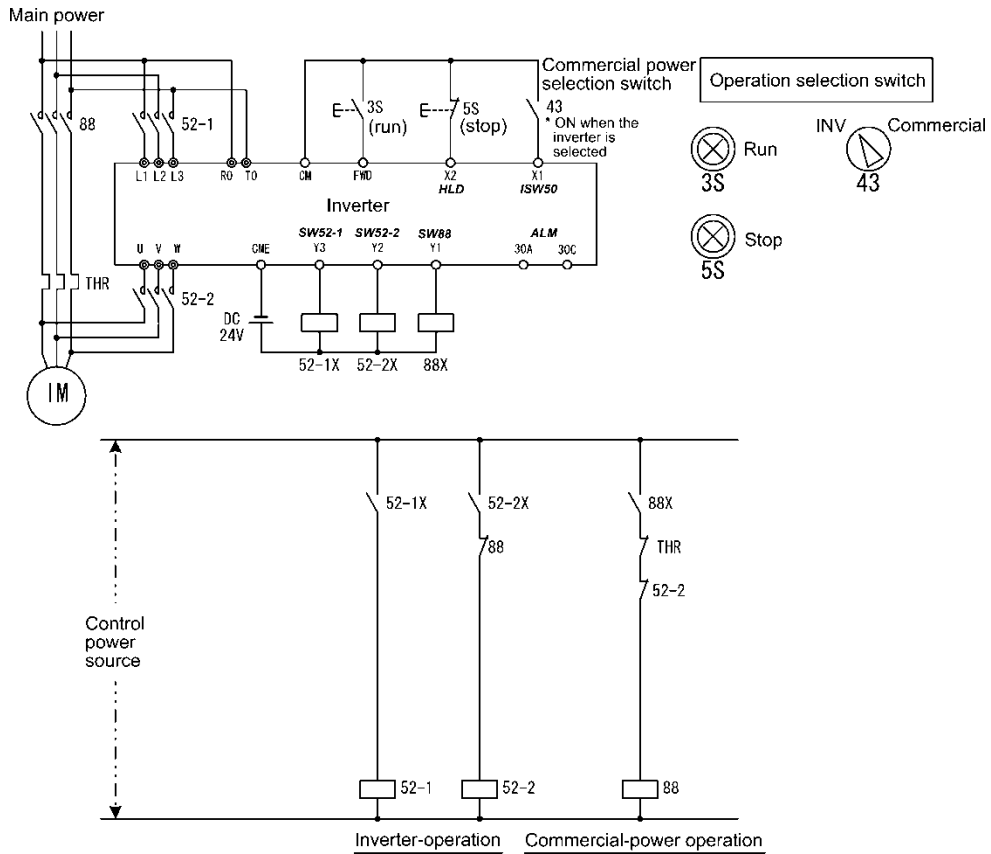

2) Sequence with an emergency switching function

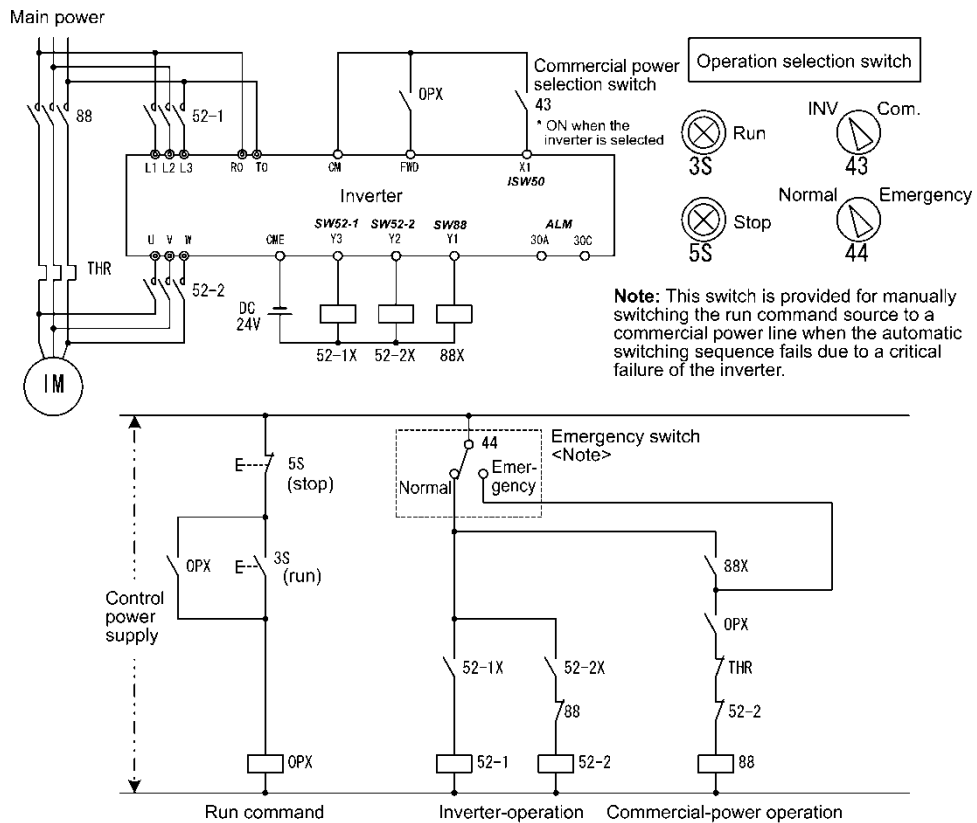

3) Sequence with an emergency switching function --Part 2 (Automatic switching by the alarm output issued by the inverter)

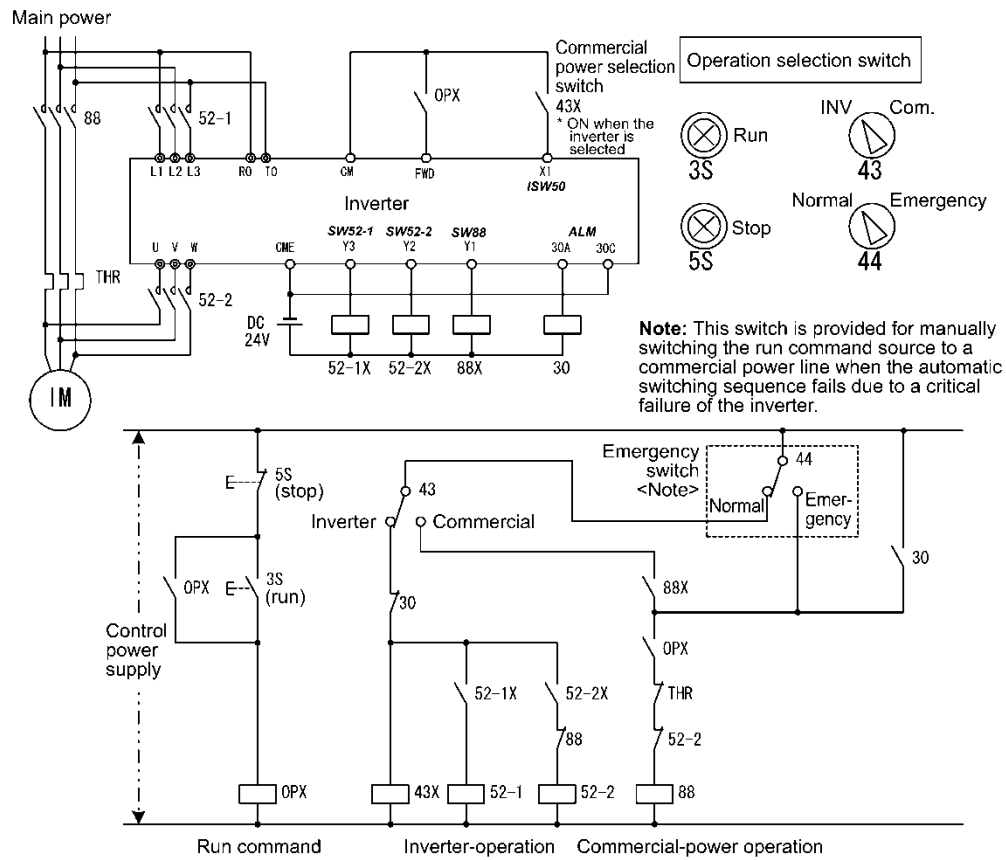

■ Servo-lock command -- LOCK (Function code data = 47)

Turning this terminal command ON enables a servo-lock command; turning it OFF disables a servo-lock command. Refer to J97 through J99.

■ Pulse train input -- PIN (Function code data = 48)

■ Pulse train sign -- SIGN (Function code data = 49)

Assigning the command **PIN** to digital input terminal [X7] enables the frequency command by the pulse train input. Assigning the command **SIGN** to one of the digital input terminals except [X7] enables the pulse train sign input to specify the polarity of frequency command. Refer to F01.

■ **Enable battery operation -- *BATRY* (Function code data = 59)**

Turning this terminal command ON cancels the undervoltage protection so that the inverter runs the motor with battery power under an undervoltage condition.

When ***BATRY*** is assigned to any digital input terminal, the inverter trips after recovery from power failure just as F14 = 1 regardless of F14 setting. When ***BATRY*** is ON, the main power down detection is disabled regardless of H72 setting.

Note Prerequisites for battery operation

- (1) The terminal command ***BATRY*** (data = 59) must be assigned to any digital input terminal.
- (2) A DC link bus voltage must be supplied from the battery to the main circuit (L1/R-L3/T or L2/S-L3/T) as shown in Figures A and B given below.
- (3) A regulated voltage (sine-wave or DC voltage) must be supplied to the auxiliary power supply (R0-T0).
- (4) For 200 V class series / 230V class series 37 kW / 60 HP and above and 400 V class series / 460V 75 kW / 125 HP and above, a regulated voltage (sine-wave) must be supplied to the auxiliary fan power supply (R1-T1) as shown in Figure B. The fan power supply connector must be configured for battery operation as shown in Figure C.
- (5) The ***BATRY***-assigned terminal (data = 59) must be turned ON at the same moment as closing of MC2.

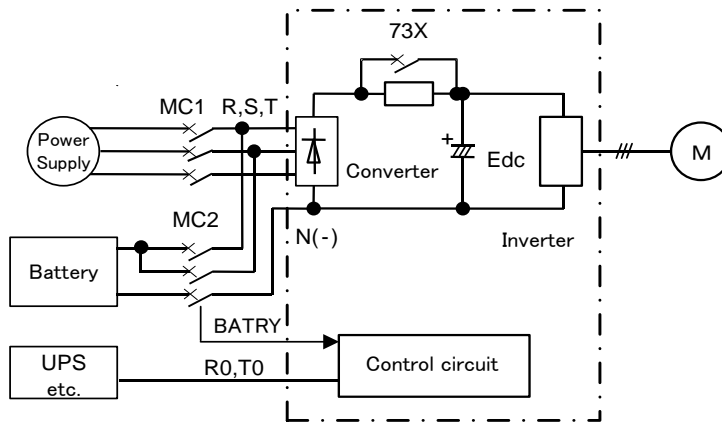

Figure A: Connection Diagram
 200 V Class: 30 kW (230V 50HP) and below
 400 V Class: 55 kW, (460V 100HP) and Below

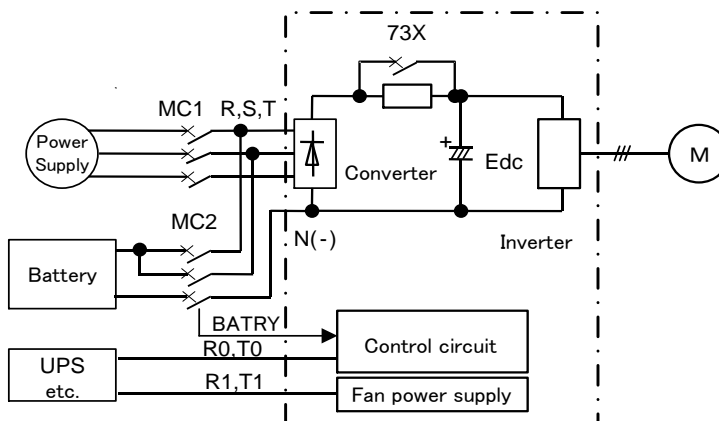

Figure B: Connection Diagram
 200 V Class: 37 kW (230V 60HP) and above
 400 V Class: 75 kW, (460V 125HP) and above

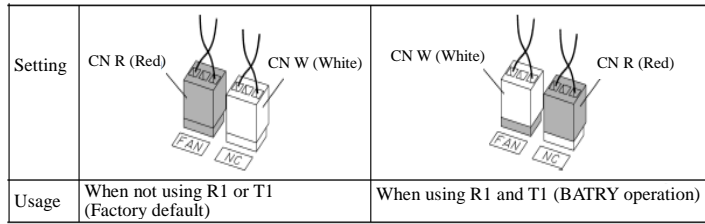
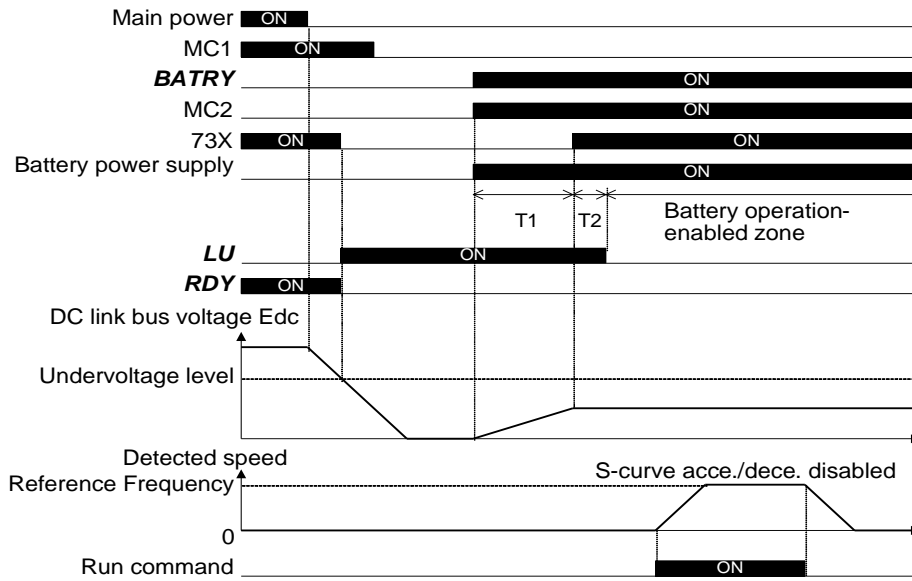

Figure C: Fan Power Supply Switching Connector

About battery operation (when BATTERY is ON)

- (1) The undervoltage protective function (*lu*) is deactivated.
- (2) The inverter can run the motor even under an undervoltage condition.
- (3) The **RDY** ("Inverter ready to run") output signal is forcibly turned OFF.
- (4) The bypass circuit of the charging resistor comes to be closed (73X ON) after a delay of time T1 from when the **BATTERY** is turned ON. Further, after a delay of time T2 (a maximum of 0.1 second), the battery operation starts. For the specifications of T1, see the table below.



Battery Operation Timing Diagram

T1 from **BATTERY** ON to 73X ON

Power condition	30 kW / 50 HP or below	37 kW / 60 HP or above
After the control power supply goes OFF, the battery power and control power are turned ON.	100 ms	500 ms
The control power remains ON or after a momentary power failure happens.	205 ms	

- (5) The S-curve acceleration/deceleration is disabled.
- (6) The battery operation speed can be calculated by the following formula.

$$\text{Reference speed (pre-ramp) during battery operation} \leq \frac{\text{Battery voltage} - 5[V]}{\sqrt{2} \times \text{Rated voltage}} \times \text{Rated speed} \times k$$

Where,

Battery voltage: 24 VDC or higher for 200 V class series / 230 V class series for USA
 48 VDC or higher for 400 V class series / 460 V class series for USA.

Rated speed : F04

Rated voltage : F05 (Motor rated voltage (V))

k: Safety coefficient (Less than 1, about 0.8)

Precautions

- (1) The battery power supply must be connected before or at the same moment as turning ON of **BATRY**.
- (2) As shown in the timing diagram above, battery operation is possible within the battery operation-enabled zone. There is a delay of "T1 + T2" after the **BATRY**, MC2, and battery power supply are turned ON.
- (3) The **BATRY** must not be turned ON when the voltage level is higher than the specified undervoltage level (that is, before the *Iu* appears after a power failure). Turning the **BATRY** ON causes the bypass circuit (73X) of the charging resistor to stick to ON (closed).
- (4) During battery operation, driving with a heavy load must be avoided and the motor must run with no load or braking load condition. Low battery voltage cannot generate sufficient torque, causing the motor to stall.
- (5) The battery operation must be performed at a low speed. Be careful with the battery capacity.
When a high voltage (e.g., 300 VDC for 200 V class series / 230 V class series for USA of inverters or 600 VDC for 400 V ones / 460 V ones for USA) is applied, not battery operation but normal operation must be performed.
- (6) In normal operation, the **BATRY** must be OFF. Turning the main power supply ON with the **BATRY** being ON could damage the rectifier diode because the 73X is ON.

■ **Count the run time of commercial power-drive motors 1 to 2 -- CRUN-M1, CRUN-M2 (Function code data = 72, 73)** These four terminal commands enable the inverter to count the cumulative run time of motors 1, 2 even when they are driven by commercial power (not by the inverter). When the **CRUN-M1, CRUN-M2** is ON, the inverter counts the run time that the motor 1, 2 is driven by commercial power.

■ **Select droop control – DROOP (Function code data = 76)**

This terminal command **DROOP** toggles droop control on and off. 📖 Refer to H28.

Droop	Droop control
ON	Enable
OFF	Disable

■ **Cancel PG alarm-- PG-CCL (Function code data = 77)**

When this terminal command is ON, the PG signal loss alarm is ignored. Use this terminal command when switching PG wires for switching motors, for example, to prevent it from being detected as PG wire break.

■ **Run forward -- FWD (Function code data = 98)**

Turning this terminal command ON runs the motor in the forward direction; turning it OFF decelerates it to stop.

 Tip This terminal command can be assigned to the same setting as E01 thru E07 only by parameter E98.

■ **Run reverse -- REV (Function code data = 99)**

Turning this terminal command ON runs the motor in the reverse direction; turning it OFF decelerates it to stop.

 Tip This terminal command can be assigned to the same setting as E01 thru E07 only by parameter E99.

E10 to E15 Acceleration Time 2 to 4, Deceleration Time 2 to 4

(Refer to F07.) see page 4-37

E16, E17 Torque Limiter 2-1, 2-2

(Refer to F40.) see page 4-58

E20 to E23 Terminal [Y1] to [Y4] Function
E24, E27 Terminal [Y5A/C] and [30A/B/C] Function (Relay output)

E20 through E24 and E27 assign output signals (listed on the next page) to general-purpose, programmable output terminals [Y1], [Y2], [Y3], [Y4], [Y5A/C] and [30A/B/C].

These function codes can also switch the logic system between normal and negative to define how the inverter interprets the ON or OFF state of each terminal. The factory default setting is normal logic system "Active ON."

Terminals [Y1], [Y2], [Y3] and [Y4] are transistor outputs and terminals [Y5A/C] and [30A/B/C] are relay contact outputs. In normal logic, if an alarm occurs, the relay will be energized so that [30A] and [30C] will be closed, and [30B] and [30C] opened. In negative logic, the relay will be de-energized so that [30A] and [30C] will be opened, and [30B] and [30C] closed. This may be useful for the implementation of failsafe power systems.

- 
Note • When a negative logic is employed, all output signals are active (e.g. an alarm would be recognized) while the inverter is powered OFF. To avoid causing system malfunctions by this, interlock these signals to keep them ON using an external power supply. Furthermore, the validity of these output signals is not guaranteed for approximately 1.5 seconds (for 40 HP or below) or 3 seconds (for 50 HP or above) after power-ON, so introduce such a mechanism that masks them during the transient period.

- 
Note • Terminals [Y5A/C] and [30A/B/C] use mechanical contacts that cannot stand frequent ON/OFF switching. Where frequent ON/OFF switching is anticipated (for example, limiting a current by using signals subjected to inverter output limit control such as switching to commercial power line or direct-on-line starting), use transistor outputs [Y1], [Y2], [Y3] and [Y4] instead.
 The service life of a relay is approximately 200,000 times if it is switched ON and OFF at one-second intervals.

The table below lists functions that can be assigned to terminals [Y1], [Y2], [Y3], [Y4], [Y5A/C], and [30A/B/C]. The descriptions are, in principle, arranged in the numerical order of assigned data. However, highly relevant signals are collectively described where one of them first appears. Refer to the function codes or signals in the "Related function codes/signals (data)" column, if any.

The EQ7 runs under "V/f control," "dynamic torque control," "vector control without speed sensor," or "vector control with speed sensor." Some output signals assigned apply exclusively to the specific drive control, which is indicated by letters Y (Applicable) and N (Not applicable) in the "Drive control" column of the table given below. (Refer to page 4-2.)

Explanations of each function are given in normal logic system "Active ON."

Function code data		Functions assigned	Symbol	Drive Control				Related function codes
Active ON	Active OFF			V/f	w/o PG	w/ PG	Torque control	
0	1000	Inverter running	RUN	Y	Y	Y	Y	—
1	1001	Frequency (speed) arrival signal	FAR	Y	Y	Y	N	<u>E30</u>
2	1002	Frequency (speed) detected	FDT	Y	Y	Y	Y	<u>E31, E32</u>
3	1003	Undervoltage detected (Inverter stopped)	LU	Y	Y	Y	Y	—
4	1004	Torque polarity detected	B/D	Y	Y	Y	Y	—
5	1005	Inverter output limiting	IOL	Y	Y	Y	Y	—
6	1006	Auto-restarting after momentary power failure	IPF	Y	Y	Y	Y	<u>F14</u>
7	1007	Motor overload early warning	OL	Y	Y	Y	Y	<u>E34, F10, F12</u>
8	1008	Keypad operation enabled	KP	Y	Y	Y	Y	—
10	1010	Inverter ready to run	RDY	Y	Y	Y	Y	—
11	—	Switch motor drive source between commercial power and inverter output (For MC on commercial line)	SW88	Y	N	N	N	<u>E01 to E07</u> ISW50 (40) ISW60 (41) J22
12	—	Switch motor drive source between commercial power and inverter output (For secondary side)	SW52-2	Y	N	N	N	
13	—	Switch motor drive source between commercial power and inverter output (For primary side)	SW52-1	Y	N	N	N	
15	1015	Select AX terminal function (For MC on primary side)	AX	Y	Y	Y	Y	—

Function code data		Functions assigned	Symbol	Drive Control				Related function codes
Active ON	Active OFF			V/f	w/o PG	w/ PG	Torque control	
22	1022	Inverter output limiting with delay	IOL2	Y	Y	Y	Y	IOL (5)
25	1025	Cooling fan in operation	FAN	Y	Y	Y	Y	<u>H06</u>
26	1026	Auto-resetting	TRY	Y	Y	Y	Y	<u>H04, H05</u>
27	1027	Universal DO	U-DO	Y	Y	Y	Y	—
28	1028	Heat sink overheat early warning	OH	Y	Y	Y	Y	—
29	1029	Synchronization completed	SY	N	N	Y	N	(See the PG Interface Card instruction manual.)
30	1030	Lifetime alarm	LIFE	Y	Y	Y	Y	(See Section 7.3. of UM)
31	1031	Frequency (speed) detected 2	FDT2	Y	Y	Y	Y	<u>E32, E36</u>
33	1033	Reference loss detected	REF OFF	Y	Y	Y	Y	<u>E65</u>
35	1035	Inverter output on	RUN2	Y	Y	Y	Y	RUN (0)
36	1036	Overload prevention control	OLP	Y	Y	Y	N	<u>H70</u>
37	1037	Current detected	ID	Y	Y	Y	Y	<u>E34, E35, E37, E38, E55, E56</u>
38	1038	Current detected 2	ID2	Y	Y	Y	Y	
39	1039	Current detected 3	ID3	Y	Y	Y	Y	
41	1041	Low current detected	IDL	Y	Y	Y	Y	
42	1042	PID alarm	PID-ALM	Y	Y	Y	N	<u>J11 to J13</u>
43	1043	Under PID control	PID-CTL	Y	Y	Y	N	<u>J01</u>
44	1044	Motor stopped due to slow flowrate under PID control	PID-STP	Y	Y	Y	N	<u>J08, J09</u>
45	1045	Low output torque detected	U-TL	Y	Y	Y	Y	<u>E78 to E81</u>
46	1046	Torque detected 1	TD1	Y	Y	Y	Y	
47	1047	Torque detected 2	TD2	Y	Y	Y	Y	
48	1048	Motor 1 selected	SWM1	Y	Y	Y	Y	<u>A42, b42, r42</u>
49	1049	Motor 2 selected	SWM2	Y	Y	Y	Y	
52	1052	Running forward	FRUN	Y	Y	Y	Y	—
53	1053	Running reverse	RRUN	Y	Y	Y	Y	—
54	1054	In remote operation	RMT	Y	Y	Y	Y	(See Section 4.2.2. UM)
56	1056	Motor overheat detected by thermistor	THM	Y	Y	Y	Y	<u>H26, H27</u>
57	1057	Brake signal	BRKS	Y	Y	Y	N	<u>J68 to J72</u>
58	1058	Frequency (speed) detected 3	FDT3	Y	Y	Y	Y	<u>E32, E54</u>
59	1059	Terminal [C1] wire break	C1OFF	Y	Y	Y	Y	—
70	1070	Speed valid	DNZS	N	Y	Y	Y	F25, F38
71	1071	Speed agreement	DSAG	N	Y	Y	N	d21, d22
72	1072	Frequency (speed) arrival signal 3	FAR3	Y	Y	Y	N	<u>E30</u>
76	1076	PG error detected	PG-ERR	N	Y	Y	N	d21 to d23
82	1082	Positioning completion signal	PSET	N	N	Y	N	<u>J97 to J99</u>
84	1084	Maintenance timer	MNT	Y	Y	Y	Y	H44, H78, H79
98	1098	Light alarm	L-ALM	Y	Y	Y	Y	<u>H81, H82</u>
99	1099	Alarm output (for any alarm)	ALM	Y	Y	Y	Y	—
101	1101	Enable circuit failure detected	DECF	Y	Y	Y	Y	—
102	1102	Enable input OFF	EN OFF	Y	Y	Y	Y	—
105	1105	Braking transistor broken	DBAL	Y	Y	Y	Y	H98

 Note Any negative logic (Active OFF) command cannot be assigned to the functions marked with "—" in the "Active OFF" column.

- Inverter running -- **RUN** (Function code data = 0)
Inverter output on -- **RUN2** (Function code data = 35)

These output signals tell the external equipment that the inverter is running at a starting frequency or higher. If assigned in negative logic (Active OFF), these signals can be used to tell the "Inverter being stopped" state.

Output signal	Basic function	Remarks
RUN	These signals come ON when the inverter is running.	Goes OFF even during DC braking or dew condensation prevention.
RUN2	Under V/f control: These signals come ON if the inverter output frequency exceeds the starting frequency, and go OFF if it drops below the stop frequency. The RUN signal can also be used as a "Speed valid" signal DNZS .	Comes ON even during DC braking, pre-exciting, zero speed control, or dew condensation prevention.

Under vector control, both **RUN** and **RUN2** come ON when zero speed control or servo-lock function is enabled.

- **Undervoltage detected (Inverter stopped) -- LU (Function code data = 3)**

This output signal comes ON when the DC link bus voltage of the inverter drops below the specified undervoltage level, and it goes OFF when the voltage exceeds the level.

This signal is ON also when the undervoltage protective function is activated so that the motor is in an abnormal stop state (e.g., tripped).

When this signal is ON, a run command is disabled if given.

- **Torque polarity detected -- B/D (Function code data = 4)**

The inverter issues the driving or braking polarity signal to this digital output judging from the internally calculated torque or torque command. This signal goes OFF when the detected torque is a driving one, and it goes ON when it is a braking one.

- **Inverter output limiting -- IOL (Function code data = 5)**
Inverter output limiting with delay -- IOL2 (Function code data = 22)

The output signal **IOL** comes ON when the inverter is limiting the output frequency by activating any of the following actions (minimum width of the output signal: 100 ms). The output signal **IOL2** comes ON when any of the following output limiting operation continues for 20 ms or more.

- Torque limiting (F40, F41, E16 and E17, Maximum internal value)
- Current limiting by software (F43 and F44)
- Instantaneous overcurrent limiting by hardware (H12 = 1)
- Automatic deceleration (Anti-regenerative control) (H69)

Note When the **IOL** signal is ON, it may mean that the output frequency may have deviated from the frequency specified by the frequency command because of this limiting function.

- **Keypad operation enabled -- KP (Function code data = 8)**

This output signal comes ON when the keypad is specified as a run command source.

- **Inverter ready to run -- RDY (Function code data = 10)**

This output signal comes ON when the inverter becomes ready to run by completing hardware preparation (such as initial charging of DC link bus capacitors and initialization of the control circuit) and no protective functions are activated.

- **Select AX terminal function -- AX (Function code data = 15)**

In response to a run command **FWD**, this output signal controls the magnetic contactor on the commercial-power supply side. It comes ON when the inverter receives a run command and it goes OFF after the motor decelerates to stop with a stop command received.

This signal immediately goes OFF upon receipt of a coast-to-stop command or when an alarm occurs.

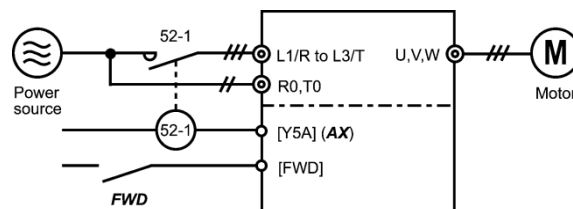

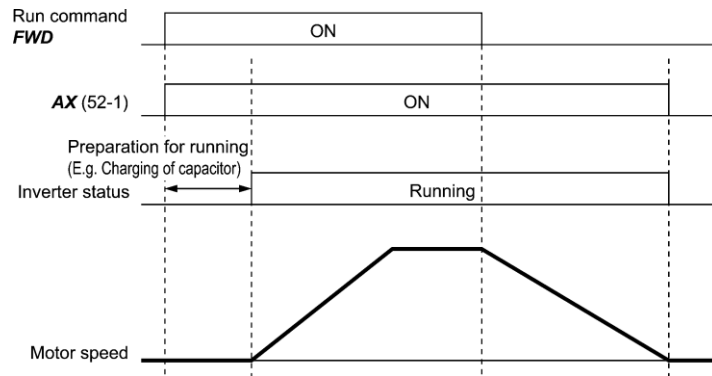

■ **Universal DO -- U-DO (Function code data = 27)**

Assigning this output signal to an inverter's output terminal and connecting the terminal to a digital input terminal of peripheral equipment via the RS-485 communications link or the fieldbus, allows the inverter to send commands to the peripheral equipment.

The universal DO can also be used as an output signal independent of the inverter operation.

For the procedure for access to Universal DO via the RS-485 communications link or fieldbus, refer to the respective instruction manual.

■ **Heat sink overheat early warning -- OH (Function code data = 28)**

This output signal is used to issue a heat sink overheat early warning that allows for corrective action before an overheat trip *Oh1* actually happens.

This signal comes ON when the temperature of the heat sink exceeds the "overheat trip temperature minus 5°C (41°F)," and it goes OFF when it drops down to the "overheat trip temperature minus 8°C (46°F)."

This signal comes ON also when the internal air circulation DC fan (75 HP or above for 230 V series or 125 HP or above for 460 V series) has locked.

■ **Synchronization completed -- SY (Function code data = 29)**

This output signal comes ON when the control target comes inside the synchronization completion detection angle in synchronous running.

For details about synchronous operation, refer to the PG Interface Card instruction manual.

■ **Lifetime alarm -- LIFE (Function code data = 30)**

This output signal comes ON when it is judged that the service life of any one of capacitors (DC link bus capacitors and electrolytic capacitors on the printed circuit boards) and cooling fan has expired.

This signal should be used as a guide for replacement of the capacitors and cooling fan. If this signal comes ON, use the specified maintenance procedure to check the service life of these parts and determine whether the parts should be replaced or not. (Refer to Chapter 7 of the user manual, Section 7.3 "List of Periodic Replacement Parts.")

This signal comes ON also when the internal air circulation DC fan (75 HP or above for 230 V series or 125 HP or above for 460 V series) has locked.

■ **Under PID control -- PID-CTL (Function code data = 43)**

This output signal comes ON when PID control is enabled ("Cancel PID control" (*Hz/PID*) = OFF) and a run command is ON. (Refer to the description of J01.)

Note When PID control is enabled, the inverter may stop due to the slow flowrate stopping function or other reasons, with the **PID-CTL** signal being ON. As long as the **PID-CTL** signal is ON, PID control is effective, so the inverter may abruptly resume its operation, depending on the feedback value in PID control.

WARNING

When PID control is enabled, even if the inverter stops its output during operation because of sensor signals or other reasons, operation will resume automatically. Design machinery so that safety is ensured in consideration of these events.

Otherwise, accidents could occur.

- Running forward -- **FRUN** (Function code data = 52)
- Running reverse -- **RRUN** (Function code data = 53)

Output signal	Assigned data	Running forward	Running reverse	Inverter stopped
FRUN	52	ON	OFF	OFF
RRUN	53	OFF	ON	OFF

■ **In remote operation -- RMT (Function code data = 54)**

This output signal comes ON when the inverter switches from local to remote mode.

📖 For details of switching between remote and local modes, refer to user Manual Chapter 4, Section 4.2.2 "Remote and local modes."

■ **Terminal [C1] wire break -- C1OFF (Function code data = 59)**

This output signal comes ON when the inverter detects that the input current to terminal [C1] drops below 2 mA interpreting it as the terminal [C1] wire broken.

■ **Speed valid -- DNZS (Function code data = 70)**

This output signal comes ON when the reference or detected speed exceeds the stop frequency specified by function code F25. It goes OFF when the speed is below the stop frequency for 100 ms or longer.

Under vector control with speed sensor, F38 switches the decision criterion between the reference and detected speed. Under vector control without speed sensor, the reference speed is used as a decision criterion. (📖 Refer to the descriptions of F25 and F38.)

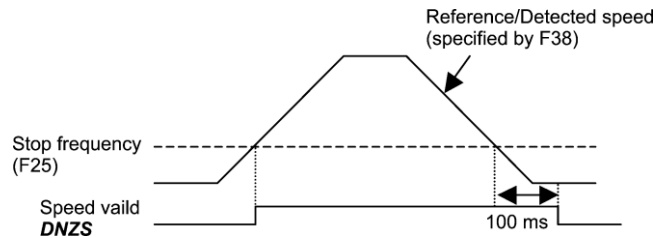

■ **Alarm output (for any alarm) -- ALM (Function code data = 99)**

This output signal comes ON if any of the protective functions is activated and the inverter enters Alarm mode.

■ **Enable circuit failure detected -- DECF (Function code data = 101)**

This output signal comes ON when the inverter detects a failure of the Enable circuit(*1).

Configure a feedback circuit of the Enable input function as needed to feed back the transistor output of the **DECF**-assigned inverter to the reset input of the upper safety relay unit for turning the Enable command off and shutdown of the inverter output.

■ **Enable input OFF -- EN OFF (Function code data = 102)**

This output signal comes ON when Enable inputs on [EN1] and [EN2] terminals are OFF (opened). See the table below.

*1: These signals do not assure detection of all of single failures. (Compliant with EN ISO13849-1 PL=d Cat. 3)

Logic Table for **DECF** and **EN OFF** Signals

Main power input L1/R, L2/S, L3/T	Enable input		Transistor output or Alarm relay output (for any error) *2		Output
	EN1-PLC	EN2-PLC	DECF	EN OFF	
OFF	x	x	OFF	OFF	Shut down (Safe Torque Off (STO) *3)
ON	OFF	OFF	OFF	ON	Shut down (Safe Torque Off (STO) *3)
	ON	ON	OFF	OFF	Wait for a run command
	ON	OFF	ON *4	OFF	Shut down (Safe Torque Off (STO) *3)
	OFF	ON	ON *4	OFF	Shut down (Safe Torque Off (STO) *3)

x: Independent of this state, the output is determined.

*2 To use these functions, it is necessary to assign **DECF/EN OFF** to digital output terminals (function codes E20 to E24 and E27, data = 101/102 or 1101/1102 (negative logic)).

*3 Output shutdown (Safe Torque Off) prescribed in IEC61800-5-2.

*4 If either one of these terminals are kept OFF for 50ms or more, the inverter interprets it as a discrepancy, causing an alarm *ecf*. This alarm state can be cleared only by turning the inverter power off and on clears this alarm.

■ **Braking transistor broken -- DBAL (Function code data = 105)**

If the inverter detects a breakdown of the braking transistor, it issues the braking transistor alarm (*dbbR*) and also the output signal **DBAL**. Detection of braking transistor broken can be cancelled by H98. (40 HP or below) (Refer to the description of H98.)

Note Breakdown of the braking transistor could lead to the secondary breakdown of the braking resistor and inverter's internal units. Use this output signal **DBAL** to detect abnormal operation of the built-in braking transistor and to cut off power to the magnetic contactor in inverter primary circuits, for preventing spread of the damage.

E30 Frequency Arrival (Hysteresis width)

E30 specifies the detection level (hysteresis width) for the "Frequency (speed) arrival signal" **FAR** and the "Frequency (speed) arrival signal 3" **FAR3**.

Output signal	Data assigned to output terminal	Operating condition 1	Operating condition 2
Frequency (speed) arrival signal FAR	1	Both signals come ON when the difference between the output frequency (estimated/detected speed) and the reference frequency (reference speed) comes within the frequency arrival hysteresis width specified by E30.	FAR always goes OFF when the run command is OFF or the reference speed is "0."
Frequency (speed) arrival signal 3 FAR3	72		When the run command is OFF, the inverter regards the reference speed as "0," so FAR3 comes ON as long as the output frequency (estimated/detected speed) is within the range of "0 ± the frequency arrival hysteresis width specified by E30."

- Data setting range: 0.0 to 10.0 (Hz)

The operation timings of each signal are shown below.

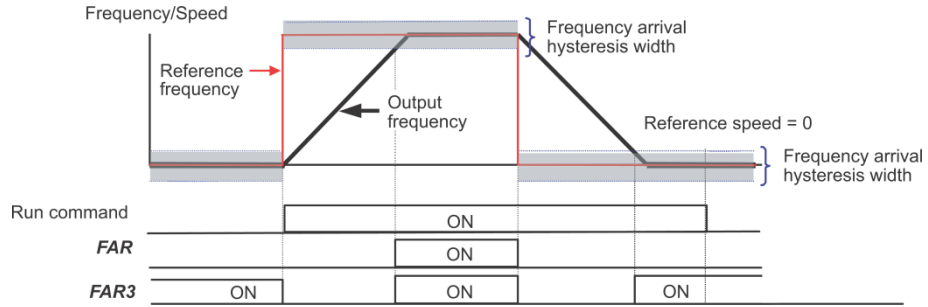

E31, E32 Frequency Detection (Level and Hysteresis width) E36, E54 (Frequency Detection 2 and 3 (Level))

When the output frequency (estimated/detected speed) exceeds the frequency detection level specified by E31, the "Frequency (speed) detected signal" comes ON; when it drops below the "Frequency detection level minus Hysteresis width specified by E32," it goes OFF.

The following three settings are available.

Output signal	Data assigned to output terminal	Operation level	Hysteresis width
		Range: 0.0 to 500.0 Hz	Range: 0.0 to 500.0 Hz
Frequency (speed) detected signal FDT	2	E31	E32
Frequency (speed) detected signal 2 FDT2	31	E36	
Frequency (speed) detected signal 3 FDT3	58	E54	

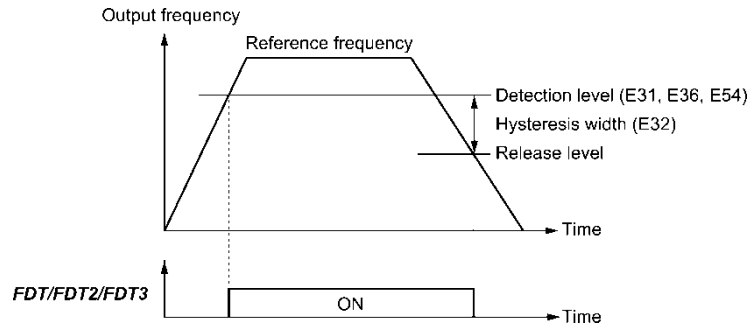

E34, E35 Overload Early Warning/Current Detection (Level and Timer)

E37, F38 (Current Detection 2/Low Current Detection (Level and Timer))
 E55, E56 (Current Detection 3 (Level and Timer))

These function codes define the detection level and time for the "Motor overload early warning" **OL**, "Current detected" **ID**, "Current detected 2" **ID2**, "Current detected 3" **ID3**, and "Low current detected" **IDL** output signals.

Output signal	Data assigned to output terminal	Operation level	Timer	Motor characteristics	Thermal time constant
		Range	Range: 0.01 to 600.00 s	Range	Range: 0.5 to 75.0 min
OL	7	E34	-	F10	F12
ID	37	E34	E35	-	-
ID2	38	E37	E38		
ID3	39	E55	E56		
IDL	41	E37	E38		

- Data setting range

Operation level: 0.00 (Disable), 1 to 200% of inverter rated current

Motor characteristics 1: Enable (For a general-purpose motor with shaft-driven cooling fan)
 2: Enable (For an inverter-driven motor, non-ventilated motor, or motor with separately powered cooling fan)

■ Motor overload early warning signal -- **OL**

The **OL** signal is used to detect a symptom of an overload condition (alarm code *0/1*) of the motor so that the user can take an appropriate action before the alarm actually happens.

The **OL** signal turns ON when the inverter output current exceeds the level specified by E34. In typical cases, set E34 data to 80 to 90% against F11 data (Electronic thermal overload protection for motor 1, Overload detection level). Specify also the thermal characteristics of the motor with F10 (Select motor characteristics) and F12 (Thermal time constant).

■ Current detected, Current detected 2 and Current detected 3 -- **ID**, **ID2** and **ID3**

When the inverter output current exceeds the level specified by E34, E37 or E55 for the period specified by E35, E38 or E56, the **ID**, **ID2** or **ID3** signal turns ON, respectively. When the output current drops below 90% of the rated operation level, the **ID**, **ID2** or **ID3** turns OFF. (The minimum ON-duration is 100 ms.)

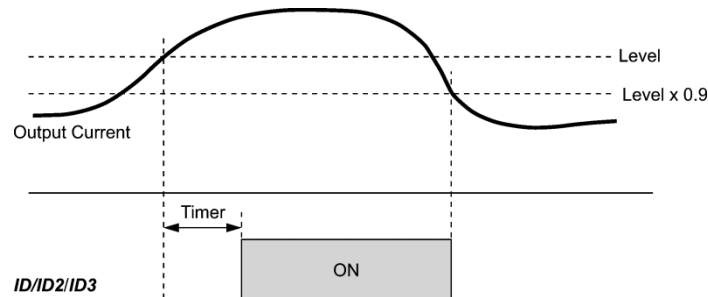

■ Low current detected -- **IDL**

This signal turns ON when the output current drops below the level specified by E37 (Low current detection, Level) for the period specified by E38 (Timer). When the output current exceeds the "Low current detection level plus 5% of the inverter rated current," it goes OFF. (The minimum ON-duration is 100 ms.)

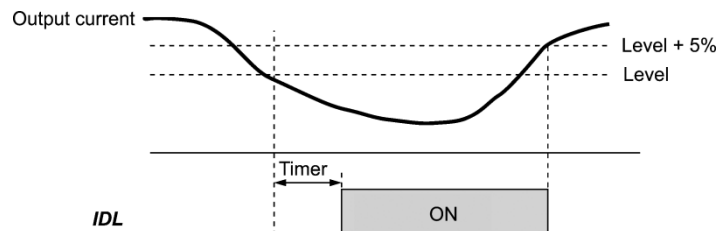

These function codes specify PID display coefficients A and B to convert a PID command (process command or dancer position command) and its feedback into mnemonic physical quantities to display.

- Data setting range: -999 to 0.00 to 9990 for PID display coefficients A and B

■ Display coefficients for PID process command and its feedback (J01 = 1 or 2)

E40 specifies coefficient A that determines the display value at 100% of the PID process command or its feedback, and E41 specifies coefficient B that determines the display value at 0%.

The display value is determined as follows:

Display value = (PID process command or its feedback (%))/100 × (Display coefficient A - B) + B

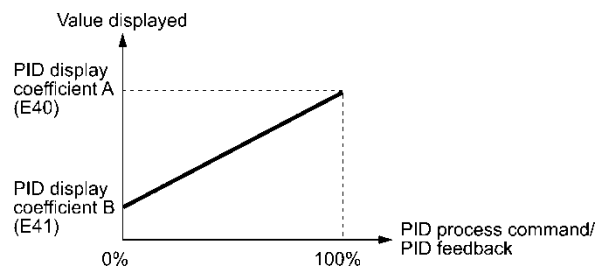

Example

Maintaining the pressure around 16 kPa (sensor voltage 3.13 V) while the pressure sensor can detect 0 to 30 kPa over the output voltage range of 1 to 5 V:

Select terminal [12] as a feedback terminal and set the gain to 200% so that 5 V corresponds to 100%.

The following E40 and E41 settings allow you to monitor or specify the values of the PID process command and its feedback on the keypad as pressure.

PID display coefficient A (E40) = 30.0, that determines the display value at 100% of PID process command or its feedback

PID display coefficient B (E41) = -7.5, that determines the display value at 0% of PID process command or its feedback

To control the pressure at 16 kPa on the keypad, set the value to 16.0.

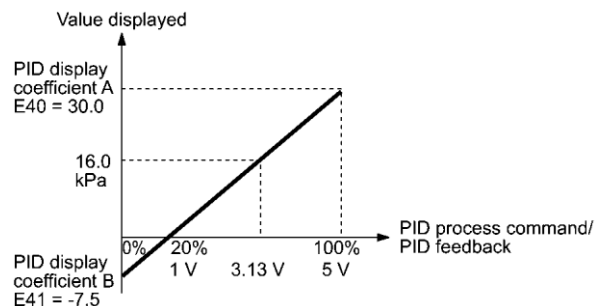

■ **Display coefficients for PID dancer position command and its feedback (J01 = 3)**

Under PID dancer control, the PID command and its feedback operate within the range $\pm 100\%$, so specify the value at $+100\%$ of the PID dancer position command or its feedback as coefficient A with E40, and the value at -100% as coefficient B with E41.

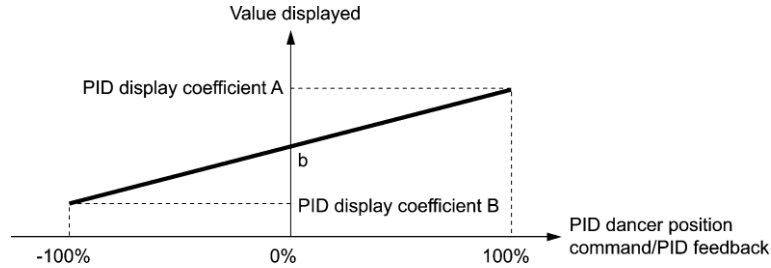

If the sensor output is unipolar, the PID dancer control operates within the range from 0 to $+100\%$, so virtually specify the value at -100% as coefficient B.

That is, suppose "b" = "Display value at 0%," then:

$$\text{Display coefficient B} = 2b - A$$

📖 For details about the PID control, refer to the description of J01 and later.

📖 For the display method of the PID command and its feedback, refer to the description of E43.

■ **Display coefficient for analog input monitor**

By inputting analog signals from various sensors such as temperature sensors in air conditioners to the inverter, you can monitor the state of peripheral devices via the communications link. By using an appropriate display coefficient, you can also have various values converted into physical values such as temperature and pressure before they are displayed.

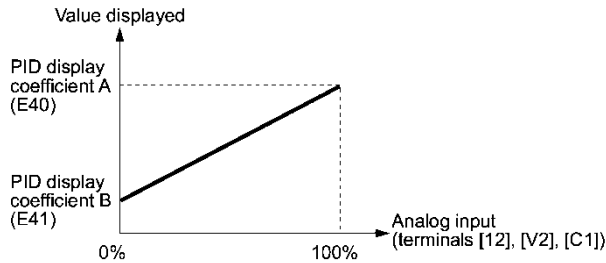

📖 To set up the analog input monitor, use function codes E61 through E63. Use E43 to choose the item to be displayed.

E42 LED Display Filter

E42 specifies a filter time constant to be applied for displaying the monitored running status except the speed monitor (E43 = 0) on the LED monitor on the keypad. If the display fluctuates and is hard to read due to load fluctuation or other causes, increase this filter time constant.

- Data setting range: 0.0 to 5.0 (s)

E43 specifies the running status item to be monitored and displayed on the LED monitor.

Specifying the speed monitor with E43 provides a choice of speed-monitoring formats selectable with E48 (LED Monitor).

Monitor item	Display sample on the LED monitor	Unit	Meaning of displayed value	Function code data for E43
Speed monitor	Function code E48 specifies what to be displayed on the LED monitor.			0
Output frequency 1 (before slip compensation)	5000	Hz	Frequency actually being output	(E48 = 0)
Output frequency 2 (after slip compensation)	5000	Hz	Frequency actually being output	(E48 = 1)
Reference frequency	5000	Hz	Reference frequency being specified	(E48 = 2)
Motor speed	1500	r/min	Output frequency (Hz) $\times \frac{120}{P01}$	(E48 = 3)
Load shaft speed	3000	r/min	Output frequency (Hz) \times E50	(E48 = 4)
Line speed	3000	m/min	Output frequency (Hz) \times E50	(E48 = 5)
Display speed (%)	500	%	$\frac{\text{Output frequency}}{\text{Maximum frequency}} \times 100$	(E48 = 7)
Output current	1234	A	Current output from the inverter in RMS	3
Output voltage	200	V	Voltage output from the inverter in RMS	4
Calculated torque	50	%	Motor output torque in % (Calculated value)	8
Input power	1025	kW	Input power to the inverter	9
PID command	1000	—	PID command/feedback amount transformed to that of virtual physical value of the object to be controlled (e.g. temperature) Refer to function codes E40 and E41 for details.	10
PID feedback amount	1000	—		12
PID output	1000	%	PID output in % as the maximum frequency being at 100%	14
Load factor	50	%	Load factor of the motor in % as the rated output being at 100%	15
Motor output	985	kW	Motor output in kW	16
Analog input	8200	—	An analog input to the inverter in a format suitable for a desired scale. Refer to function codes E40 and E41 for details.	17
Torque current	48	%	Torque current command value or calculated torque current	23
Magnetic flux command	50	%	Magnetic flux command value (Available only under vector control)	24
Input watt-hour	1000	kWh	$\frac{\text{Input watt-hour (kWh)}}{100}$	25

E44 LED Monitor (Display when stopped)

E44 specifies whether the specified value (data = 0) or the output value (data = 1) to be displayed on the LED monitor of the keypad when the inverter is stopped. The monitored item depends on the E48 (LED monitor, Speed monitor item) setting as shown below.

Data for E48	Monitored item	What to be displayed when the inverter stopped	
		E44 = 0 (Specified value)	E44 = 1 (Output value)
0	Output frequency 1 (before slip compensation)	Reference frequency	Output frequency 1 (before slip compensation)
1	Output frequency 2 (after slip compensation)	Reference frequency	Output frequency 2 (after slip compensation)
2	Reference frequency	Reference frequency	Reference frequency
3	Motor speed	Reference motor speed	Motor speed
4	Load shaft speed	Reference load shaft speed	Load shaft speed
5	Line speed	Reference line speed	Line speed
7	Display speed (%)	Reference display speed	Display Speed

E45 LCD Monitor (Item selection)

E45 specifies the LCD monitor display mode to be applied when the inverter is in Running mode.

Data for E45	Function
0	Running status, rotational direction and operation guide
1	Bar charts for output frequency, current and calculated torque

Example of display for E45 = 0 (during running)

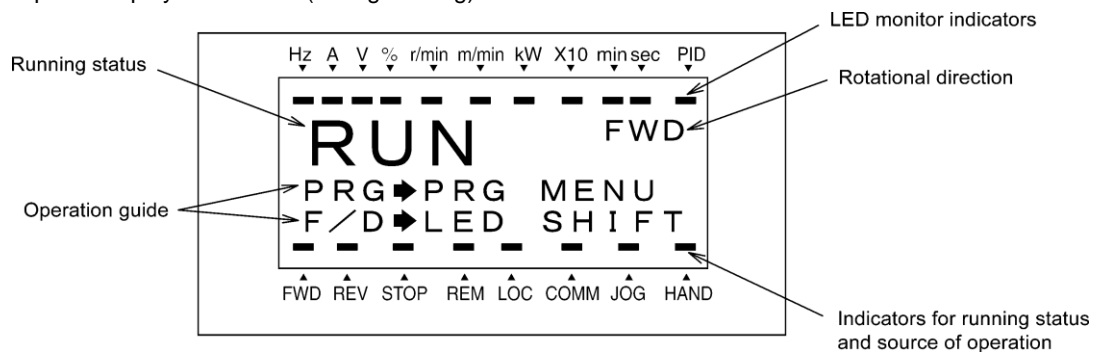

Example of display for E45 = 1 (during running)

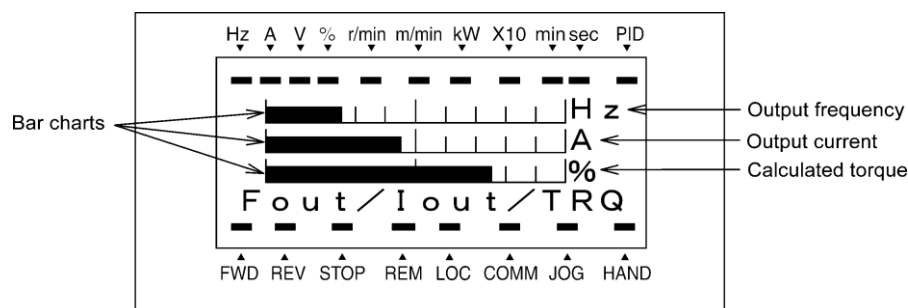

Full-scale values on bar charts

Item displayed	Full scale
Output frequency	Maximum frequency
Output current	Inverter rated current × 200%
Calculated torque	Motor rated torque × 200%

E46 LCD Monitor (Language selection)

E46 specifies the language to display on the keypad (TP-G1W-J1) as follows:

Data for E46	Language
0	Japanese
1	English
2	German
3	French
4	Spanish
5	Italian

E47 LCD Monitor (Contrast control)

E47 adjusts the contrast of the LCD monitor on the keypad as follows:

Data for E47	0, 1, 2, 3, 4, 5, 6, 7, 8, 9, 10
Contrast	Low ←————→ High

E48 LED Monitor (Speed monitor item)

(Refer to E43.) see page 4-98

E50 Coefficient for Speed Indication

E50 specifies the coefficient that is used when the load shaft speed or line speed is displayed on the LED monitor. (Refer to the description of E43.)

$$\text{Load shaft speed (r/min)} = (\text{E50: Coefficient for speed indication}) \times (\text{Output frequency Hz})$$

$$\text{Line speed (m/min)} = (\text{E50: Coefficient for speed indication}) \times (\text{Output frequency Hz})$$

- Data setting range: 0.01 to 200.00

E51 Display Coefficient for Input Watt-hour Data

E51 specifies a display coefficient (multiplication factor) for displaying the input watt-hour data (5_10) in a part of maintenance information on the keypad.

$$\text{Input watt-hour data} = \text{Display coefficient (E51 data)} \times \text{Input watt-hour (kWh)}$$

- Data setting range: 0.000 (cancel/reset); 0.001 to 9999

 **Note** Setting E51 data to 0.000 clears the input watt-hour and its data to "0." After clearing, be sure to restore E51 data to the previous value; otherwise, input watt-hour data will not be accumulated.

E54	Frequency Detection 3 (Level)	(Refer to E31.) see page 4-94
------------	--------------------------------------	-------------------------------

E55, E56	Current Detection 3 (Level, Timer)	(Refer to E34.) see page 4-95
-----------------	---	-------------------------------

E61 to E63 Terminal [12] Extended Function
Terminal [C1] Extended Function
Terminal [V2] Extended Function

As listed below, under torque control, analog inputs through terminals [12], [C1], and [V2] specify the motor speed limit values. To limit the motor speed to the maximum frequency (F02, A01), apply a full-scale analog input (maximum input).

It is recommended that this speed limit function be used together with d35 (Overspeed detection level).

Data for E61, E62, or E63	Input assigned to [12], [C1] and [V2]:	Description
0	None	—
1	Auxiliary frequency command 1	Auxiliary frequency input to be added to the reference frequency given by frequency command 1 (F01). This is not added to any other reference frequencies given by frequency command 2 and multi-frequency commands, etc.
2	Auxiliary frequency command 2	Auxiliary frequency input to be added to all reference frequencies given by frequency command 1, frequency command 2, multi-frequency commands, etc.
3	PID command 1	Command sources such as temperature and pressure under PID control. It is also necessary to configure function code J02.
5	PID feedback amount	Feedback amounts such as temperature and pressure under PID control.
6	Ratio setting	This is used to multiply the final frequency command value by this value, for use in the constant line speed control by calculating the winder diameter or in ratio operation with multiple inverters.
7	Analog torque limit value A	This is used when analog inputs are used as torque limiters. (☞ Refer to F40 (Torque Limiter 1-1).)
8	Analog torque limit value B	This is used when analog inputs are used as torque limiters. (☞ Refer to F40 (Torque Limiter 1-1).)
10	Torque command	Analog inputs to be used as torque commands under torque control. (☞ Refer to H18 (Torque Control).)
11	Torque current command	Analog inputs to be used as torque current commands under torque control. (☞ Refer to H18 (Torque Control).)
17	Speed Limit FWD	Speed Limit in Forward Direction
18	Speed Limit REV	Speed Limit in Reverse Direction
20	Analog signal input monitor	By inputting analog signals from various sensors such as the temperature sensors in air conditioners to the inverter, you can monitor the state of external devices via the communications link. By using an appropriate display coefficient, you can also have various values to be converted into physical values such as temperature and pressure before they are displayed.

 **Note** If these terminals have been set up to have the same data, the operation priority is given in the following order: E61 > E62 > E63
 Function codes C31 to C45 (Analog input adjustment) apply to these analog inputs.

E64 Saving of Digital Reference Frequency

E64 specifies how to save the reference frequency specified in digital formats by the \odot / \ominus keys on the keypad as shown below.

Data for E64	Function
0	Automatic saving when the main power is turned OFF The reference frequency will be automatically saved when the main power is turned OFF. At the next power-on, the reference frequency at the time of the previous power-off applies.
1	Saving by pressing \odot key Pressing the \odot key saves the reference frequency. If the control power is turned OFF without pressing the \odot key, the data will be lost. At the next power-ON, the inverter uses the reference frequency saved when the \odot key was pressed last.

E65 Reference Loss Detection (Continuous running frequency)

When the analog frequency command (setting through terminal [12], [C1], or [V2]) has dropped below 10% of the reference frequency within 400 ms, the inverter presumes that the analog frequency command wire has been broken and continues its operation at the frequency determined by the ratio specified by E65 to the reference frequency. Refer to E20 through E24 and E27 (data = 33).

When the frequency command level (in voltage or current) returns to a level higher than that specified by E65, the inverter presumes that the broken wire has been fixed and continues to run following the frequency command.

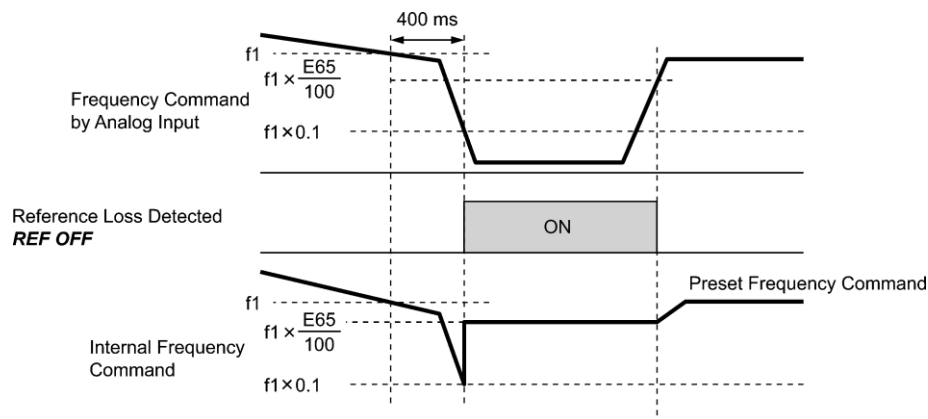

In the diagram above, f_1 is the level of the analog frequency command sampled at any given time. The sampling is repeated at regular intervals to continually monitor the wiring connection of the analog frequency command.

- Data setting range: 0 (Decelerate to stop), 20 to 120%, 999 (Disable)

Note Avoid an abrupt voltage or current change for the analog frequency command. An abrupt change may be interpreted as a wire break.

Setting E65 data at "999" (Disable) allows the **REF OFF** signal ("Reference loss detected") to be issued, but does not allow the reference frequency to change (the inverter runs at the analog frequency command as specified).

When E65 = "0" or "999," the reference frequency level at which the broken wire is recognized as fixed is " $f_1 \times 0.2$."

When E65 = "100" (%) or higher, the reference frequency level at which the wire is recognized as fixed is " $f_1 \times 1$."

The reference loss detection is not affected by the setting of analog input adjustment (filter time constants: C33, C38, and C43)

E78, E79 Torque Detection 1 (Level and Timer)
E80, E81 Torque Detection 2/Low Torque Detection (Level and Timer)

E78 specifies the operation level and E79 specifies the timer, for the output signal **TD1**. E80 specifies the operation level and E81 specifies the timer, for the output signal **TD2** or **U-TL**.

Output signal	Assigned data	Operation level	Timer
		Range: 0 to 300%	Range: 0.01 to 600.00 s
TD1	46	E78	E79
TD2	47	E80	E81
U-TL	45	E80	E81

■ **Torque detected 1 -- TD1, Torque detected 2 -- TD2**

The output signal **TD1** or **TD2** comes ON when the torque value calculated by the inverter or torque command exceeds the level specified by E78 or E80 (Torque detection (Level)) for the period specified by E79 or E81 (Torque detection (Timer)), respectively. The signal turns OFF when the calculated torque drops below "the level specified by E78 or E80 minus 5% of the motor rated torque." The minimum ON-duration is 100 ms.

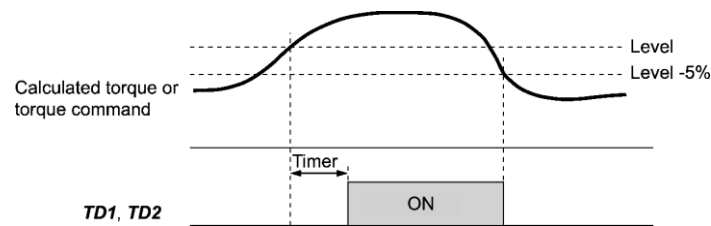

■ **Low output torque detected--U-TL**

This output signal comes ON when the torque value calculated by the inverter or torque command drops below the level specified by E80 (Low torque detection (Level)) for the period specified by E81 (Low torque detection (Timer)). The signal turns OFF when the calculated torque exceeds the "level specified by E80 plus 5% of the motor rated torque." The minimum ON-duration is 100 ms.

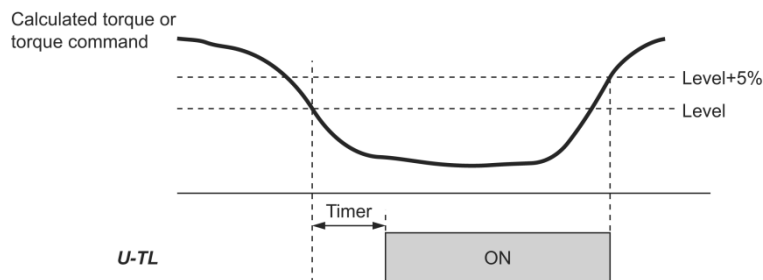

In the inverter's low frequency operation, as a substantial error in torque calculation occurs, no low torque can be detected within the operation range at less than 20% of the base frequency (F04). (In this case, the result of recognition before entering this operation range is retained.)

The **U-TL** signal goes off when the inverter is stopped.

Since the motor parameters are used in the calculation of torque, it is recommended that auto-tuning be applied by function code P04 to achieve higher accuracy.

E98, E99 Terminal [FWD] Function
Terminal [REV] Function

(Refer to E01 to E07.)

4.2.3 C codes (Control functions)

C01 to C03 Jump Frequency 1, 2 and 3 C04 Jump Frequency (Hysteresis width)

These function codes enable the inverter to jump over three different points on the output frequency in order to skip resonance caused by the motor speed and natural frequency of the driven machinery (load).

- While increasing the reference frequency, the moment the reference frequency reaches the bottom of the jump frequency band, the inverter keeps the output at that bottom frequency. When the reference frequency exceeds the upper limit of the jump frequency band, the internal reference frequency takes on the value of the reference frequency. When decreasing the reference frequency, the situation will be reversed.
- When more than two jump frequency bands overlap, the inverter actually takes the lowest frequency within the overlapped bands as the bottom frequency and the highest as the upper limit. Refer to the figure on the lower right.

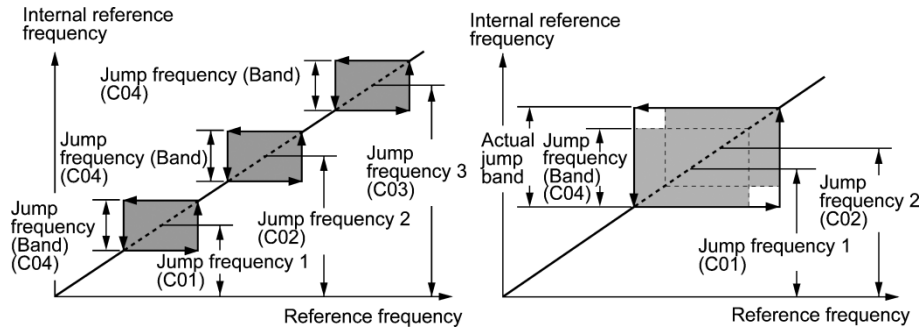

■ **Jump frequencies 1, 2 and 3 (C01, C02 and C03)** Data setting range: 0.0 to 500.0 (Hz)
Specify the center of the jump frequency band. (Setting to 0.0 results in no jump frequency band.)

■ **Jump frequency hysteresis width (C04)** Data setting range: 0.0 to 30.0 (Hz)
Specify the jump frequency hysteresis width. (Setting to 0.0 results in no jump frequency band.)

C05 to C19 Multi-frequency 1 to 15

- These function codes specify 15 frequencies required for driving the motor at frequencies 1 to 15. Turning terminal commands **SS1**, **SS2**, **SS4** and **SS8** ON/OFF selectively switches the reference frequency of the inverter in 15 steps. To use these features, assign **SS1**, **SS2**, **SS4** and **SS8** ("Select multi-frequency") to the digital input terminals with C05 to C19 (data = 0, 1, 2, and 3).

■ **Multi-frequency 1 to 15 (C05 through C19)** Data setting range: 0.00 to 500.00 (Hz)

The combination of **SS1**, **SS2**, **SS4** and **SS8** and the selected frequencies are as follows.

SS8	SS4	SS2	SS1	Selected frequency command
OFF	OFF	OFF	OFF	Other than multi-frequency *
OFF	OFF	OFF	ON	C05 (multi-frequency 1)
OFF	OFF	ON	OFF	C06 (multi-frequency 2)
OFF	OFF	ON	ON	C07 (multi-frequency 3)
OFF	ON	OFF	OFF	C08 (multi-frequency 4)
OFF	ON	OFF	ON	C09 (multi-frequency 5)
OFF	ON	ON	OFF	C10 (multi-frequency 6)
OFF	ON	ON	ON	C11 (multi-frequency 7)
ON	OFF	OFF	OFF	C12 (multi-frequency 8)
ON	OFF	OFF	ON	C13 (multi-frequency 9)
ON	OFF	ON	OFF	C14 (multi-frequency 10)
ON	OFF	ON	ON	C15 (multi-frequency 11)
ON	ON	OFF	OFF	C16 (multi-frequency 12)
ON	ON	OFF	ON	C17 (multi-frequency 13)
ON	ON	ON	OFF	C18 (multi-frequency 14)
ON	ON	ON	ON	C19 (multi-frequency 15)

* "Other than multi-frequency" includes frequency command 1 (F01), frequency command 2 (C30) and other command sources except multi-frequency commands.

Note: SS1, SS2, SS4 and SS8 are assigned to input terminals by parameters E01 through E07.

■ **When enabling PID control (J01 = 1, 2, or 3)**

Under the PID control, a multi-frequency command can be specified as a preset value (3 different frequencies). It can also be used for a manual speed command even with the PID control being canceled (**Hz/PID** = ON) or for a primary reference frequency under the PID dancer control.

- PID command

SS8	SS4	SS1, SS2	Command
OFF	OFF	–	Command specified by J02
OFF	ON	–	Multi-frequency by C08
ON	OFF	–	Multi-frequency by C12
ON	ON	–	Multi-frequency by C16

C08, C12, and C16 can be specified in increments of 1 Hz. The following gives the conversion formula between the PID command value and the data to be specified.

$$\text{Data to be specified} = \text{PID command (\%)} \times \text{Maximum frequency (F03)} \div 100$$

$$\text{PID command (\%)} = \frac{\text{Data to be specified (C08, C12, C16)}}{\text{Maximum frequency (F03)}} \times 100$$

- Manual speed command

SS8, SS4	SS2	SS1	Selected frequency command
–	OFF	OFF	Other than multi-frequency
–	OFF	ON	C05 (Multi-frequency 1)
–	ON	OFF	C06 (Multi-frequency 2)
–	ON	ON	C07 (Multi-frequency 3)

C20 Jogging FrequencyH54, H55 (Acceleration/Deceleration Time, Jogging)
d09 to d13 (Speed Control (Jogging))

To jog or inch the motor for positioning a workpiece, specify the jogging conditions using the jogging-related function codes (C20, H54, H55, and d09 through d13) beforehand, make the inverter ready for jogging, and then enter a run command.



■ **Making the inverter ready for jogging**



Turning ON the "Ready for jogging" terminal command **JOG** (Function code data = 10) readies the inverter for jogging.

Pressing the "STOP" + "▲" keys simultaneously in Running mode also readies the inverter for jogging (when the run command source is "Keypad" (F02 = 0, 2 or 3)). Pressing these keys toggles between "ready for jogging" and "normal operation."

 **Note** Switching between the normal operation state and ready-to-jog state is possible only when the inverter is stopped.

■ **Starting jogging**

Holding down the  or  key or turning the input terminal command **FWD** or **REV** ON jogs the motor.

In jogging with the  or  key, the inverter jogs only when the key is held down. Releasing the key decelerates the motor to a stop.

 **Note** To start jogging operation by simultaneously entering the **JOG** terminal command and a run command (e.g., **FWD**), the input delay time between the two commands should be within 100 ms. If a run command **FWD** is entered first, the inverter does not jog the motor but runs it ordinarily until the next input of the **JOG**.

The jogging conditions should be specified beforehand using the following function codes.

Function code		Data setting range	Description
C20	Jogging Frequency	0.00 to 500.00 Hz	Reference frequency for jogging operation
H54	Acceleration Time (Jogging)	0.00 to 6000 s	Acceleration time for jogging operation
H55	Deceleration Time (Jogging)	0.00 to 6000 s	Deceleration time for jogging operation
d09	Speed Control (Jogging) (Speed command filter)	0.000 to 5.000 s	Modification items related to speed control for jogging operation under vector control without/with speed sensor For adjustments, refer to the descriptions of d01 to d06.
d10	Speed Control (Jogging) (Speed detection filter)	0.000 to 0.100 s	
d11	Speed Control (Jogging) P (Gain)	0.1 to 200.0 times	
d12	Speed Control (Jogging) I (Integral time)	0.001 to 9.999 s	
d13	Speed Control (Jogging) (Output filter)	0.000 to 0.100 s	

C30 Frequency Command 2

(Refer to F01.)

C31 to C35 Analog Input Adjustment for [12] (Offset, Gain, Filter time constant, Gain base point, Polarity)

C36 to C39 Analog Input Adjustment for [C1] (Offset, Gain, Filter time constant, Gain base point)

C41 to C45 Analog Input Adjustment for [V2] (Offset, Gain, Filter time constant, Gain base point, Polarity)

(For details about the frequency command, refer to F01 (Frequency Command 1).)

Setting up a reference frequency using analog input

Adjust the gain, polarity, filter time constant, and offset which are applied to analog inputs (voltage inputs to terminals [12] and [V2], and current input to terminal [C1])

Adjustable items for analog inputs

Input terminal	Input range	Gain		Polarity	Filter time constant	Offset
		Gain	Base point			
[12]	0 to +10 V, -10 to +10 V	C32	C34	C35	C33	C31
[C1]	4 to 20 mA	C37	C39	—	C38	C36
[V2]	0 to +10 V, -10 to +10 V	C42	C44	C45	C43	C41

■ **Offset (C31, C36, C41)**

Data setting range: -5.0 to +5.0 (%)

C31, C36 or C41 configures an offset for an analog voltage/current input. The offset also applies to signals sent from the external equipment.

■ **Filter time constant (C33, C38, C43)** Data setting range: 0.00 to 5.00 (s)

C33, C38 or C43 configures a filter time constant for an analog voltage/current input. The larger the time constant, the slower the response. Specify the proper filter time constant taking into account the response speed of the machine (load). If the input voltage fluctuates due to line noise, increase the time constant.

■ **Polarity (C35, C45)**

C35 and C45 configure the input range for analog input voltage.

Data for C35 and C45	Specifications for terminal inputs
0	-10 to +10 V
1	0 to +10 V (A minus component of the input will be regarded as 0 VDC.)

■ **Gain**

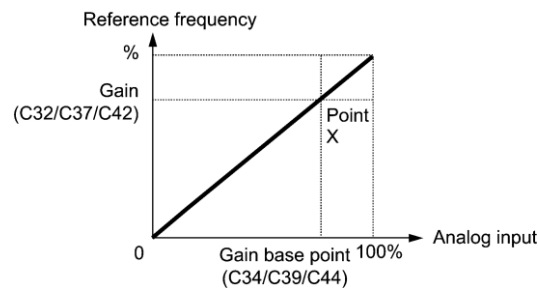

Note To input bipolar analog voltage (0 to ±10 VDC) to terminals [12] and [V2], set C35 and C45 data to "0." Setting C35 and C45 data to "1" enables the voltage range from 0 to +10 VDC and interprets the negative polarity input from 0 to -10 VDC as 0 V.

C40 Terminal [C1] Range Selection

C40 specifies the range of the input current signal on terminal [C1] as listed below.

Data for C40	Range of Input Current Signal on Terminal [C1]
0	4 to 20 mA
1	0 to 20 mA

C50 Bias (Frequency command 1) (Bias base point)

(Refer to F01.)

C51, C52 Bias (PID command 1) (Bias value and Bias base point)

These function codes (and the gain-related function codes) specify the gain and bias of the analog PID command 1, enabling it to define arbitrary relationship between the analog input and PID commands.

Note The actual setting is the same as that of F18. For details, refer to F18 given in the description of F01.

Note Gain-related function codes C32, C34, C37, C39, C42, and C44 are shared by frequency commands.

■ **Bias value (C51)** Data setting range: -100.00 to 100.00 (%)

■ **Bias base point (C52)** Data setting range: 0.00 to 100.00 (%)

C53 Selection of Normal/Inverse Operation (Frequency command 1)

(Refer to E01 to E07.)

4.2.4 P codes (Motor 1 Parameters)

The EQ7 drives the motor under V/f control, dynamic torque control, vector control without speed sensor, or vector control with speed sensor, which can be selected with function codes.

To use the integrated automatic control functions such as auto torque boost, torque calculation monitoring, auto-energy saving operation, torque limiter, automatic deceleration (anti-regenerative control), auto search for idling motor speed, slip compensation, torque vector control, droop control, and overload stop, it is necessary to build a motor model in the inverter by specifying proper motor parameters including the motor capacity and rated current.

The EQ7 provides built-in motor parameters for HP matched motors. To use these motors, it is sufficient to specify motor parameters for P99 (Motor 1 Selection). If the cabling between the inverter and the motor is long (generally, 66 ft (20 m) or longer) or a reactor is inserted between the motor and the inverter, however, the apparent motor parameters will change, so auto-tuning or other adjustments are necessary. For the auto-tuning procedure, refer to Chapter 3 "RUNNING THE MOTOR."

When using a motor made by other manufacturers or a non-standard motor, obtain the datasheet of the motor and specify the motor parameters manually or perform auto-tuning.

To specify the motor parameters correctly, select the motor type with P99 (Motor 1 Selection), specify the motor rated capacity with P02, and then initialize the motor parameters with H03. This procedure also applies when the inverter is switched to the MD/HD mode and a motor with one or two ranks lower capacity is used. When switching the motor between the 1st to 4th motors, specify the corresponding function codes. (Refer to the description of A42.)

The motor parameters to be specified in P13 through P56 (such as iron loss factors and magnetic saturation factors) are usually not shown on the motor nameplate or in the test report.

If auto-tuning (P04 = 2 or 3) is not performed, it is not necessary to change the motor parameters from the ones for a standard motor.

P01 Motor 1 (No. of poles)

P01 specifies the number of poles of the motor. Enter the value given on the nameplate of the motor. This setting is used to monitor the motor speed (see E43) and control the speed. The following expression is used for the conversion.

$$\text{Motor speed (r/min)} = \frac{120}{\text{No. of poles}} \times \text{Frequency (Hz)}$$

- Data setting range: 2 to 22 (poles)

P02 Motor 1 (Rated capacity)

P02 specifies the rated capacity of the motor. Enter the rated value given on the nameplate of the motor.

Data for P02	Unit	Function
0.01 to 1000	HP	When P99 (Motor 1 Selection) = 1
	kW	When P99 (Motor 1 Selection) = 0, 2, 3 or 4

When accessing function code P02 with the keypad, take into account that the P02 data automatically updates the data of function codes P03, P06 through P23, P53 through P56, and H46.

P03 Motor 1 (Rated current)

P03 specifies the rated current of the motor. Enter the rated value given on the nameplate of the motor.

- Data setting range: 0.00 to 2000 (A)

P04 Motor 1 (Auto-tuning)

The inverter automatically detects the motor parameters and saves them in its internal memory. Basically, it is not necessary to perform tuning when using a HP rating motor with a standard connection with the inverter.

There are three types of auto-tuning as listed below. Select appropriate one considering the limitations in your equipment and control mode.

Data for P04	Auto-tuning	Operation	Motor parameters to be tuned
0	Disable	N/A	N/A
1	Tune while the motor stops	The inverter performs tuning while the motor is stopped.	Primary resistance (%R1) (P07) Leakage reactance (%X) (P08) Rated slip frequency (P12) %X correction factors 1 and 2 (P53 and P54)
2	Tune while the motor is rotating under V/f control	After tuning while the motor is stopped, the inverter performs tuning again, with the motor running at 50% of the base frequency.	No-load current (P06) Primary resistance (%R1) (P07) Leakage reactance (%X) (P08) Rated slip frequency (P12) Magnetic saturation factors 1 to 5 (P16 to P20) Magnetic saturation extension factors "a" to "c" (P21 through P23) %X correction factors 1 and 2 (P53 and P54)
3	Tune while the motor is rotating under vector control	After tuning while the motor is stopped, the inverter performs tuning, with the motor running at 50% of the base frequency twice.	No-load current (P06) Primary resistance (%R1) (P07) Leakage reactance (%X) (P08) Rated slip frequency (P12) Magnetic saturation factors 1 to 5 (P16 to P20) Magnetic saturation extension factors "a" to "c" (P21 to P23) %X correction factors 1 and 2 (P53 and P54)

 For details of auto-tuning, refer to Chapter 5, "Check Motor Rotation and Direction".

 **Note** In any of the following cases, perform auto-tuning since the motor parameters are different from those of standard motors so that the best performance cannot be obtained under some controls.

- The motor to be driven is a non-standard motor.
- Cabling between the motor and the inverter is long. (Generally, 66 ft (20 m) or longer)
- A reactor is inserted between the motor and the inverter.

■ Functions that are affected by motor parameters in running capability

Function	Related function codes (representative)
Auto torque boost	F37
Output torque monitor	F31, F35
Load factor monitor	F31, F35
Auto energy saving operation	F37
Torque limiter	F40, F41
Anti-regenerative control (Automatic deceleration)	H69
Auto search	H09
Slip compensation	F42
Dynamic torque control	F42
Droop control	H28
Torque detection	E78 to E81
Vector control without/with speed sensor	F42
Brake Signal (Brake-OFF torque)	J95

P05, A19 Motor 1 / 2 (Online tuning)

Long run under "Dynamic torque control" or "Slip compensation control" causes motor temperature change, varying the motor parameters. This changes the motor speed compensation amount, resulting in motor speed deviation from the initial rotating speed.

Enabling online tuning identifies motor parameters covering the motor temperature change to decrease the motor speed fluctuation.

To perform online tuning enabled with P05/A19, set P04 (Auto-tuning) to "2."

 Note: Online tuning can be performed only when F42 = 1 (Dynamic torque control) or when F42 = 2 (V/f control with slip compensation active) and F37 = 2 or 5 (Auto torque boost).

**A46, d04 Speed Control 2, Speed Control 1,
d12 Speed Control (Jogging) (Integral time)**

These function codes are used to configure the Automatic Speed Regulator (ASR) by selecting the PI controller or P controller.

Setting the function code data to "999" selects the P controller.

P06 to P08 Motor 1 (No-load current, %R1 and %X)

P06 through P08 specify no-load current, %R1 and %X, respectively. Obtain the appropriate values from the test report of the motor or by calling the manufacturer of the motor.

Performing auto-tuning automatically sets these parameters.

■ No-load current (P06)

Enter the value obtained from the motor manufacturer.

■ %R1 (P07)

Enter the value calculated by the following expression.

$$\%R1 = \frac{R1 + \text{Cable } R1}{V / (\sqrt{3} \times I)} \times 100 (\%)$$

where,

R1: Primary resistance of the motor (Ω)

Cable R1: Resistance of the output cable (Ω)

V: Rated voltage of the motor (V)

I: Rated current of the motor (A)

■ %X (P08)

Enter the value calculated by the following expression.

$$\%X = \frac{X1 + X2 \times XM / (X2 + XM) + \text{Cable } X}{V / (\sqrt{3} \times I)} \times 100 (\%)$$

where,

X1: Primary leakage reactance of the motor (Ω)

X2: Secondary leakage reactance of the motor (converted to primary) (Ω)

XM: Exciting reactance of the motor (Ω)

Cable X: Reactance of the output cable (Ω)

V: Rated voltage of the motor (V)

I: Rated current of the motor (A)

 Note For reactance, use the value at the base frequency (F04).

P09 to P11 Motor 1 (Slip compensation gain for driving, Slip compensation response time, and Slip compensation gain for braking)

P09 and P11 determine the slip compensation amount in % for driving and braking individually and adjust the slip amount from internal calculation. Specification of 100% fully compensates for the rated slip of the motor. Excessive compensation (P09, P11 > 100%) may cause hunting (undesirable oscillation of the system), so carefully check the operation on the actual machine.

P10 determines the response time for slip compensation. Basically, there is no need to modify the default setting. If you need to modify it, consult your TECO-Westinghouse Motor Company representatives.

Function codes		Operation (Slip compensation)
P09	Slip compensation gain for driving	Adjust the slip compensation amount for driving. Slip compensation amount for driving = Rated slip x Slip compensation gain for driving
P11	Slip compensation gain for braking	Adjust the slip compensation amount for braking. Slip compensation amount for braking = Rated slip x Slip compensation gain for braking
P10	Slip compensation response time	Specify the slip compensation response time. Basically, there is no need to modify the default setting.

 For details about the slip compensation control, refer to the description of F42.

P12 Motor 1 (Rated slip frequency)

P12 specifies rated slip frequency. Obtain the appropriate values from the test report of the motor or by calling the manufacturer of the motor. Performing auto-tuning automatically sets these parameters.

- Rated slip frequency: Convert the value obtained from the motor manufacturer to Hz using the following expression and enter the converted value. (**Note:** The motor rating given on the nameplate sometimes shows a larger value.)

$$\text{Rated slip frequency (Hz)} = \frac{(\text{Synchronous speed} - \text{Rated speed})}{\text{Synchronous speed}} \times \text{Base frequency}$$

 For details about the slip compensation control, refer to the description of F42.

P13 to P15 Motor 1 (Iron loss factors 1 to 3)

P13 to P15 compensates the iron loss caused inside the motor under vector control with speed sensor, in order to improve the torque control accuracy.

The combination of P99 (Motor 1 selection) and P02 (Motor 1 rated capacity) data determines the standard value. Basically, there is no need to modify the setting.

P16 to P20 Motor 1 (Magnetic saturation factors 1 to 5)
P21 to P23 Motor 1 (Magnetic saturation extension factors "a" to "c")

These function codes specify the characteristics of the exciting current to generate magnetic flux inside the motor and the characteristics of the magnetic flux generated.

The combination of P99 (Motor 1 selection) and P02 (Motor 1 rated capacity) data determines the standard value. Performing auto-tuning while the motor is rotating (P04 = 2 or 3) specifies these factors automatically.

P53, P54 Motor 1 (%X correction factors 1 and 2)

P53 and P54 specify the factors to correct fluctuations of leakage reactance (%X).
Basically, there is no need to modify the setting.

P55 Motor 1 (Torque current under vector control)

P55 specifies the rated torque current under vector control without/with speed sensor.
The combination of P99 (Motor 1 selection) and P02 (Motor 1 rated capacity) data determines the standard value.
Basically, there is no need to modify the setting.

P56 Motor 1 (Induced voltage factor under vector control)

P56 specifies the induced voltage factor under vector control without/with speed sensor.
The combination of P99 (Motor 1 Selection) and P02 (Motor 1, Rated capacity) data determines the standard value.
Basically, there is no need to modify the setting.

P99 Motor 1 Selection

P99 specifies the motor type to be used.

Data for P99	Motor type
0	Motor characteristics 0 (Reserved)
1	Motor characteristics 1 (HP rating motors)
2	Motor characteristics 2 (Reserved)
3	Motor characteristics 3 (Reserved)
4	Motor characteristics 4 (kW rating motors)

To select the motor drive control or to run the inverter with the integrated automatic control functions such as auto torque boost and torque calculation monitoring, it is necessary to specify the motor parameters correctly. First select the motor type to be used with P99, specify the motor rated capacity with P02, and then initialize the motor parameters with H03. This process automatically configures the related motor parameters (P01, P03, P06 through P23, P53 through P56, and H46).

The data of F09 (Torque Boost 1), H13 (Restart Mode after Momentary Power Failure (Restart time)), and F11 (Electronic Thermal Overload Protection for Motor 1, Overload detection level) depends on the motor capacity, but the process stated above does not change them. Specify and adjust the data during a test run if needed.

 **Refer to the user manual for function code descriptions not covered in this section.**

Chapter 5 Check Motor Rotation and Direction

This test is to be performed solely from the EQ7 drive keypad. Apply power to the EQ7 drive after all the electrical connections have been made and protective covers have been re-attached. At this point, **DO NOT RUN THE MOTOR**, the keypad should display as shown below in Fig. 5.1 and the speed reference **0.00** should be blinking.

Important: Motor rotation and direction only applies to standard AC motors with a base frequency of 60Hz.



Fig 5.1: Keypad (Stopped)



Fig 5.2: Keypad (Running)

Next use the \uparrow and \downarrow keys to set a speed reference of 10.00 Hz, then press the FWD key, see Fig 5.2.

The motor should now be operating at low speed running in forward (clockwise) direction.

Next press STOP key to stop the motor.

If the motor rotation is incorrect, power down the EQ7 drive.

After the power has been turned OFF, wait at least ten minutes until the charge indicator extinguishes completely before touching any wiring, circuit boards or components.

Using Safety precaution, and referring to Fig.2.23, exchange any two of the three output leads to the motor (U/T1, V/T2 and W/T3). After the wiring change, repeat this step and recheck motor direction.

Chapter 6 Speed Reference Command Configuration

The EQ7 Drive offers users several choices to set the speed reference source. The most commonly used methods are described in the next sections.

Frequency reference command is selected with parameter F01.





F01 **Frequency Command 1**

This function sets the frequency command source.



Setting Range: 0 to 12

To set parameter F01:

- Press **PRG** key, next select **QUICK SET** or **DATA SET** with **UP/DOWN**  and  keys and press the **FUNC/DATA** key.
- In the parameter list move cursor to F01 with **UP/DOWN** keys and press **FUNC/DATA** key to select.

Data for F01	Function
0	Enable  /  keys on the keypad.
1	Enable the voltage input to terminal [12] (0 to ±10 VDC, maximum frequency obtained at ±10 VDC).
2	Enable the current input to terminal [C1] (0 to +20mA, +4 to +20 mA DC, maximum frequency obtained at +20 mA DC). (SW5 on the control PCB should be turned to the C1 side (factory default)).
3	Enable the sum of voltage (0 to ±10 VDC) and current inputs (+4 to +20 mA DC) given to terminals [12] and [C1], respectively. See the two items listed above for the setting range and the value required for maximum frequencies. (SW5 on the control PCB should be turned to the C1 side (factory default).) Note: If the sum exceeds the maximum frequency (F03), the maximum frequency will apply.
5	Enable the voltage input to terminal [V2] (-10 to ±10 VDC, maximum frequency obtained at ±10 VDC).
7	Enable UP and DOWN commands assigned to the digital input terminals. The UP command (any of E01 to E07 = 17) and DOWN command (any of E01 to E07 = 18) should be assigned to any of digital input terminals [X1] to [X7]. For details, refer to the descriptions of E01 through E07.
8	Enable  /  keys on the keypad (balanceless-bumpless switching available).
11	Enable a digital input interface card (option). (For details, refer to the Digital Input Interface Card Instruction Manual.)
12	Enable the "Pulse train input" PIN command assigned to digital input terminal [X7] (E07 = 48), or a PG interface card (option).

6.1 Reference from Keypad (Default Setting, F01 = 0)

Speed reference from digital operator (Keypad) is the default setting. Use the  and  keys to change the speed reference.

6.2 Reference from External Analog Signal (0 - 10V / 0 - 20mA / 4 - 20mA)

Analog Reference: 0 - 10 V (Setting F01 = 1)

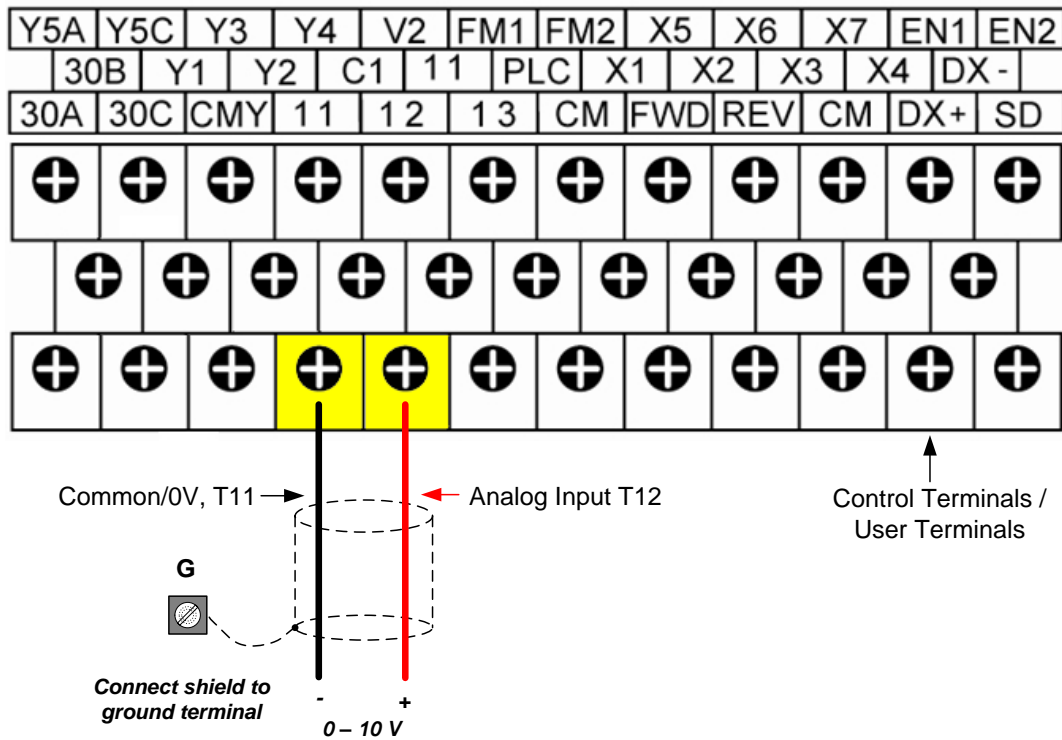

Analog Reference: Potentiometer / Speed Pot (Setting F01 = 1):

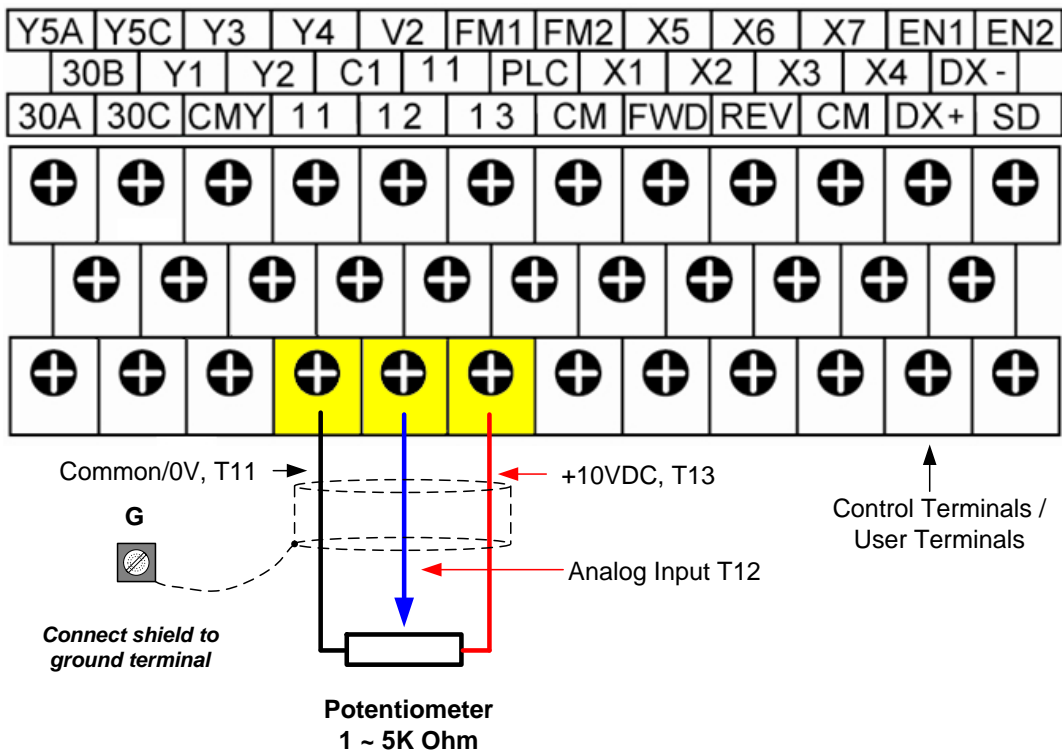

Analog Reference: 0 – 20mA / 4 – 20mA (Setting F01 = 2)

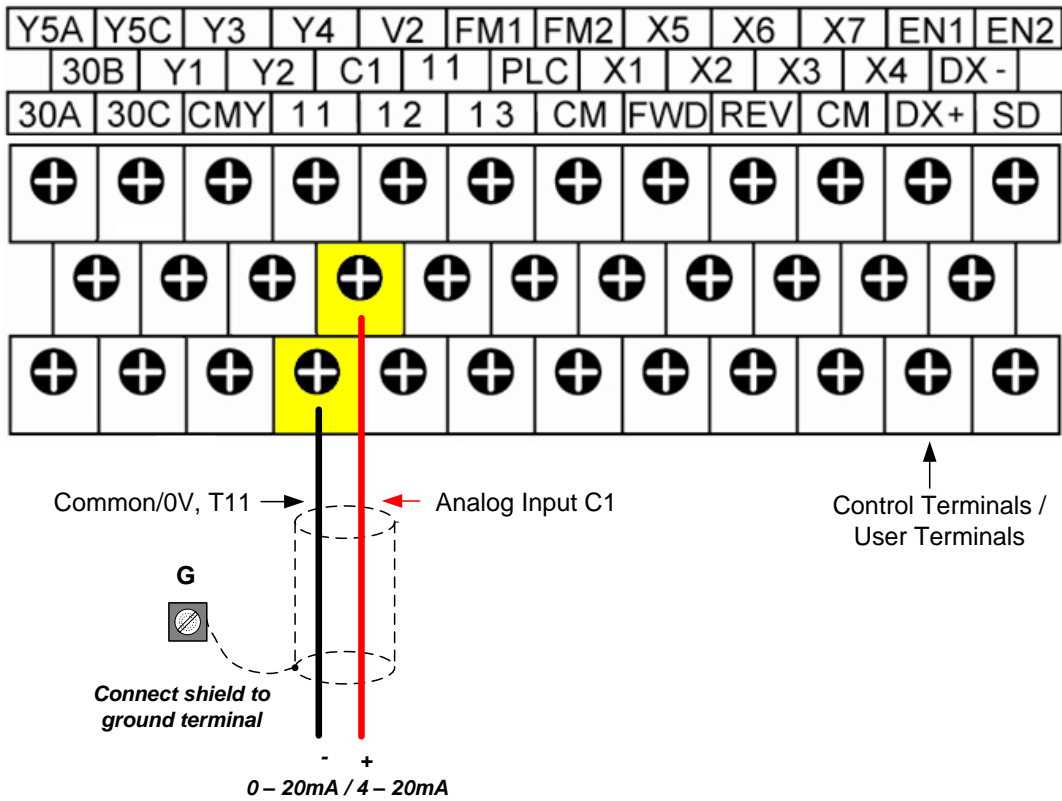

Note: When using a 0 – 20mA signal set parameter C40 to 1.

6.3 Reference from Serial Communication RS485 Port 2 (H30 = 6 or 8)

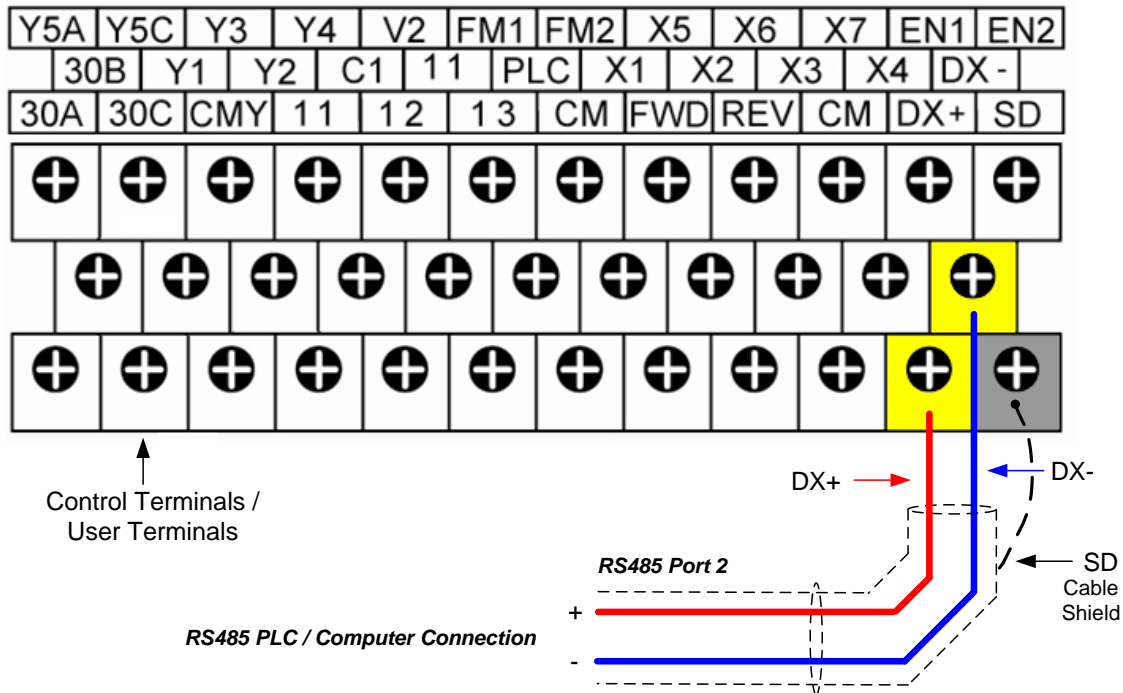

To set the speed reference for the EQ7 drive via serial communication parameter H30 has be set to either a “4” for frequency command via serial communication only or to “8” for Run Command and Frequency Reference (Frequency Command).

Default Communication Setting is: Address “1”, 9600 Bits/sec, 1 Start Bit, 1 Stop Bit, and No Parity

H30 **Communications Link Function**

This function sets the communication link function to select run/stop and frequency reference control.

Setting range: 0 to 8

To set parameter H30:

- Press **PRG** key, next select **QUICK SET** or **DATA SET** with **UP/DOWN**  and  keys and press the **FUNC/DATA** key.
- In the parameter list move cursor to H30 with **UP/DOWN** keys and press **FUNC/DATA** key to select.

The serial communication link function uses RS485 Modbus RTU protocol and allows for:

- 1) Monitoring (data monitoring, function data check).
- 2) Frequency setting.
- 3) Operation command (FWD, REV, and other commands for digital input).
- 4) Write function data.

H30**Communications Link Function**

Set value	Frequency command	Run command (Run/Stop)
0	F01 / C30	F02
1	Enabled / RS485 (Port 1)	F02
2	F01 / C30	Enabled / RS485 (Port 1)
3	Enabled / RS485 (Port 1)	Enabled / RS485 (Port 1)
4	Enabled / RS485 (Port 2)	F02
5	Enabled / RS485 (Port 2)	Enabled / RS485 (Port 1)
6	F01 / C30	Enabled / RS485 (Port 2)
7	Enabled / RS485 (Port 1)	Enabled / RS485 (Port 2)
8	Enabled / RS485 (Port 2)	Enabled / RS485 (Port 2)

Frequency Reference Command Register

EQ7 Drive Frequency Reference Register: 1797 (Decimal) - Bit 0 – Bit 15: 0.00 ~ 120.00 Hz

Examples:**Frequency Reference Command: 10.00 Hz (EQ7 Drive Address: 01)**

Command String (hexadecimal): 01 06 07 05 03 E8 98 01

To set the frequency reference to 10.00, a value of '1000' (03E8h) has to be send to the EQ7 Drive

Frequency Reference Command: 30.00 Hz (EQ7 Drive Address: 01)

Command String (hexadecimal): 01 06 07 05 0B B8 9F FD

To set the frequency reference to 30.00, a value of '3000' (0BB8h) has to be send to the EQ7 Drive

Frequency Reference Command: 60.00 Hz (EQ7 Drive Address: 01)

Command String (hexadecimal): 01 06 07 05 17 70 96 AB

To set the frequency reference to 60.00, a value of '6000' (1770h) has to be send to the EQ7 Drive

Note: The last 2 bytes of the command strings consist of a CRC16 checksum, please refer to the Refer to the EQ7 Communications Manual for additional information.

Chapter 7 Operation Method Configuration (Run / Stop)

The EQ7 Drive offers users several choices to run and stop the drive from different sources. The most commonly used methods are described in the next sections.

F02







Operation Method

This function sets the operation method (Run/Stop) source.

Setting Range: 0 – 3

To set parameter F02:

- Press **PRG** key, next select **QUICK SET** or **DATA SET** with **UP/DOWN**  and  keys and press the **FUNC/DATA** key.
- In the parameter list move cursor to F02 with **UP/DOWN** keys and press **FUNC/DATA** key to select.

Data for F02	Run Command	Description
0	Keypad	Enables the  ,  , and  keys to run the motor in the forward and reverse directions, and stop the motor.
1	Terminal command FWD or REV	Enables input terminal commands FWD and REV to run the motor in the forward and reverse directions, and stop the motor.
2	Keypad (Forward rotation)	Enables the  and  keys to run the motor in the forward direction and stop it. Running the motor in the reverse direction is not possible.
3	Keypad (Reverse rotation)	Enables the  and  keys to run the motor in the reverse direction and stop it. Running the motor in the forward direction is not possible.

7.1 Run/Stop from Keypad (Default Setting, F02 = 0)

Run from digital operator (Keypad) is the default setting.

Use the  key to run the drive in forward direction and the  key to run the EQ7 drive in reverse direction. (Note: to disable reverse direction set parameter H08 to 1)

Press  key to stop the EQ7 drive. (Note: Stop method can be set with parameter H07, default is **ramp to stop**).



7.2 Run/Stop from External Switch / Contact or Pushbutton (F02 = 1)

Use an external contact or switch to Run and Stop the EQ7 drive.

Permanent Switch / Contact

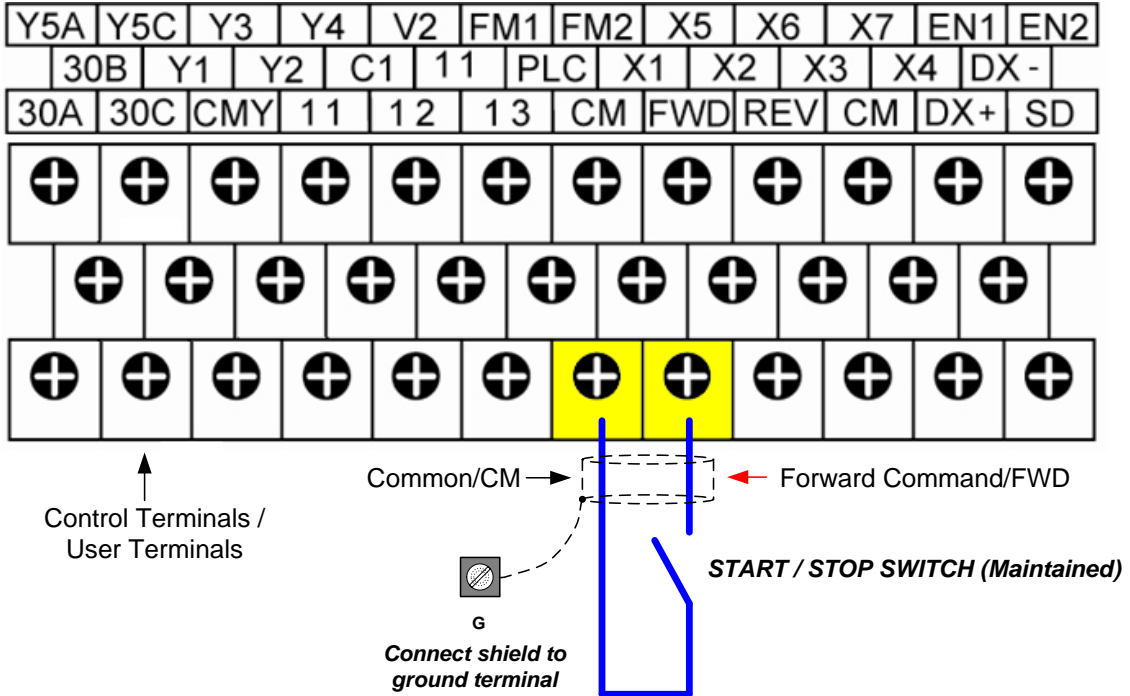

Momentary Contacts (Push Buttons)

Use push button / momentary switch to Run and Stop the EQ7 drive.

F02 Operation Method = 1

E07 Terminal [X7] Function = 6

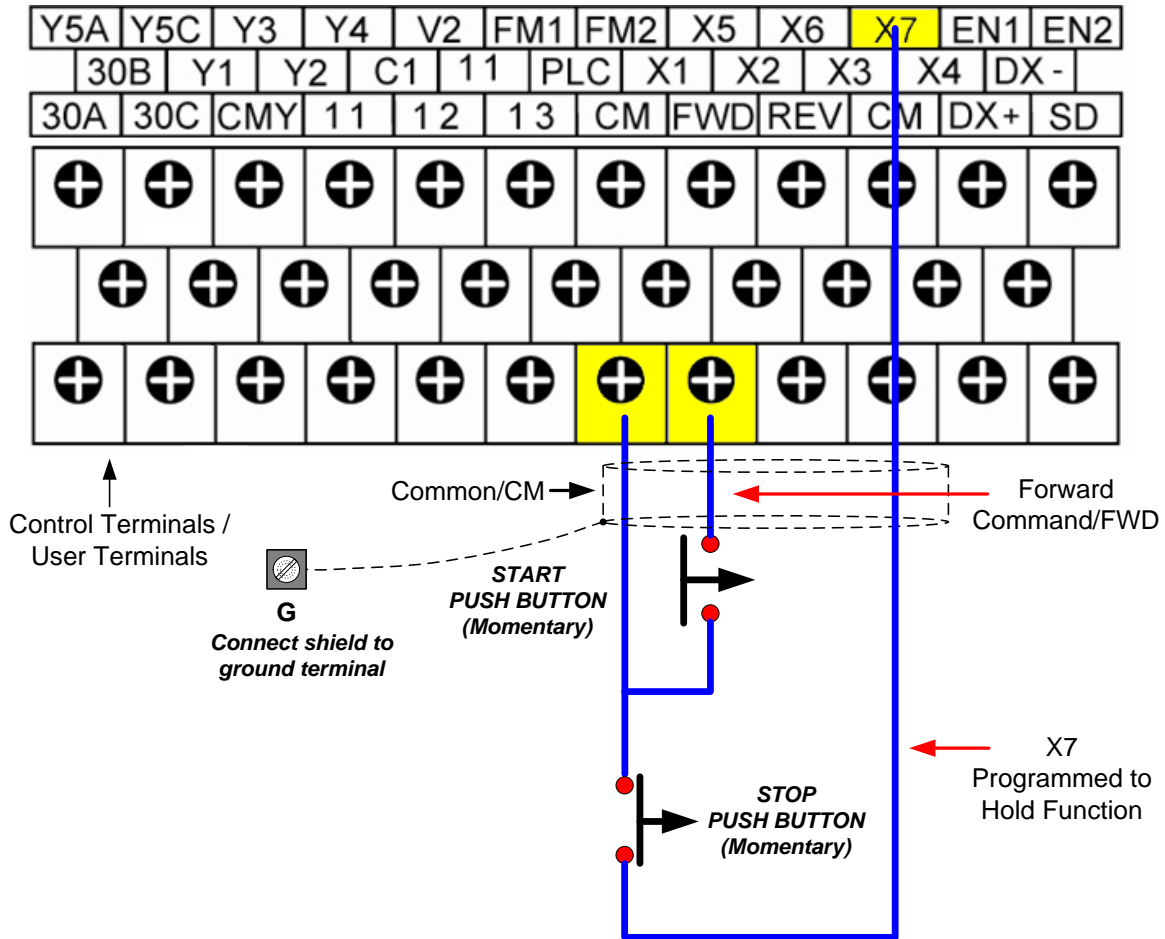

Note: Stop method can be set with parameter H07, default is *ramp to stop*.

7.3 Run/Stop from Serial Communication RS485 Port 2 (H30 = 6 or 8)

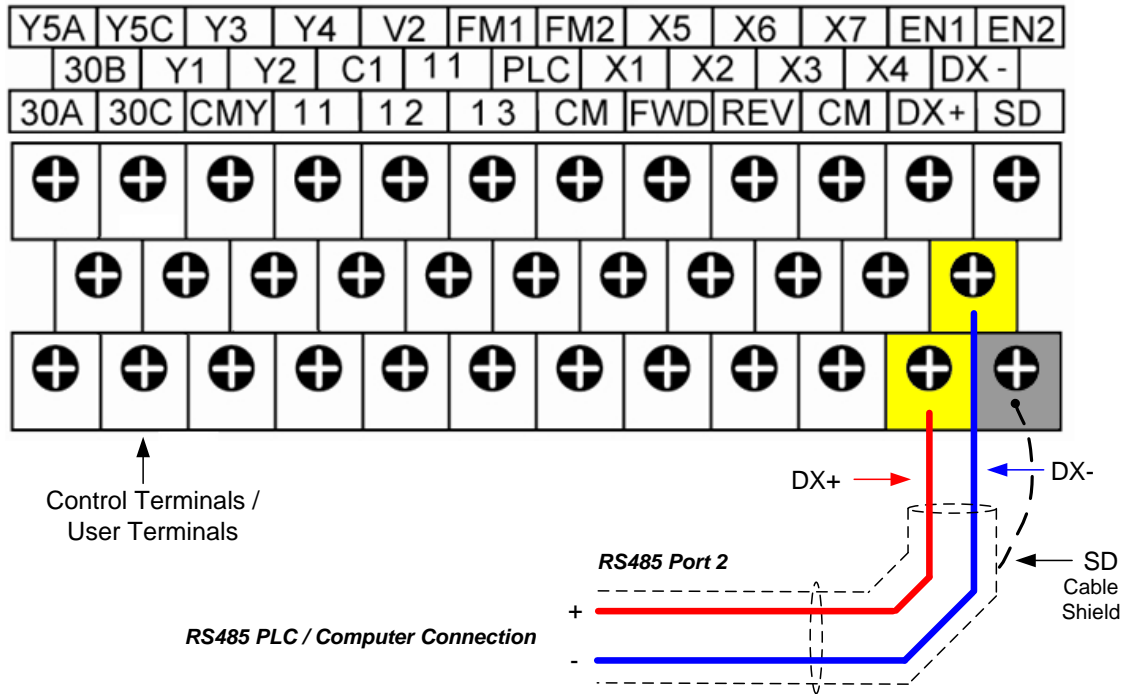

To Run/Stop (Operation Command) the EQ7 drive via serial communication parameter H30 has to be set to either a “6” for Run/Stop via serial communication only or to “8” for Run/Stop (Operation Command) and Frequency Reference (Frequency Command).

Default Communication Setting is: Address “1”, 9600 Bits/sec, 1 Start Bit, 1 Stop Bit, and No Parity

H30 **Communications Link Function**

This function sets the communication link function to select run/stop and frequency reference control.

Setting range: 0 to 8

To set parameter H30:

- Press **PRG** key, next select **QUICK SET** or **DATA SET** with **UP/DOWN**  and  keys and press the **FUNC/DATA** key.
- In the parameter list move cursor to H30 with **UP/DOWN** keys and press **FUNC/DATA** key to select.

The serial communication link function uses RS485 Modbus RTU protocol and allows for:

- 1) Monitoring (data monitoring, function data check).
- 2) Frequency setting.
- 3) Operation command (FWD, REV, and other commands for digital input).
- 4) Write function data.

H30**Communications Link Function**

Set value	Frequency command	Run command (Run/Stop)
0	F01 / C30	F02
1	Enabled / RS485 (Port 1)	F02
2	F01 / C30	Enabled / RS485 (Port 1)
3	Enabled / RS485 (Port 1)	Enabled / RS485 (Port 1)
4	Enabled / RS485 (Port 2)	F02
5	Enabled / RS485 (Port 2)	Enabled / RS485 (Port 1)
6	F01 / C30	Enabled / RS485 (Port 2)
7	Enabled / RS485 (Port 1)	Enabled / RS485 (Port 2)
8	Enabled / RS485 (Port 2)	Enabled / RS485 (Port 2)

Command Register

EQ7 Drive Command Register: 1798 (Decimal)

Bit 0: Run Forward

Bit 1: Run Reverse

Bit 2 ~ Bit 15: Refer to the EQ7 Drive AC Drive Instruction Manual

Examples:**Run Forward Command (EQ7 Drive Address: 01)**

Command String (hexadecimal): 01 06 07 06 00 01 A9 7F

Run Reverse Command (EQ7 Drive Address: 01)

Command String (hexadecimal): 01 06 07 06 00 02 E9 7E

Stop Command (EQ7 Drive Address: 01)

Command String (hexadecimal): 01 06 07 06 00 00 68 BF

Note: The last 2 bytes of the command strings consist of a CRC16 checksum, please refer to the Refer to the EQ7 Communications Manual for additional information.

Chapter 8 Motor and Application Specific Settings

It is essential that before running the motor, the motor nameplate data matches the motor data in the EQ7 drive.

8.1 Set Motor Name Plate Data (P02, P03, F11)

P02

Motor 1 (Capacity)

The nominal motor rated capacity is set at the factory. Please verify that the motor name plate data matches the motor rated capacity shown in parameter P02. The setting should only be changed when driving a motor with a different capacity.

Range: 0.01 to 1000 HP

To set parameter P02:

- Press **PRG** key, next select **QUICK SET or DATA SET** with **UP/DOWN**  and  keys and press the **FUNC/DATA** key.
- In the parameter list move cursor to P02 with **UP/DOWN** keys and press **FUNC/DATA** key to select.

Note: For kW rating motor set P99 to 4.

Default values vary based on the EQ7 drive model.

The motor rated current is set at the factory based on the EQ7 drive model. Enter the motor rated current from the motor nameplate if it does not match the value shown in parameter P3.

P03

Motor 1 (Rated Current)

This function sets the rated current value of motor 1.

Setting range: 0.00 to 2,000A

To set parameter P03:

- Press **PRG** key, next select **QUICK SET or DATA SET** with **UP/DOWN**  and  keys and press the **FUNC/DATA** key.
 - In the parameter list move cursor to P03 with **UP/DOWN** keys and press **FUNC/DATA** key to select.
-

F11

Overload Detection Level

This function sets the operation current level for the electronic thermal O/L. Verify that the motor FLA on the motor nameplate matches the overload level shown in parameter F11

Setting range: 1 to 135% of the rated current of the inverter.

To set parameter F11:

- Press **PRG** key, next select **QUICK SET or DATA SET** with **UP/DOWN**  and  keys and press the **FUNC/DATA** key.
- In the parameter list move cursor to F11 with **UP/DOWN** keys and press **FUNC/DATA** key to select.

8.2 Acceleration and Deceleration Time (F07 / F08)

Acceleration and Deceleration times directly control the system dynamic response. In general, the longer the acceleration and deceleration time, the slower the system response, and the shorter time, the faster the response. An excessive amount of time can result in sluggish system performance while too short of a time may result in system instability.

The default values suggested normally result in good system performance for the majority of general purpose applications. If the values need to be adjusted, caution should be exercised, and the changes should be in small increments to avoid system instability.

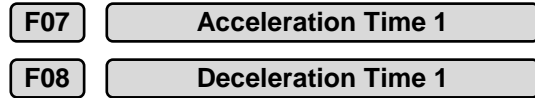

These parameters set the acceleration and deceleration times of the output frequency from 0 to maximum frequency and from maximum frequency to 0.

Setting range: 0.01 to 3600 Sec.

To set parameter F07/F08:

- Press **PRG** key, next select **QUICK SET** or **DATA SET** with **UP/DOWN**  and  keys and press the **FUNC/DATA** key.
- In the parameter list move cursor to F07/F08 with **UP/DOWN** keys and press **FUNC/DATA** key to select.

Acceleration and deceleration times are represented by the three most significant (high order) digits. Set acceleration and deceleration times with respect to maximum frequency. The relationship between the set frequency value and acceleration/deceleration times is as follows:

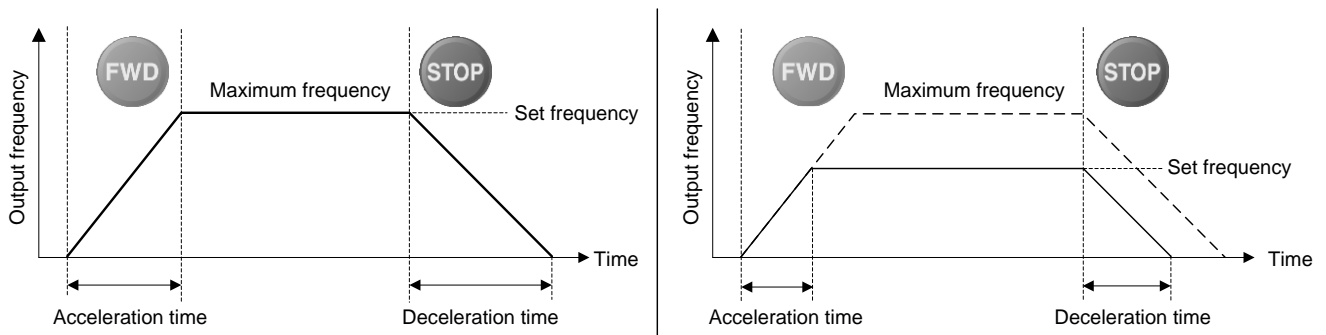

Set Frequency = Maximum Frequency

Set Frequency < Maximum Frequency

Note: If the set acceleration and deceleration times are set too low, the torque limiting function or stall prevention function can become activated if the load torque and or inertia are relatively high. This will prolong the acceleration and or deceleration times and not allow the set times to be followed. In this case the acceleration and or the deceleration times should be adjusted.

8.3 Torque Boost (F09, Default 0.1)

IMPORTANT: PARAMETER IS REQUIRED TO BE CHANGED FOR CONSTANT TORQUE APPLICATIONS.

This parameter sets the relationship between output frequency and output voltage. Constant torque applications have the same torque requirements at low speed as well as at high speed.

See parameter F37 to select Load Selection / Auto Torque Boost.

Initial Setup

For variable Torque / Low Duty applications set parameter F09 to an initial value of 1.0.

For Constant Torque / Medium Duty applications set parameter F09 to an initial value of 2.0.

F09 Torque Boost

This parameter sets the torque boost for motor 1.

Setting range: 0.0 to 20.0

To set parameter F09:

- Press **PRG** key, next select **QUICK SET** or **DATA SET** with **UP/DOWN** (▲) and (▼) keys and press the **FUNC/DATA** key.
- In the parameter list move cursor to F09 with **UP/DOWN** keys and press **FUNC/DATA** key to select.

Setting range	Characteristics selected
0.0	Automatic torque boost characteristic where the torque boost value of a constant torque load (a linear change) is automatically adjusted. The motor tuning (P04 / A13) should be set to "2" for this function to be valid.
0.1 to 0.9	Square law reduction torque for fan and pump loads.
1.0 to 1.9	Proportional torque for middle duty loads between square law reduction torque and constant torque (linear change).
2.0 to 20.0	Constant torque (linear change).

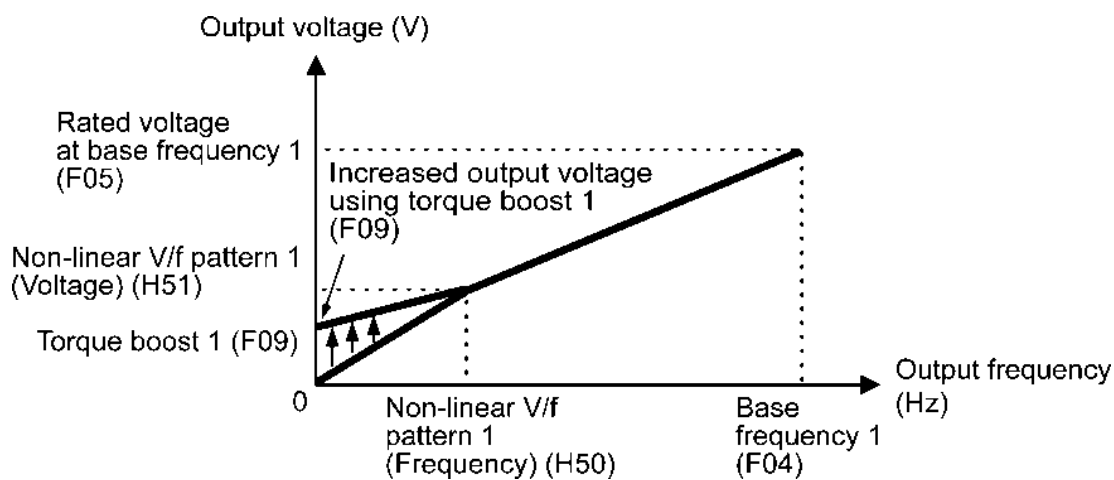

Warning: A larger than required torque boost value creates over-excitation at low speeds, continued operation may cause the motor to overheat. Check the characteristics of the motor for additional information.

8.4 Load Selection / Auto Torque Boost / Auto Energy Saving Operation (F27, Default 1)

This parameter sets the load type and auto torque boost setting, including auto energy savings.

F37 Load Selection / Auto Torque Boost / Auto Energy Saving Operation 1

F37 specifies V/f pattern, torque boost type, and auto energy saving operation in accordance with the characteristics of the load.

Specify the torque boost level with F09 in order to assure sufficient starting torque.

To set parameter F37:

- Press **PRG** key, next select **QUICK SET** or **DATA SET** with **UP/DOWN** \uparrow and \downarrow keys and press the **FUNC/DATA** key.
- In the parameter list move cursor to F37 with **UP/DOWN** keys and press **FUNC/DATA** key to select.

Data for F37	V/f pattern	Torque boost	Auto energy saving	Applicable load
0	Variable torque V/f pattern	Torque boost specified by F09	Disable	Variable torque load (General-purpose fans and pumps)
1	Linear V/f pattern	Auto torque boost		Constant torque load
2			Constant torque load (To be selected if a motor may be over-excited at no load.)	
3	Variable torque V/f pattern	Torque boost specified by F09	Enable	Variable torque load (General-purpose fans and pumps)
4	Linear V/f pattern	Auto torque boost		Constant torque load
5				Constant torque load (To be selected if a motor may be over-excited at no load.)

Note If a required "load torque + acceleration torque" is more than 50% of the constant torque, it is recommended to select the linear V/f pattern (factory default).

Tip Under the vector control with speed sensor, F37 is used to specify whether the auto energy saving operation is enabled or disabled. (V/f pattern and torque boost are disabled.)

Data for F37	Operation
0 to 2	Auto energy saving operation OFF
3 to 5	Auto energy saving operation ON

Under the vector control without speed sensor, both F37 and F09 are disabled. The auto energy saving operation is also disabled.

■ V/f characteristics

The EQ7 series of inverters offers a variety of V/f patterns and torque boosts, which include V/f patterns suitable for variable torque load such as general fans and pumps and for constant torque load (including special pumps requiring high starting torque). Two types of torque boosts are available: manual and automatic.

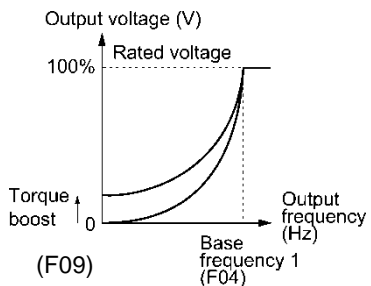

Variable torque V/f pattern (F37 = 0)

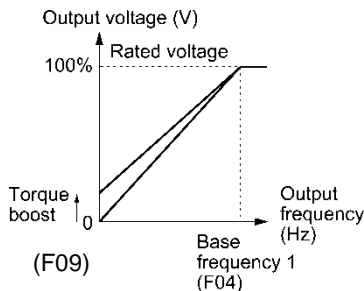

Linear V/f pattern (F37 = 1)



When the variable torque V/f pattern is selected (F37 = 0 or 3), the output voltage may be low at a low frequency zone, resulting in insufficient output torque, depending on the characteristics of the motor and load. In such a case, it is recommended to increase the output voltage at the low frequency zone using the non-linear V/f pattern.

Recommended value: H50 = 1/10 of the base frequency
H51 = 1/10 of the voltage at base frequency

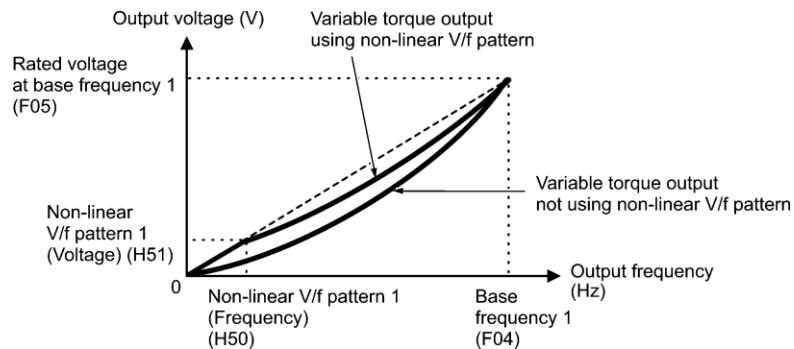

■ Torque boost: Data setting range: 0.0 to 20.0 (%) (100%/Rated voltage at base frequency)

• Auto torque boost

If the auto torque boost is selected, the inverter automatically optimizes the output voltage to fit the motor with its load. Under light load, the inverter decreases the output voltage to prevent the motor from over-excitation. Under heavy load, it increases the output voltage to increase the output torque of the motor.



- Since this function relies also on the characteristics of the motor, set the base frequency 1 (F04), the rated voltage at base frequency 1 (F05), and other pertinent motor parameters (P01 through P03 and P06 through P99) in line with the motor capacity and characteristics, or else perform auto-tuning (P04).
- When a special motor is driven or the load does not have sufficient rigidity, the maximum torque might decrease or the motor operation might become unstable. In such cases, do not use auto torque boost but choose manual torque boost per F09 (F37 = 0 or 1).

■ Auto energy saving operation (H67)

If the auto energy saving operation is enabled, the inverter automatically controls the supply voltage to the motor to minimize the total power loss of motor and inverter. (Note that this feature may not be effective depending upon the motor or load characteristics. Check the advantage of energy saving before you actually apply this feature to your machinery.)

You can select whether applying this feature to constant speed operation only or applying to constant speed operation and accelerating/decelerating operation.

Data for H67	Auto energy saving operation
0	Enable only during running at constant speed
1	Enable during running at constant speed or accelerating/decelerating (Note: For accelerating/decelerating, enable only when the load is light.)

If auto energy saving operation is enabled, the response to a motor speed change from constant speed operation may be slow. Do not use this feature for such machinery that requires quick acceleration/deceleration.



- Use auto energy saving only where the base frequency is 60 Hz or lower. If the base frequency is set at 60 Hz or higher, you may get a little or no energy saving advantage. The auto energy saving operation is designed for use with the frequency lower than the base frequency. If the frequency becomes higher than the base frequency, the auto energy saving operation will be invalid.
- Since this function relies also on the characteristics of the motor, set the base frequency 1 (F04), the rated voltage at base frequency 1 (F05), and other pertinent motor parameters (P01 through P03 and P06 through P99) in line with the motor capacity and characteristics, or else perform auto-tuning (P04).
- Under the vector control without speed sensor, the auto energy saving operation is disabled.

8.5 Reset EQ7 back to Factory Default

Parameter H03 Data Initialization

H03 initializes the current function code data to the factory defaults or initializes the motor parameters.

To change the H03 data, it is necessary to press the $\text{STOP} + \text{▲}$ keys or $\text{STOP} + \text{▼}$ keys (simultaneous keying).

Data for H03	Function
0	Disable initialization (Settings manually made by the user will be retained.)
1	Initialize all function code data to the factory defaults
2	Initialize motor 1 parameters in accordance with P02 (Rated capacity) and P99 (Motor 1 selection)
3	Initialize motor 2 parameters in accordance with A16 (Rated capacity) and A39 (Motor 2 selection)

- To initialize the motor parameters, set the related function codes as follows.

Step	Item	Action	Function code	
			1st motor	2nd motor
(1)	Motor selection	Selects the motor type	P99	A39
(2)	Motor (rated capacity)	Sets the motor capacity (HP)	P02	A16
(3)	Data initialization	Initialize motor parameters	H03 = 2	H03 = 3
Function code data to be initialized		If "Data = 0, 1, 3, or 4" in Step (1)	P01, P03, P06 to P23, P53 to P56, H46	A15, A17, A20 to A37, A53 to A56
		If "Data = 2" in Step (1), function codes listed at the right are also initialized	F04, F05	A02, A03

- Upon completion of the initialization, the H03 data reverts to "0" (factory default).
- If P02 or A16 data is set to a value other than the nominal applied motor rating, data initialization with H03 internally converts the specified value forcibly to the standard nominal applied motor rating. (Refer to Table B in Section 4.1 "Function Code Tables.")
- Motor parameters to be initialized are for motors listed below under V/f control. When the base frequency, rated voltage, and the number of poles are different from those of the listed motors, or when non-standard motors are used, change the rated current data to that printed on the motor nameplate.

Motor selection		V/f control data
Data = 1	TWMC HP rating motors	4 poles 230 V/60 Hz, 460 V/60 Hz
Data = 2	Consult Factory	4 poles —/50 Hz, —/50 Hz
Data = 0 or 4	Consult Factory	4 poles 200 V/50 Hz, 400 V/50 Hz
Data = 3	Consult Factory	4 poles 200 V/50 Hz, 400 V/50 Hz

Note When accessing function code P02 with the keypad, take into account that P02 data automatically updates data of function codes P03, P06 through P23, P53 through P56, and H46. Also, when accessing function code A16, data of related function codes for each are automatically updated.

Chapter 9 Using PID Control for Constant Flow / Pressure Applications

9.1 What is PID Control?

The PID function in the EQ7 drive can be used to maintain a constant process variable such as pressure, flow, temperature by regulating the output frequency (motor speed). A feedback device (transducer) signal is used to compare the actual process variable to a specified setpoint. The difference between the set-point and feedback signal is called the error signal.

The PID control tries to minimize this error to maintain a constant process variable by regulating the output frequency (motor speed).

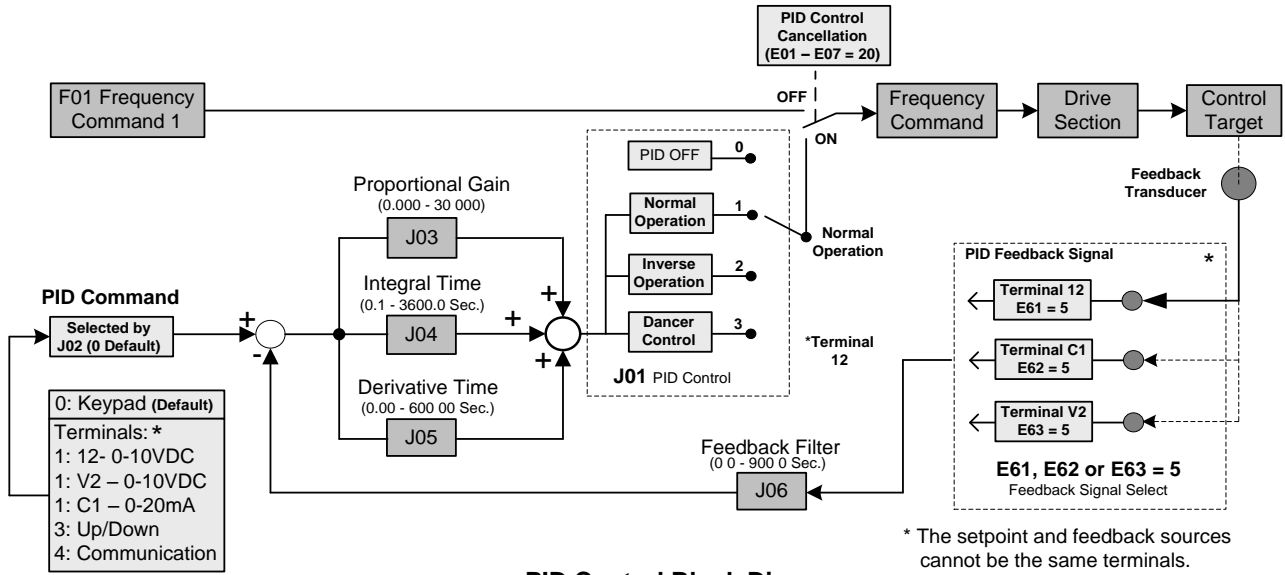

The amplitude of the error can be adjusted with the Proportional Gain parameter J03 and is directly related to the output of the PID controller, so the larger the gain the larger the output correction.

Example 1:

Gain = 1.0
 Set-Point = 80%
 Feedback = 78%
 Error = Set-point - Feedback = 2%
 Control Error = Gain x Error = 2%

Example 2:

Gain = 2.0
 Set-Point = 80%
 Feedback = 78%
 Error = Set-point - Feedback = 2%
 Control Error = Gain x Error = 4%

Please note that an excessive gain can make the system unstable and oscillation may occur.

The response time of the system can be adjusted with the Integral Gain set by parameter J04. Increasing the Integral Time will make the system less responsive and decreasing the Integral Gain Time will increase response but may result in instability of the total system.

Slowing the system down too much may be unsatisfactory for the process. The end result is that these two parameters in conjunction with the acceleration (F07) and deceleration (F08) times (see chapter 8.2) are adjusted to achieve optimum performance for a particular application.

For typical fan and pump applications a Proportional Gain (J03) of 2.0 and an Integral Time (J04) of 5.0 sec is recommended.

J01 **PID control (Mode Select)**

PID control can be enabled by setting parameter J01 to '1'

Setting Range: 0 - 3

- 1) No operation; PID Operation disabled
- 2) Forward operation:
PID operation enabled, motor speeds increases when feedback signal is smaller than set-point (most fan and pump applications)
- 3) Reverse operation:
PID operation enabled, motor slows down when feedback signal is smaller than set-point (e.g. level control applications)

To set parameter J01:

- Press **PRG** key, next select **QUICK SET** or **DATA SET** with **UP/DOWN** ⬆ and ⬇ keys and press the **FUNC/DATA** key.
- In the parameter list move cursor to J01 with **UP/DOWN** keys and press **FUNC/DATA** key to select.

9.2 Connect Transducer Feedback Signal (E61, E62, E63)

Depending on the type of feedback transducer used, the EQ7 drive can be setup for either 0-10V or a 4-20mA feedback transducer.

Feedback Signal 4 – 20mA (Default E62 = 5)

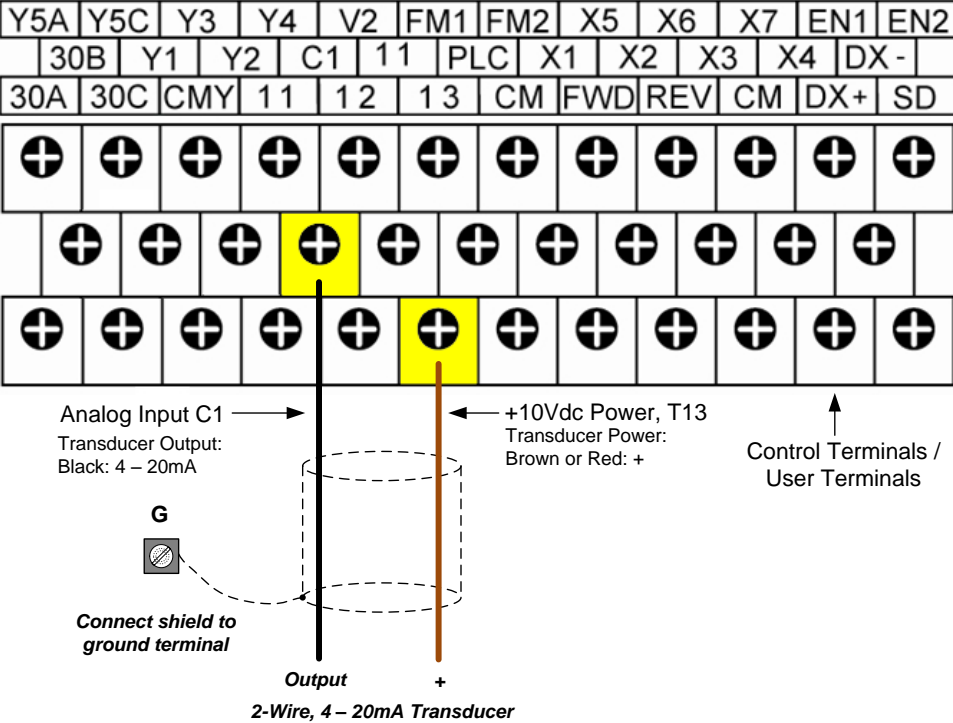

Feedback Signal 0 – 10V (E61 = 5)

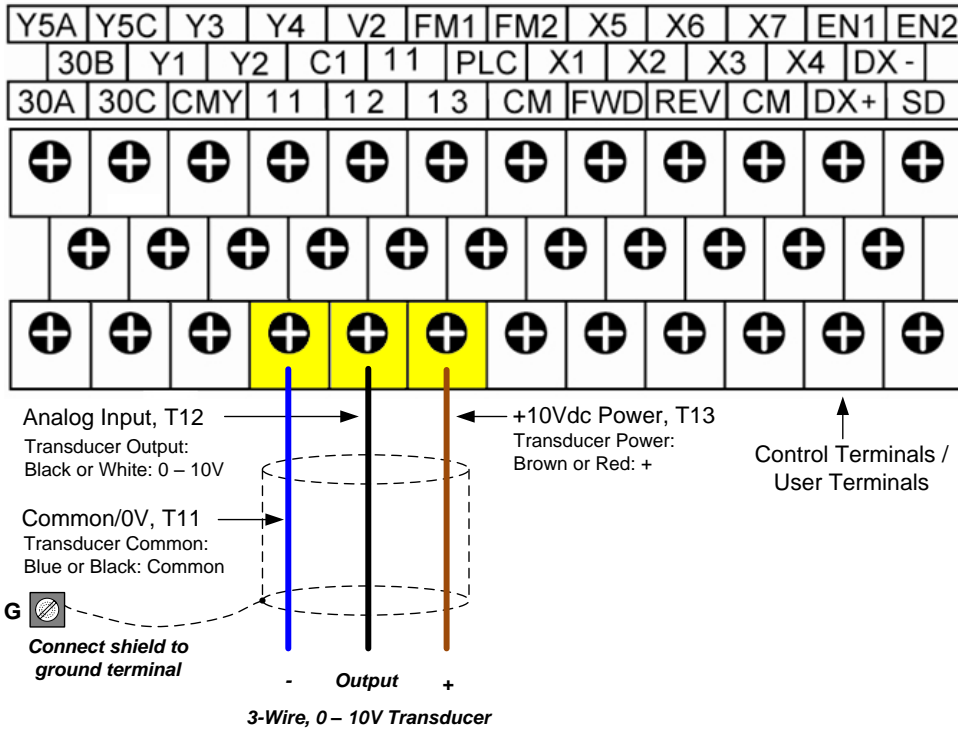

Program Feedback Signal Selection (E61, E62, E63)

Use the extended terminal functions to select the analog terminal to use for the feedback transducer. To do this, determine the transducer specifications and then select the proper input terminal and electrical specifications from the table.

- E61** **Terminal 12 Extended Function**
- E62** **Terminal C1 Extended Function**
- E63** **Terminal V2 Extended Function**

Feedback Signal	Parameter Settings
Terminal 12 (0 – 10V)	E61 = 5
Terminal C1 (4 – 20mA)	E62 = 5
Terminal V2 (-10 – 10V)	E63 = 5

To set parameter E61, E62 and E63:

- Press **PRG** key, next select **QUICK SET** or **DATA SET** with **UP/DOWN** and keys and press the **FUNC/DATA** key.
- In the parameter list move cursor to E61, E62 or E63 with **UP/DOWN** keys and press **FUNC/DATA** key to select.

9.3 Setpoint Scaling / Transducer Feedback Scaling (E40, E41)

Use parameter E40 and E41 to scale the EQ7 set-point to the transducer connected. Parameter E40 has to be programmed to the maximum range of the transducer and E41 to the minimum range of the transducer.

To set parameter E40, E41



- Press **PRG** key, next select **QUICK SET or DATA SET** with **UP/DOWN**  and  keys and press the **FUNC/DATA** key.
- In the parameter list move cursor to E40, E41 with **UP/DOWN** keys and press **FUNC/DATA** key to select.

Example 1:

Transducer range: 0 – 150 PSI
E40 = 150.00
E41 = 0.00 (default)

Example 2:

Transducer range: 0 – 80 PSI
E40 = 80.00
E41 = 0.00 (default)

Use the  and  key to set the PID setpoint value

(E.g. 80.00 PSI)

Refer to the chapter 6 of the Instruction Manual for the preferred command (Run/Stop) method selection.

Chapter 10 Troubleshooting

10.1 Protective Functions

The EQ7 series of inverters has various protective functions as listed below to prevent the system from going down and reduce system downtime. The protective functions marked with an asterisk (*) in the table are disabled by default. Enable them according to your needs.

The protective functions include, for example, the "alarm" detection function which, upon detection of an abnormal state, displays the alarm code on the LED monitor and causes the inverter to trip, the "light alarm" detection function which displays the alarm code but lets the inverter continue the current operation, and other warning signal output functions.

If any problem arises, understand the protective functions listed below and follow the procedures given in Sections 10.2 and onwards for troubleshooting.

Protective function	Description	Related function code
"Alarm" detection	This function detects an abnormal state, displays the corresponding alarm code, and causes the inverter to trip. The "alarm" codes are check-marked in the "Alarm" object column in Table 10.1. For details of each alarm code, see the corresponding item in the troubleshooting. The inverter retains the last four alarm codes and their factors together with their running information applied when the alarm occurred, so it can display them.	H98
"Light alarm" detection*	This function detects an abnormal state categorized as a "light alarm," displays $L-AL$ and lets the inverter continue the current operation without tripping. It is possible to define which abnormal states should be categorized as a "light alarm" using function codes H81 and H82. The "light alarm" codes are check-marked in the "Light alarm" object column in Table 10.1. For how to check and release light alarms, see Section 10.5 "If the "Light Alarm" Indication ($L-AL$) Appears on the LED Monitor."	H81 H82
Stall prevention	When the output current exceeds the current limiter level (F44) during acceleration/ deceleration or constant speed running, this function decreases the output frequency to avoid an overcurrent trip.	F44
Overload prevention control*	Before the inverter trips due to a heat sink overheat ($\Delta H I$) or inverter overload (Olu), this function decreases the output frequency to reduce the load.	H70
Automatic deceleration* (Anti-regenerative control)	If regenerative energy returned exceeds the inverter's braking capability, this function automatically increases the deceleration time or controls the output frequency to avoid an overvoltage trip.	H69
Deceleration characteristics* (Excessive regenerative energy proof braking capability)	During deceleration, this function increases the motor energy loss and decreases the regenerative energy returned to avoid an overvoltage trip (Ou).	H71
Reference loss detection*	This function detects a reference frequency loss (due to a broken wire, etc.), continues the inverter operation at the specified frequency, and issues the "Command loss detected" signal REF OFF .	E65
Automatic lowering of carrier frequency	Before the inverter trips due to an abnormal surrounding temperature or output current, this function automatically lowers the carrier frequency to avoid a trip.	H98
Dew condensation prevention*	Even when the inverter is in stopped state, this function feeds DC current across the motor at certain intervals to raise the motor temperature for preventing dew condensation.	J21
Motor overload early warning*	When the inverter output current has exceeded the specified level, this function issues the "Motor overload early warning" signal OL before the thermal overload protection function causes the inverter to trip for motor protection. This function exclusively applies to the 1st motor.	E34 E35
Auto-reset*	When the inverter has stopped because of a trip, this function allows the inverter to automatically reset and restart itself. (The number of retries and the latency between stop and reset can be specified.)	H04 H05
Forced stop*	Upon receipt of the "Force to stop" terminal command STOP , this function interrupts the run and other commands currently applied in order to forcibly decelerate the inverter to a stop.	H56
Surge protection	This function protects the inverter from a surge voltage invaded between main circuit power lines and the ground.	--

Table 10.1 Abnormal States Detectable ("Alarm" and "Light Alarm" Objects)

Code	Name	"Alarm" objects	"Light alarm" objects	Remarks	Ref. page
<i>OC 1, OC 2, OC 3</i>	Instantaneous overcurrent	√	--		10-12
<i>EF</i>	Ground fault	√	--	50 HP or above	10-12
<i>OU 1, OU 2, OU 3</i>	Overvoltage	√	--		10-12
<i>LU</i>	Undervoltage	√	--		10-13
<i>L in</i>	Input phase loss	√	--		10-14
<i>OPI</i>	Output phase loss	√	--		10-14
<i>OH 1</i>	Heat sink overheat	√	√		10-14
<i>OH 2</i>	External alarm	√	√		10-15
<i>OH 3</i>	Inverter internal overheat	√	√		10-15
<i>OH 4</i>	Motor protection (PTC/NTC thermistor)	√	--		10-16
<i>dbH</i>	Braking resistor overheat	√	√	40 HP or below	10-16
<i>FUS</i>	Fuse blown	√	--	125 HP or above for 230 V series 150 HP or above for 460 V series	10-17
<i>PbF</i>	Charger circuit fault	√	--	60 HP or above for 230 V series 125 HP or above for 460 V series	10-17
<i>OL 1 to OL 2</i>	Overload of motor 1 through 2	√	√		10-17
<i>OLU</i>	Inverter overload	√	--		10-18
<i>OS</i>	Overspeed	√	--		10-18
<i>PG</i>	PG wire break	√	--		10-19
<i>Er 1</i>	Memory error	√	--		10-19
<i>Er 2</i>	Keypad communications error	√	--		10-19
<i>Er 3</i>	CPU error	√	--		10-20
<i>Er 4</i>	Option communications error	√	√		10-20
<i>Er 5</i>	Option error	√	√		10-20
<i>Er 6</i>	Operation protection	√	--		10-20
<i>Er 7</i>	Tuning error	√	--		10-21
<i>ErB</i>	RS-485 communications error (COM port 1)	√	√		10-21
<i>ErP</i>	RS-485 communications error (COM port 2)	√	√		10-21
<i>ErF</i>	Data saving error during undervoltage	√	--		10-22
<i>ErH</i>	Hardware error	√	--	60 HP or above for 230 V series 75 HP or above for 460 V series	10-22
<i>ErE</i>	Speed mismatch or excessive speed deviation	√	√		10-22
<i>Prb</i>	NTC wire break error	√	--		10-23
<i>Err</i>	Mock alarm	√	--		10-23
<i>LoF</i>	PID feedback wire break	√	√		10-24
<i>dbR</i>	Braking transistor broken	√	--		10-24
<i>Er o</i>	Positioning control error	(Servo-lock)	√	--	10-24
		(Synchronous control)	√	√	10-24
<i>ECF</i>	Enable circuit failure	√	--		10-24

Table 10.1 Abnormal States Detectable ("Alarm" and "Light Alarm" Objects) (Continued)

Code	Name	"Alarm" objects	"Light alarm" objects	Remarks	Ref. page
<i>L-AL</i>	Light alarm	--	--		--
<i>FAL</i>	DC fan locked	--	√	75 HP or above for 230 V series 125 HP or above for 460 V series	--
<i>OL</i>	Motor overload early warning	--	√		--
<i>OH</i>	Heat sink overheat early warning	--	√		--
<i>LIF</i>	Lifetime alarm	--	√		--
<i>rEF</i>	Reference command loss detected	--	√		--
<i>Pid</i>	PID alarm	--	√		--
<i>UFL</i>	Low torque output	--	√		--
<i>PFL</i>	PTC thermistor activated	--	√		--
<i>rFE</i>	Inverter life (Motor cumulative run time)	--	√		--
<i>LnI</i>	Inverter life (Number of startups)	--	√		--

10.2 Before Proceeding with Troubleshooting

⚠ WARNING ⚠

If any of the protective functions has been activated, first remove the cause. Then, after checking that the all run commands are set to OFF, release the alarm. If the alarm is released while any run commands are set to ON, the inverter may supply the power to the motor, running the motor.

Injury may occur.

- Even if the inverter has interrupted power to the motor, if the voltage is applied to the main circuit input terminals L1/R, L2/S and L3/T, voltage may be output to inverter output terminals U, V, and W.
- **Turn OFF the power and wait at least five minutes for inverters of 40 HP or below, or at least ten minutes for inverters of 50 HP or above.** Make sure that the LED monitor and charging lamp are turned OFF. Further, make sure, using a multimeter or a similar instrument, that the DC link bus voltage between the terminals P (+) and N (-) has dropped to the safe level (+25 VDC or below).

Electric shock may occur.

Follow the procedure below to solve problems.

(1) First, check that the inverter is correctly wired, referring to Chapter 2, Section 2.3.4 "Wiring of main circuit terminals and grounding terminals."

(2) Check whether an alarm code or the "light alarm" indication ($L - AL$) is displayed on the LED monitor.

- If neither an alarm code nor "light alarm" indication ($L - AL$) appears on the LED monitor

Abnormal motor operation → Go to Section 10.3.1.

[1] The motor does not rotate.

[2] The motor rotates, but the speed does not increase.

[3] The motor runs in the opposite direction to the command.

[4] Speed fluctuation or current oscillation (e.g., hunting) occurs during running at constant speed.

[5] Grating sound is heard from the motor or the motor sound fluctuates.

[6] The motor does not accelerate or decelerate within the specified time.

[7] The motor does not restart even after the power recovers from a momentary power failure.

[8] The motor abnormally heats up.

[9] The motor does not run as expected.

Problems with inverter settings → Go to Section 10.3.2.

[1] Nothing appears on the LED monitor.

[2] The desired menu is not displayed.

[3] Data of function codes cannot be changed.

- If an alarm code appears on the LED monitor → Go to Section 10.4.

- If the "light alarm" indication ($L - AL$) appears on the LED monitor → Go to Section 10.5.

- If an abnormal pattern appears on the LED monitor while neither an alarm code nor "light alarm" indication ($L - AL$) is displayed → Go to Section 10.6.

- For problems that could be caused by running the inverter on single-phase power → Go to Section 10.7.

If any problems persist after the above recovery procedure, contact your TECO-Westinghouse Motor Company representative.

10.3 If Neither an Alarm Code Nor "Light Alarm" Indication (L -HL) Appears on the LED Monitor

This section describes the troubleshooting procedure based on function codes dedicated to motor 1 which are marked with an asterisk (*). For motors 2, replace those asterisked function codes with respective motor dedicated ones (refer to Chapter 4 of the user manual, Section 5.2.6, and Table 5.5).

 For the function codes dedicated to motors 2, see Chapter 4 "FUNCTION CODES."

10.3.1 Abnormal motor operation

[1] The motor does not rotate.

Possible Causes	What to Check and Suggested Measures
(1) No power supplied to the inverter.	<p>Check the input voltage and interphase voltage unbalance.</p> <ul style="list-style-type: none"> ➔ Turn ON a molded case circuit breaker (MCCB), a residual-current-operated protective device (RCD)/earth leakage circuit breaker (ELCB) (with overcurrent protection) or a magnetic contactor (MC). ➔ Check for voltage drop, phase loss, poor connections, or poor contacts, and fix them if necessary. ➔ If only the auxiliary control power input is supplied, also supply the main power to the inverter.
(2) No run forward/reverse command was inputted, or both the commands were inputted simultaneously (external signal operation).	<p>Check the input status of the forward/reverse command with Menu #4 "I/O Checking" using the keypad.</p> <ul style="list-style-type: none"> ➔ Input a run command. ➔ Set either the forward or reverse run command off if both commands are being entered. ➔ Correct the run command source. (Set F02 data to "1.") ➔ Correct the assignment of commands FWD and REV with function codes E98 and E99. ➔ Connect the external circuit wires to control circuit terminals [FWD] and [REV] correctly. ➔ Make sure that the sink/source slide switch (SW1) on the control printed circuit board (control PCB) is properly configured.
(3) No Enable input	<p>Check the input status of terminal [EN] with Menu #4 "I/O Checking" using the keypad.</p> <ul style="list-style-type: none"> ➔ Correct the external circuit wiring to control circuit terminal [EN].
(4) The inverter could not accept any run commands from the keypad since it was in Programming mode.	<p>Check which operation mode the inverter is in, using the keypad.</p> <ul style="list-style-type: none"> ➔ Shift the operation mode to Running mode and enter a run command.
(5) A run command with higher priority than the one attempted was active, and the run command was stopped.	<p>Referring to the block diagram of the frequency command block (given in EQ7 User's Manual, Chapter 6), check the higher priority run command with Menu #2 "Data Checking" and Menu #4 "I/O Checking" using the keypad.</p> <ul style="list-style-type: none"> ➔ Correct any incorrect function code data settings (in H30, y98, etc.) or cancel the higher priority run command.
(6) No analog frequency command input.	<p>Check whether the analog frequency command (reference frequency) is correctly inputted, using Menu #4 "I/O Checking" on the keypad.</p> <ul style="list-style-type: none"> ➔ Connect the external circuit wires to terminals [13], [12], [11], [C1], and [V2] correctly. ➔ When terminal [C1] is used, check the slider position of terminal [C1] property switch (SW5) and the setting of the thermistor mode selection (H26).
(7) The reference frequency was below the starting or stop frequency.	<p>Check that a reference frequency has been entered correctly, using Menu #4 "I/O Checking" on the keypad.</p> <ul style="list-style-type: none"> ➔ Set the reference frequency at the same or higher than that of the starting and stop frequencies (F23* and F25). ➔ Reconsider the starting and stop frequencies (F23* and F25), and if necessary, change them to the lower values. ➔ Inspect the external frequency command potentiometers, signal converters, switches, and relay contacts. Replace any ones that are faulty. ➔ Connect the external circuit wires to terminals [13], [12], [11], [C1], and [V2] correctly.

Possible Causes	What to Check and Suggested Measures
(8) A frequency command with higher priority than the one attempted was active.	Check the higher priority run command with Menu #2 "Data Checking" and Menu #4 "I/O Checking" using the keypad, referring to the block diagram of the frequency command block (refer to the EQ7 User's Manual, Chapter 6). → Correct any incorrect function code data (e.g. cancel the higher priority run command).
(9) The upper and lower frequencies for the frequency limiters were set incorrectly.	Check the data of function codes F15 (Frequency limiter (High)) and F16 (Frequency limiter (Low)). → Change the settings of F15 and F16 to the correct ones.
(10) The coast-to-stop command was effective.	Check the data of function codes E01 through E07, E98, and E99 and the input signal status, using Menu #4 "I/O Checking" on the keypad. → Release the coast-to-stop command setting.
(11) Broken wires, incorrect connection or poor contact with the motor.	Check the wiring (Measure the output current). → Repair the wires to the motor, or replace them.
(12) Overload	Measure the output current. → Reduce the load (In winter, the load tends to increase.)
	Check whether any mechanical brake is activated. → Release the mechanical brake, if any.
(13) Torque generated by the motor was insufficient.	Check that the motor starts running if the value of torque boost (F09*) is increased. → Increase the value of torque boost (F09*) and try to run the motor.
	Check the data of function codes F04*, F05*, H50, H51, H52, H53, H65, and H66. → Change the V/f pattern to match the motor's characteristics.
	Check that the motor switching signal (selecting motor 1, 2, 3 or 4) is correct and the data of function codes matches each motor. → Correct the motor switching signal. → Modify the function code data to match the connected motor.
	Check whether the reference frequency is below the slip-compensated frequency of the motor. → Change the reference frequency so that it becomes higher than the slip-compensated frequency of the motor.
(14) Wrong connection or poor contact of DC reactor (DCR)	Check the wiring. Inverters of 100 HP or above require a DCR to be connected. Without a DCR, these inverters cannot run. → Connect the DCR correctly. Repair or replace DCR wires.

[2] The motor rotates, but the speed does not increase.

Possible Causes	What to Check and Suggested Measures
(1) The maximum frequency currently specified was too low.	Check the data of function code F03* (Maximum frequency). → Correct the F03* data.
(2) The data of frequency limiter (High) currently specified was too low.	Check the data of function code F15 (Frequency limiter (High)). → Correct the F15 data.
(3) The reference frequency currently specified was too low.	Check that the reference frequency has been entered correctly, using Menu #4 "I/O Checking" on the keypad. → Increase the reference frequency. → Inspect the external frequency command potentiometers, signal converters, switches, and relay contacts. Replace any ones that are faulty. → Connect the external circuit wires to terminals [13], [12], [11], [C1], and [V2] correctly.
(4) A frequency command (e.g., multi-frequency or via communications) with higher priority than the one attempted was active and its reference frequency was too low.	Check the data of the relevant function codes and what frequency commands are being received, through Menu #1 "Data Setting," Menu #2 "Data Checking" and Menu #4 "I/O Checking," on the keypad by referring to the block diagram of the frequency command (refer to the EQ7 User's Manual, Chapter 6). → Correct any incorrect data of function codes (e.g. cancel the higher priority frequency command).

Possible Causes	What to Check and Suggested Measures
(5) The acceleration time was too long or too short.	Check the data of function codes F07, E10, E12, and E14 (Acceleration time). → Change the acceleration time to match the load.
(6) Overload.	Measure the output current. → Reduce the load.
	Check whether any mechanical brake is activated. → Release the mechanical brake.
(7) Function code settings do not agree with the motor characteristics.	If auto-torque boost or auto-energy saving operation is specified, check whether the data of P02*, P03*, P06*, P07*, and P08* agree with the parameters of the motor. → Perform auto-tuning of the inverter for the motor to be used.
(8) The output frequency does not increase due to the current limiter operation.	Make sure that F43 (Current limiter (Mode selection)) is set to "2" and check the data of F44 (Current limiter (Level)). → Correct the F44 data. Or, if the current limiter operation is not needed, set F43 to "0" (disabled).
	Decrease the value of torque boost (F09*), then run the motor again and check if the speed increases. → Adjust the value of the torque boost (F09*).
	Check the data of function codes F04*, F05*, H50, H51, H52, H53, H65, and H66 to ensure that the V/f pattern setting is right. → Match the V/f pattern setting with the motor ratings.
(9) The output frequency does not increase due to the torque limiter operation.	Check whether data of torque limiter related function codes (F40, F41, E16 and E17) is correctly configured and the "Select torque limiter level" terminal command TL2/TL1 is correct. → Correct data of F40, F41, E16 and E17 or reset them to the factory defaults (disable). → Set the TL2/TL1 correctly.
(10) Bias and gain incorrectly specified.	Check the data of function codes F18, C50, C32, C34, C37, C39, C42, and C44. → Readjust the bias and gain to appropriate values.

[3] The motor runs in the opposite direction to the command.

Possible Causes	What to Check and Suggested Measures
(1) Wiring to the motor is incorrect.	Check the wiring to the motor. → Connect terminals U, V, and W of the inverter to the U, V, and W terminals of the motor, respectively.
(2) Incorrect connection and settings for run commands and rotation direction commands FWD and REV .	Check the data of function codes E98 and E99 and the connection to terminals [FWD] and [REV]. → Correct the data of the function codes and the connection.
(3) The rotation direction specification of the motor is opposite to that of the inverter.	The rotation direction of IEC-compliant motors is opposite to that of incompliant motors. → Switch the FWD/REV signal setting.

[4] Speed fluctuation or current oscillation (e.g., hunting) occurs during running at constant speed.

Possible Causes	What to Check and Suggested Measures
(1) The frequency command fluctuates.	Check the signals for the frequency command with Menu #4 "I/O Checking" using the keypad. → Increase the filter constants (C33, C38, and C43) for the frequency command.

Possible Causes	What to Check and Suggested Measures
(2) An external potentiometer is used for frequency setting.	Check that there is no noise in the control signal wires from external sources. → Isolate the control signal wires from the main circuit wires as far as possible. → Use shielded or twisted wires for control signals.
	Check whether the external frequency command potentiometer is malfunctioning due to noise from the inverter. → Connect a capacitor to the output terminal of the potentiometer or set a ferrite core on the signal wire. (Refer to Chapter 2.)

Possible Causes	What to Check and Suggested Measures
(3) Frequency switching or multi-frequency command was enabled.	Check whether the relay signal for switching the frequency command is chattering. → If the relay contact is defective, replace the relay.
(4) The wiring length between the inverter and the motor is too long.	Check whether auto-torque boost, auto-energy saving operation, or dynamic torque vector control is enabled. → Perform auto-tuning of the inverter for every motor to be used. → Disable the automatic control systems by setting F37* to "1" (Constant torque load) and F42* to "0" (V/f control with slip compensation active), then check that the motor vibration stops. → Make the output wires as short as possible.
(5) The machinery is hunting due to vibration caused by low rigidity of the load. Or the current is irregularly oscillating due to special motor parameters.	Once disable all the automatic control systems such as auto torque boost, auto energy saving operation, overload prevention control, current limiter, torque limiter, automatic deceleration (anti-regenerative control), auto search for idling motor speed, slip compensation, dynamic torque vector control, droop control, overload stop function, speed control, tuning, notch filter, observer, and then check that the motor vibration comes to a stop. → Disable the functions causing the vibration. → Readjust the output current fluctuation damping gain (H80*). → Readjust the speed control systems. (d01* through d06*)
	Check that the motor vibration is suppressed if you decrease the level of F26 (Motor sound (Carrier frequency)) or set F27 (Motor sound (Tone)) to "0." → Decrease the carrier frequency (F26) or set the tone to "0" (F27 = 0).

[5] Grating sound is heard from the motor or the motor sound fluctuates.

Possible Causes	What to Check and Suggested Measures
(1) The specified carrier frequency is too low.	Check the data of function codes F26 (Motor sound (Carrier frequency)) and F27 (Motor sound (Tone)). → Increase the carrier frequency (F26). → Change the setting of F27 to appropriate value.
(2) The surrounding temperature of the inverter was too high (when automatic lowering of the carrier frequency was enabled by H98).	Measure the temperature inside the panel where the inverter is mounted. → If it is over 40°C (104°F), lower it by improving the ventilation. → Lower the temperature of the inverter by reducing the load. (For fans or pumps, decrease the frequency limiter value (F15).) Note: If you disable H98, an <i>Oh1</i> , <i>Oh3</i> , or <i>OlU</i> alarm may occur.
(3) Resonance with the load.	Check the machinery mounting accuracy or check whether there is resonance with the mounting base. → Disconnect the motor from the machinery and run it alone, then find where the resonance comes from. Upon locating the cause, improve the characteristics of the source of the resonance. → Adjust the settings of C01 (Jump frequency 1) to C04 (Jump frequency (Hysteresis width)) so as to avoid continuous running in the frequency range causing resonance. → Enable the speed control (notch filter) (d07*, d08*) and the observer (d18 to d20) to suppress vibration. (Depending on the characteristics of the load, this may take no effect.)

[6] The motor does not accelerate or decelerate within the specified time.

Possible Causes	What to Check and Suggested Measures
(1) The inverter runs the motor with S-curve or curvilinear pattern.	Check the data of function code H07 (Acceleration/deceleration pattern). → Select the linear pattern (H07 = 0). → Shorten the acceleration/deceleration time (F07, F08, E10 through E15).
(2) The current limiting operation prevented the output frequency from increasing (during acceleration).	Make sure that F43 (Current limiter (Mode selection)) is set to "2: Enable during acceleration and at constant speed," then check that the setting of F44 (Current limiter (Level)) is reasonable. → Readjust the setting of F44 to appropriate value, or disable the function of current limiter with F43. → Increase the acceleration/deceleration time (F07, F08, E10 through E15).
(3) The automatic deceleration (Anti-regenerative control) is enabled during deceleration.	Check the data of function code H69 (Automatic deceleration (Mode selection)). → Increase the deceleration time (F08, E11, E13, and E15).
(4) Overload.	Measure the output current. → Reduce the load (For fans or pumps, decrease the frequency limiter value (F15).) (In winter, the load tends to increase.)
(5) Torque generated by the motor was insufficient.	Check that the motor starts running if the value of the torque boost (F09*) is increased. → Increase the value of the torque boost (F09*).
(6) An external potentiometer is used for frequency setting.	Check that there is no noise in the control signal wires from external sources. → Isolate the control signal wires from the main circuit wires as far as possible. → Use shielded or twisted wires for control signals. → Connect a capacitor to the output terminal of the external frequency command potentiometer or set a ferrite core on the signal wire. (Refer to Chapter 2.)
(7) The output frequency is limited by the torque limiter.	Check whether data of torque limiter related function codes (F40, F41, E16 and E17) is correctly configured and the TL2/TL1 terminal command ("Select torque limiter level 2/1") is correct. → Correct the data of F40, F41, E16 and E17 or reset them to the factory defaults. → Set the TL2/TL1 correctly. → Increase the acceleration/deceleration time (F07, F08, E10 through E15).
(8) The specified acceleration or deceleration time was incorrect.	Check the terminal commands RT1 and RT2 for acceleration/deceleration times. → Correct the RT1 and RT2 settings.

[7] The motor does not restart even after the power recovers from a momentary power failure.

Possible Causes	What to Check and Suggested Measures
(1) The data of function code F14 is either "0," "1," or "2."	Check if an undervoltage trip (<i>lu</i>) occurs. → Change the data of function code F14 (Restart mode after momentary power failure (Mode selection)) to "3," "4," or "5."
(2) The run command remains OFF even after the power has been restored.	Check the input signal with Menu #4 "I/O Checking" using the keypad. → Check the power recovery sequence with an external circuit. If necessary, consider the use of a relay that can keep the run command ON. In 3-wire operation, the power to the control printed circuit board (control PCB) has been shut down once because of a long momentary power failure time, or the "Enable 3-wire operation" signal HOLD has been turned OFF once. → Change the design or the setting so that a run command can be issued again within 2 seconds after the power has been restored.

[8] The motor abnormally heats up.

Possible Causes	What to Check and Suggested Measures
(1) Excessive torque boost specified.	Check whether decreasing the torque boost (F09*) decreases the output current but does not stall the motor. → If no stall occurs, decrease the torque boost (F09*).
(2) Continuous running in extremely slow speed.	Check the running speed of the inverter. → Change the speed setting or replace the motor with a motor exclusively designed for inverters.
(3) Overload.	Measure the inverter output current. → Reduce the load (For fans or pumps, decrease the frequency limiter value (F15).) (In winter, the load tends to increase.)

[9] The motor does not run as expected.



Possible Causes	What to Check and Suggested Measures
(1) Incorrect setting of function code data.	Check that function codes are correctly configured and no unnecessary configuration has been done. → Configure all the function codes correctly.
	Make a note of function code data currently configured and then initialize all function code data using H03. → After the above process, reconfigure function codes one by one, checking the running status of the motor.
(2) Running on single-phase power	→ Refer to Section 10.7 "If the Inverter is Running on Single-Phase Power," [3].

10.3.2 Problems with inverter settings

[1] Nothing appears on the LED monitor.

Possible Causes	What to Check and Suggested Measures
(1) No power (neither main power nor auxiliary control power) supplied to the inverter.	<p>Check the input voltage and interphase voltage unbalance.</p> <ul style="list-style-type: none"> ➔ Turn ON a molded case circuit breaker (MCCB), a residual-current-operated protective device (RCD)/earth leakage circuit breaker (ELCB) (with overcurrent protection) or a magnetic contactor (MC). ➔ Check for voltage drop, phase loss, poor connections, or poor contacts and fix them if necessary.
(2) The power for the control PCB did not reach a sufficiently high level.	<p>Check if the jumper bar has been removed between terminals P1 and P(+) or if there is a poor contact between the jumper bar and those terminals.</p> <ul style="list-style-type: none"> ➔ Mount a jumper bar or a DC reactor between terminals P1 and P(+). For poor contact, tighten up the screws.
(3) The keypad was not properly connected to the inverter.	<p>Check whether the keypad is properly connected to the inverter.</p> <ul style="list-style-type: none"> ➔ Remove the keypad, put it back, and see whether the problem recurs. ➔ Replace the keypad with another one and check whether the problem recurs.
	<p>When running the inverter remotely, ensure that the extension cable is securely connected both to the keypad and to the inverter.</p> <ul style="list-style-type: none"> ➔ Disconnect the cable, reconnect it, and see whether the problem recurs. ➔ Replace the keypad with another one and check whether the problem per recurs.

[2] Data of function codes cannot be changed.

Possible Causes	What to Check and Suggested Measures
(1) An attempt was made to change function code data that cannot be changed when the inverter is running.	<p>Check if the inverter is running with Menu #3 "Drive Monitoring" using the keypad and then confirm whether the data of the function codes can be changed when the motor is running by referring to the function code tables.</p> <ul style="list-style-type: none"> ➔ Stop the motor then change the data of the function codes.
(2) The data of the function codes is protected.	<p>Check the data of function code F00 (Data Protection).</p> <ul style="list-style-type: none"> ➔ Change the F00 data from "Enable data protection" (1 or 3) to "Disable data protection" (0 or 2).
(3) The WE-KP terminal command ("Enable data change with keypad") is not entered, though it has been assigned to a digital input terminal.	<p>Check the data of function codes E01 through E07, E98 and E99 and the input signal status with Menu #4 "I/O Checking" using the keypad.</p> <ul style="list-style-type: none"> ➔ Input a WE-KP command through a digital input terminal.
(4) The  key was not pressed.	<p>Check whether you have pressed the  key after changing the function code data.</p> <ul style="list-style-type: none"> ➔ Press the  key after changing the function code data. ➔ Check that <i>saue</i> is displayed on the LED monitor.
(5) The data of function codes F02, E01 through E07, E98, and E99 cannot be changed.	<p>Either one of the FWD and REV terminal commands is turned ON.</p> <ul style="list-style-type: none"> ➔ Turn OFF both FWD and REV.
(6) The target function code(s) does not appear.	<p>When "0. QUICK SET" is selected, only the particular function code(s) appears.</p> <ul style="list-style-type: none"> ➔ Select "10. USER SET" and add the target function code(s) to the set of function codes registered for Quick Setup. After that, select the target function code(s) and change its data. For details, refer to Chapter 3, Table 3.5 "Menus Available in Programming Mode."

10.4 If an Alarm Code Appears on the LED Monitor

[1] *OCn* Instantaneous overcurrent

Problem The inverter momentary output current exceeded the overcurrent level.

- OC1* Overcurrent occurred during acceleration.
- OC2* Overcurrent occurred during deceleration.
- OC3* Overcurrent occurred during running at a constant speed.

Possible Causes	What to Check and Suggested Measures
(1) The inverter output lines were short-circuited.	Disconnect the wiring from the inverter output terminals ([U], [V] and [W]) and measure the interphase resistance of the motor wiring. Check if the resistance is too low. → Remove the short-circuited part (including replacement of the wires, relay terminals and motor).
(2) Ground faults have occurred at the inverter output lines.	Disconnect the wiring from the output terminals ([U], [V] and [W]) and perform a Megger test. → Remove the grounded parts (including replacement of the wires, relay terminals and motor).
(3) Overload.	Measure the motor current with a measuring device to trace the current trend. Then, use this data to judge if the trend is over the calculated load value for your system design. → If the load is too heavy, reduce it or increase the inverter capacity. Trace the current trend and check if there are any sudden changes in the current. → If there are any sudden changes, make the load fluctuation smaller or increase the inverter capacity. → Enable instantaneous overcurrent limiting (H12 = 1).
(4) Excessive torque boost specified. (when F37* = 0, 1, 3, or 4)	Check whether decreasing the torque boost (F09*) decreases the output current but does not stall the motor. → If no stall occurs, decrease the torque boost (F09*).
(5) The acceleration/ deceleration time was too short.	Check that the motor generates enough torque required during acceleration/deceleration. That torque is calculated from the moment of inertia for the load and the acceleration/deceleration time. → Increase the acceleration/deceleration time (F07, F08, E10 through E15, and H56). → Enable the current limiter (F43) and torque limiter (F40, F41, E16, and E17). → Increase the inverter capacity.
(6) Malfunction caused by noise.	Check if noise control measures are appropriate (e.g., correct grounding and routing of control and main circuit wires). → Implement noise control measures. For details, refer to the EQ7 User's Manual, "Appendix A." → Enable the Auto-reset (H04). → Connect a surge absorber to magnetic contactor's coils or other solenoids (if any) causing noise.

[2] *EF* Ground fault

Problem A ground fault path exists from the output terminal of the inverter.

Possible Causes	What to Check and Suggested Measures
(1) Inverter output terminal(s) grounded (ground fault).	Disconnect the wiring from the output terminals ([U], [V], and [W]) and perform a Megger test. → Remove the grounded parts (including replacement of the wires, relay terminals and motor).

[3] *UVn* Overvoltage

Problem The DC link bus voltage was over the detection level of overvoltage.

- UV1* Overvoltage occurred during acceleration.
- UV2* Overvoltage occurred during deceleration.
- UV3* Overvoltage occurred during running at constant speed.

Possible Causes	What to Check and Suggested Measures
(1) The power supply voltage exceeded the inverter's specification range.	Measure the input voltage. → Decrease the voltage to within the specified range.
Possible Causes	What to Check and Suggested Measures
(2) A surge current entered the input power supply.	In the same power line, if a phase-advancing capacitor is turned ON/OFF or a thyristor converter is activated, a surge (momentary large increase in the voltage or current) may be caused in the input power. → Install a DC reactor.
(3) The deceleration time was too short for the moment of inertia for load.	Recalculate the deceleration torque based on the moment of inertia for the load and the deceleration time. → Increase the deceleration time (F08, E11, E13, E15, and H56). → Enable the automatic deceleration (anti-regenerative control) (H69), or deceleration characteristics (H71). → Enable torque limiter (F40, F41, E16, E17, and H73). → Set the rated voltage (at base frequency) (F05*) to "0" to improve the braking capability. → Consider the use of a braking resistor.
(4) The acceleration time was too short.	Check if the overvoltage alarm occurs after rapid acceleration. → Increase the acceleration time (F07, E10, E12, and E14). → Select the S-curve pattern (H07). → Consider the use of a braking resistor.
(5) Braking load was too heavy.	Compare the braking torque of the load with that of the inverter. → Set the rated voltage (at base frequency) (F05*) to "0" to improve the braking capability. → Consider the use of a braking resistor.
(6) Malfunction caused by noise.	Check if the DC link bus voltage was below the protective level when the overvoltage alarm occurred. → Implement noise control measures. For details, refer to the EQ7 User's Manual, "Appendix A." → Enable the auto-reset (H04). → Connect a surge absorber to magnetic contactor's coils or other solenoids (if any) causing noise.

[4] *LV* Undervoltage

Problem DC link bus voltage has dropped below the undervoltage detection level.

Possible Causes	What to Check and Suggested Measures
(1) A momentary power failure occurred.	→ Release the alarm. → If you want to restart running the motor without treating this condition as an alarm, set F14 to "3," "4," or "5," depending on the load type.
(2) The power to the inverter was switched back to ON too soon (when F14 = 1).	Check if the power to the inverter was switched back to ON while the control power was still alive. (Check whether the LEDs on the keypad light.) → Turn the power ON again after all LEDs on the keypad go off.
(3) The power supply voltage did not reach the inverter's specification range.	Measure the input voltage. → Increase the voltage to within the specified range.
(4) Peripheral equipment for the power circuit malfunctioned, or the connection was incorrect.	Measure the input voltage to find which peripheral equipment malfunctioned or which connection is incorrect. → Replace any faulty peripheral equipment, or correct any incorrect connections.

(5) Any other loads connected to the same power supply has required a large starting current, causing a temporary voltage drop.	Measure the input voltage and check the voltage fluctuation. → Reconsider the power supply system configuration.
(6) Inverter's inrush current caused the power voltage drop because the power supply transformer capacity was insufficient.	Check if the alarm occurs when a molded case circuit breaker (MCCB), residual-current-operated protective device (RCD)/earth leakage circuit breaker (ELCB) (with overcurrent protection) or magnetic contactor (MC) is turned ON. → Reconsider the capacity of the power supply transformer.

[5] L_{in} Input phase loss

Problem Input phase loss occurred, or interphase voltage unbalance rate was large.

Possible Causes	What to Check and Suggested Measures
(1) Breaks in wiring to the main power input terminals.	Measure the input voltage. → Repair or replace the main circuit power input wires or input devices (MCCB, MC, etc.).
(2) The screws on the main power input terminals are loosely tightened.	Check if the screws on the main power input terminals have become loose. → Tighten the terminal screws to the recommended torque.
(3) Interphase voltage unbalance between three phases was too large.	Measure the input voltage. → Connect an AC reactor (ACR) to lower the voltage unbalance between input phases. → Increase the inverter capacity.
(4) Overload cyclically occurred.	Measure the ripple wave of the DC link bus voltage. → If the ripple is large, increase the inverter capacity.
(5) Single-phase voltage was input to the three-phase input inverter.	Check the inverter settings and service condition. → Correct them for single-phase use, referring to Chapter 1, Section 1.3.4 "Precautions for use on single-phase input."
(6) Running on single-phase power	→ Refer to Section 10.7 "If the Inverter is Running on Single-Phase Power," [5].

 Note The input phase loss protection can be disabled with the function code H98 (Protection/Maintenance Function).

[6] DPL Output phase loss

Problem Output phase loss occurred.

Possible Causes	What to Check and Suggested Measures
(1) Inverter output wires are broken.	Measure the output current. → Replace the output wires.
(2) The motor winding is broken.	Measure the output current. → Replace the motor.
(3) The terminal screws for inverter output were not tight enough.	Check if any screws on the inverter output terminals have become loose. → Tighten the terminal screws to the recommended torque.
(4) A single-phase motor has been connected.	→ Single-phase motors cannot be used. Note that the EQ7 only drives three-phase induction motors.

[7] *DH1* Heat sink overheat

Problem Temperature around heat sink has risen abnormally.

Possible Causes	What to Check and Suggested Measures
(1) Temperature around the inverter exceeded the inverter's specification range.	Measure the temperature around the inverter. → Lower the temperature around the inverter (e.g., ventilate the panel where the inverter is mounted).
(2) Ventilation path is blocked.	Check if there is sufficient clearance around the inverter. → Change the mounting place to ensure the clearance.
	Check if the heat sink is not clogged. → Clean the heat sink.
(3) Cooling fan's airflow volume decreased due to the service life expired or failure.	Check the cumulative run time of the cooling fan. Refer to Chapter 3, Section 3.4.6 "Reading maintenance information – Menu #5 "Maintenance Information"." → Replace the cooling fan.
	Visually check whether the cooling fan rotates normally. → Replace the cooling fan.
	Inverters of 60 HP or above for three-phase 230 V series and those of 125 HP or above for three-phase 460 V series are equipped with not only a cooling fan for heat sink but also an internal air circulation fan. Check the following. → Check the connection of the fan power switching connectors "CN R" and "CN W." → Correct the connection. (Refer to "Ⓞ Switching connectors" in Chapter 2, Section 2.3.4 "Wiring of main circuit terminals and grounding terminals".
(4) Overload.	Measure the output current. → Reduce the load (e.g. Use the heat sink overheat early warning (E01 through E07) or the overload early warning (E34) and reduce the load before the overload protection is activated.). → Decrease the motor sound (carrier frequency) (F26). → Enable the overload prevention control (H70).
(5) Running on single-phase power	→ Refer to Section 10.7 "If the Inverter is Running on Single-Phase Power, [1] and [6].

[8] *DH2* External alarm

Problem External alarm was inputted (**THR**).
(when the "Enable external alarm trip" **THR** has been assigned to any of digital input terminals)

Possible Causes	What to Check and Suggested Measures
(1) An alarm function of external equipment was activated.	Check the operation of external equipment. → Remove the cause of the alarm that occurred.
(2) Wrong connection or poor contact in external alarm signal wiring.	Check if the external alarm signal wiring is correctly connected to the terminal to which the "Enable external alarm trip" terminal command THR has been assigned (Any of E01 through E07, E98, and E99 should be set to "9"). → Connect the external alarm signal wire correctly.
(3) Incorrect setting of function code data.	Check whether the "Enable external alarm trip" terminal command THR has been assigned to an unavailable terminal (with E01 through E07, E98, or E99). → Correct the assignment.
	Check whether the normal/negative logic of the external signal matches that of the THR command specified by any of E01 through E07, E98, and E99. → Ensure the matching of the normal/negative logic.

[9] *DH3* Inverter internal overheat

Problem Temperature inside the inverter has exceeded the allowable limit.

Possible Causes	What to Check and Suggested Measures
(1) The surrounding temperature exceeded the inverter's specification limit.	Measure the surrounding temperature. → Lower the temperature around the inverter (e.g., ventilate the panel where the inverter is mounted).
(2) Running on single-phase power	→ Refer to Section 10.7 "If the Inverter is Running on Single-Phase Power," [6].

[10] *dhH* Motor protection (PTC/NTC thermistor)

Problem Temperature of the motor has risen abnormally.

Possible Causes	What to Check and Suggested Measures
(1) The temperature around the motor exceeded the motor's specification range.	Measure the temperature around the motor. → Lower the temperature.
(2) Cooling system for the motor defective.	Check if the cooling system of the motor is operating normally. → Repair or replace the cooling system of the motor.
(3) Overload.	Measure the output current. → Reduce the load (e.g. Use the heat sink overheat early warning (E01 through E07) or the overload early warning (E34) and reduce the load before the overload protection is activated.) (In winter, the load tends to increase.) → Lower the temperature around the motor. → Increase the motor sound (Carrier frequency) (F26).
(4) The activation level (H27) of the PTC thermistor for motor overheat protection was set inadequately.	Check the PTC thermistor specifications and recalculate the detection voltage. → Modify the data of function code H27.
(5) Settings for the PTC/NTC thermistor are improper.	Check the setting of the thermistor mode selection (H26) and the slider position of terminal [C1] property switch SW5. → Change the H26 data in accordance with the thermistor used and set the SW5 to the PTC/NTC position.
(6) Excessive torque boost specified. (F09*)	Check whether decreasing the torque boost (F09*) does not stall the motor. → If no stall occurs, decrease the F09* data.
(7) The V/f pattern did not match the motor.	Check if the base frequency (F04*) and the rated voltage at base frequency (F05*) match the values on the motor's nameplate. → Match the function code data with the values on the motor's nameplate.
(8) Incorrect setting of function code data.	Although no PTC/NTC thermistor is used, the thermistor mode is enabled (H26). → Set the H26 data to "0" (Disable).

[11] *dbH* Braking resistor overheated

Problem The electronic thermal protection for the braking resistor has been activated.

Possible Causes	What to Check and Suggested Measures
(1) Braking load is too heavy.	Reconsider the relationship between the braking load estimated and the real load. → Lower the real braking load. → Review the selection of the braking resistor and increase the braking capability (Modification of related function code data (F50, F51, and F52) is also required.)
(2) Specified deceleration time is too short.	Recalculate the deceleration torque and time needed for the load currently applied, based on a moment of inertia for the load and the deceleration time. → Increase the deceleration time (F08, E11, E13, E15, and H56). → Review the selection of the braking resistor and increase the braking capability. (Modification of related function code data (F50, F51, and F52) is also required.)
(3) Incorrect setting of function code data F50, F51, and F52.	Recheck the specifications of the braking resistor. → Review data of function codes F50, F51, and F52, then modify them.

Note: The inverter issues an overheat alarm of the braking resistor by monitoring the magnitude of the braking load, not by measuring its surface temperature.

When the braking resistor is frequently used so as to exceed the settings made by function codes F50, F51, and F52, therefore, the inverter issues an overheat alarm even if the surface temperature of the braking resistor does not rise. To squeeze out full performance of the braking resistor, configure function codes F50, F51, and F52 while actually measuring the surface temperature of the braking resistor.

[12] FU5 Fuse blown

Problem The fuse inside the inverter blew.

Possible Causes	What to Check and Suggested Measures
(1) The fuse blew due to short-circuiting inside the inverter.	<p>Check whether there has been any excess surge or noise coming from outside.</p> <p>→ Take measures against surges and noise.</p> <p>→ Have the inverter repaired.</p>

[13] P6F Charger circuit fault

Problem The magnetic contactor for short-circuiting the charging resistor failed to work.

Possible Causes	What to Check and Suggested Measures
(1) The control power was not supplied to the magnetic contactor intended for short-circuiting the charging resistor.	<p>Check that, in normal connection of the main circuit (not a connection via the DC link bus), the connector (CN R) on the power printed circuit board (power PCB) is not inserted to [NC].</p> <p>→ Insert the connector (CN R) to [FAN].</p>
	<p>Check whether you quickly turned the circuit breaker ON and OFF to confirm safety after cabling/wiring.</p> <p>→ Wait until the DC link bus voltage has dropped to a sufficiently low level and then release the current alarm. After that, turn ON the power again. (Do not turn the circuit breaker ON and OFF quickly.)</p> <p>(Turning ON the circuit breaker supplies power to the control circuit to the operation level (lighting the LEDs on the keypad) in a short period. Immediately turning it OFF even retains the control circuit power for a time, while it shuts down the power to the magnetic contactor intended for short-circuiting the charging resistor since the contactor is directly powered from the main power.</p> <p>Under such conditions, the control circuit can issue a turn-on command to the magnetic contactor, but the contactor not powered can produce nothing. This state is regarded as abnormal, causing an alarm.)</p>
(2) Running on single-phase power	<p>→ Refer to Section 10.7 "If the Inverter is Running on Single-Phase Power," [4].</p>

[14] OL1 Overload of motor 1, 2

Problem Electronic thermal protection for motor 1, 2 activated.

- OL1 Motor 1 overload
- OL2 Motor 2 overload

Possible Causes	What to Check and Suggested Measures
(1) The electronic thermal characteristics do not match the motor overload characteristics.	<p>Check the motor characteristics.</p> <p>→ Reconsider the data of function codes (P99*, F10* and F12*).</p> <p>→ Use an external thermal relay.</p>
(2) Activation level for the electronic thermal protection was inadequate.	<p>Check the continuous allowable current of the motor.</p> <p>→ Reconsider and change the data of function code F11*.</p>
(3) The specified acceleration/ deceleration time was too short.	<p>Recalculate the acceleration/deceleration torque and time needed for the load, based on the moment of inertia for the load and the acceleration/deceleration time.</p> <p>→ Increase the acceleration/ deceleration time (F07, F08, E10 through E15, and H56).</p>
(4) Overload.	<p>Measure the output current.</p> <p>→ Reduce the load (e.g. Use the overload early warning (E34) and reduce the load before the overload protection is activated.). (In winter, the load tends to increase.)</p>
(5) Excessive torque boost specified (F09*)	<p>Check whether decreasing the torque boost (F09*) does not stall the motor.</p> <p>→ If no stall occurs, decrease the F09* data.</p>

[15] *DLU* Inverter overload

Problem Temperature inside inverter has risen abnormally.

Possible Causes	What to Check and Suggested Measures
(1) Temperature around the inverter exceeded the inverter's specification range.	Measure the temperature around the inverter. → Lower the temperature (e.g., ventilate the panel where the inverter is mounted).
(2) Excessive torque boost specified (F09*)	Check whether decreasing the torque boost (F09*) does not stall the motor. → If no stall occurs, decrease the F09* data.
(3) The specified acceleration/ deceleration time was too short.	Recalculate the acceleration/deceleration torque and time needed for the load, based on the moment of inertia for the load and the acceleration/deceleration time. → Increase the acceleration/deceleration time (F07, F08, E10 through E15, and H56).
(4) Overload.	Measure the output current. → Reduce the load (e.g., Use the overload early warning (E34) and reduce the load before the overload protection is activated.). (In winter, the load tends to increase.) → Decrease the motor sound (Carrier frequency) (F26). → Enable overload prevention control (H70).
(5) Ventilation paths are blocked.	Check if there is sufficient clearance around the inverter. → Change the mounting place to ensure the clearance.
	Check if the heat sink is not clogged. → Clean the heat sink.
(6) Cooling fan's airflow volume decreased due to the service life expired or failure.	Check the cumulative run time of the cooling fan. Refer to Chapter 3, Section 3.4.6 "Reading maintenance information – Menu #5 "Maintenance Information"." → Replace the cooling fan.
	Visually check that the cooling fan rotates normally. → Replace the cooling fan.
(7) The wires to the motor are too long, causing a large leakage current from them.	Measure the leakage current. → Insert an output circuit filter (OFL).
(8) Running on single-phase power	→ Refer to Section 10.7 "If the Inverter is Running on Single-Phase Power," [1] and [6].

[16] *D5* Overspeed

Problem The motor rotates in an excessive speed (Motor speed \geq (F03 data) \times (d32 data, d33 data) \times 1.2)

Possible Causes	What to Check and Suggested Measures
(1) Incorrect setting of function code data.	Check the motor parameter "Number of poles" (P01*). → Specify the P01* data in accordance with the motor to be used.
	Check the maximum frequency setting (F03*). → Specify the F03* data in accordance with the output frequency.
	Check the setting of speed limit function (d32 and d33). → Disable the speed limit function (d32 and d33).
(2) Insufficient gain of the speed controller.	Check whether the actual speed overshoots the commanded one in higher speed operation. → Increase the speed controller gain (d03*). (Depending on the situations, reconsider the setting of the filter constant or the integral time.)
(3) Noises superimposed on the PG wire.	Check whether appropriate noise control measures have been implemented (e.g., correct grounding and routing of signal wires and main circuit wires). → Implement noise control measures. For details, refer to the EQ7 User's Manual, "Appendix A."



[17] *P_G* PG wire break

Problem The pulse generator (PG) wire has been broken somewhere in the circuit.

Possible Causes	What to Check and Suggested Measures
(1) The wire between the pulse generator (PG) and the option card has been broken.	<p>Check whether the pulse generator (PG) is correctly connected to the option card or any wire is broken.</p> <ul style="list-style-type: none"> ➔ Check whether the PG is connected correctly. Or, tighten up the related terminal screws. ➔ Check whether any joint or connecting part bites the wire sheath. ➔ Replace the wire.
(2) PG related circuit affected by strong electrical noise.	<p>Check if appropriate noise control measures have been implemented (e.g., correct grounding and routing of signal wires, communication cables, and main circuit wires).</p> <ul style="list-style-type: none"> ➔ Implement noise control measures. ➔ Separate the signal wires from the main power wires as far as possible.

[18] *E_r 1* Memory error

Problem Error occurred in writing the data to the memory in the inverter.

Possible Causes	What to Check and Suggested Measures
(1) When writing data (especially initializing or copying data), the inverter was shut down so that the voltage to the control PCB has dropped.	<p>Initialize the function code data with H03 (= 1). After initialization, check if pressing the  key releases the alarm.</p> <ul style="list-style-type: none"> ➔ Revert the initialized function code data to their previous settings, then restart the operation.
(2) Inverter affected by strong electrical noise when writing data (especially initializing or copying data).	<p>Check if appropriate noise control measures have been implemented (e.g., correct grounding and routing of control and main circuit wires). Also, perform the same check as described in (1) above.</p> <ul style="list-style-type: none"> ➔ Implement noise control measures. Revert the initialized function code data to their previous settings, then restart the operation.
(3) The control PCB failed.	<p>Initialize the function code data by setting H03 to "1," then reset the alarm by pressing the  key and check that the alarm goes on.</p> <ul style="list-style-type: none"> ➔ The control PCB (on which the CPU is mounted) is defective. Contact your TECO-Westinghouse Motor Company representative.

[19] *E_r 2* Keypad communications error

Problem A communications error occurred between the multi-function keypad and the inverter.

Possible Causes	What to Check and Suggested Measures
(1) Broken communications cable or poor contact.	<p>Check continuity of the cable, contacts and connections.</p> <ul style="list-style-type: none"> ➔ Re-insert the connector firmly. ➔ Replace the cable.
(2) Connecting many control wires hinders the front cover from being mounted, lifting the keypad.	<p>Check the mounting condition of the front cover.</p> <ul style="list-style-type: none"> ➔ Use wires of the recommended size AWG 19 or 18 (0.65 to 0.82 mm²) for wiring. ➔ Change the wiring layout inside the unit so that the front cover can be mounted firmly.
(3) Inverter affected by strong electrical noise.	<p>Check if appropriate noise control measures have been implemented (e.g., correct grounding and routing of communication cables and main circuit wires).</p> <ul style="list-style-type: none"> ➔ Implement noise control measures. <p>For details, refer to the EQ7 User's Manual, "Appendix A."</p>
(4) A keypad failure occurred.	<p>Replace the keypad with another one and check whether a keypad communications error (<i>E_r 2</i>) occurs.</p> <ul style="list-style-type: none"> ➔ Replace the keypad.

[20] Er3 CPU error

Problem A CPU error (e.g. erratic CPU operation) occurred.

Possible Causes	What to Check and Suggested Measures
(1) Inverter affected by strong electrical noise.	Check if appropriate noise control measures have been implemented (e.g. correct grounding and routing of signal wires, communications cables, and main circuit wires). → Implement noise control measures.

[21] Er4 Option communications error

Problem A communications error occurred between the option card and the inverter.



Possible Causes	What to Check and Suggested Measures
(1) There was a problem with the connection between the option card and the inverter.	Check whether the connector on the option card is properly engaged with that of the inverter. → Reload the option card into the inverter.
(2) Strong electrical noise.	Check whether appropriate noise control measures have been implemented (e.g. correct grounding and routing of signal wires, communications cables, and main circuit wires). → Implement noise control measures.

[22] Er5 Option error

An error detected by the option card. Refer to the instruction manual of the option card for details.

[23] Er6 Operation protection

Problem An incorrect operation was attempted.

Possible Causes	What to Check and Suggested Measures
(1) The  key was pressed when H96 = 1 or 3.	Check that the  key was pressed when a run command had been entered from the input terminal or through the communications port. → If this was not intended, check the setting of H96.
(2) The start check function was activated when H96 = 2 or 3.	Check that any of the following operations has been performed with a run command being entered. - Turning the power ON - Releasing the alarm - Switching the enable communications link LE operation → Review the running sequence to avoid input of a Run command when this error occurs. If this was not intended, check the setting of H96. (Turn the run command OFF before releasing the alarm.)
(3) The forced stop digital input STOP was turned OFF.	Check that turning the STOP OFF decelerated the inverter to stop. → If this was not intended, check the settings of E01 through E07 for terminals [X1] through [X7].

[24] Er 7 Tuning error

Problem Auto-tuning failed.

Possible Causes	What to Check and Suggested Measures
(1) A phase was missing (There was a phase loss) in the connection between the inverter and the motor.	→ Properly connect the motor to the inverter.
(2) V/f or the rated current of the motor was not properly set.	Check whether the data of function codes (F04*, F05*, H50 through H53, H65, H66, P02*, and P03*) matches the motor specifications.
(3) The wiring length between the inverter and the motor was too long.	Check whether the wiring length between the inverter and the motor exceeds 164 ft (50 m). (Small capacity inverters are greatly affected by the wiring length.) → Review, and if necessary, change the layout of the inverter and the motor to shorten the connection wire. Alternatively, minimize the wiring length without changing the layout. → Disable both auto-tuning and auto-torque boost (set data of F37* to "1").
(4) The rated capacity of the motor was significantly different from that of the inverter.	Check whether the rated capacity of the motor is three or more ranks lower, or two or more ranks higher than that of the inverter. → Replace the inverter with one with an appropriate capacity. → Manually specify the values for the motor parameters P06*, P07*, and P08*. → Disable both auto-tuning and auto-torque boost (set data of F37* to "1").
(5) The motor was a special type such as a high-speed motor.	→ Disable both auto-tuning and auto-torque boost (set data of F37* to "1").
(6) A tuning operation involving motor rotation (P04* = 2 or 3) was attempted while the brake was applied to the motor.	→ Specify the tuning that does not involve the motor rotation (P04* = 1). → Release the brake before tuning that involves the motor rotation (P04* = 2 or 3).

 For details of tuning errors, refer to Chapter 4 of the user manual, Section 4.1.7 "Function code basic settings and tuning < 2 > , ■ Tuning errors."

**[25] ErB RS-485 communications error (COM port 1)
ErP RS-485 communications error (COM port 2)**



Problem A communications error occurred during RS-485 communications.

Possible Causes	What to Check and Suggested Measures
(1) Communications conditions of the inverter do not match that of the host equipment.	Compare the settings of the y codes (y01 to y10, y11 to y20) with those of the host equipment. → Correct any settings that differ.
(2) Even though no-response error detection time (y08, y18) has been set, communications is not performed within the specified cycle.	Check the host equipment. → Change the settings of host equipment software or disable the no-response error detection (y08, y18 = 0).
(3) The host equipment did not operate due to defective software, settings, or defective hardware.	Check the host equipment (e.g., PLCs and computers). → Remove the cause of the equipment error.
(4) The RS-485 converter did not operate due to incorrect connections and settings, or defective hardware.	Check the RS-485 converter (e.g., check for poor contact). → Change the various RS-485 converter settings, reconnect the wires, or replace hardware with recommended devices as appropriate.
(5) Broken communications cable or poor contact.	Check the continuity of the cables, contacts and connections. → Replace the cable.

Possible Causes	What to Check and Suggested Measures
(6) Inverter affected by strong electrical noise.	Check if appropriate noise control measures have been implemented (e.g., correct grounding and routing of communications cables and main circuit wires). → Implement noise control measures. → Implement noise reduction measures on the host side. → Replace the RS-485 converter with a recommended insulated one.
(7) Terminating resistor not properly configured.	Check that the inverter serves as a terminating device in the network. → Configure the terminating resistor switch(es) (SW2/SW3) for RS-485 communication correctly. (That is, turn the switch(es) to ON.)

[26] *E_rF* Data saving error during undervoltage

Problem The inverter failed to save data such as the frequency commands and PID commands (which are specified through the keypad), or the output frequencies modified by the **UP/DOWN** terminal commands when the power was turned OFF.

Possible Causes	What to Check and Suggested Measures
(1) During data saving performed when the power was turned OFF, the voltage fed to the control PCB dropped in an abnormally short period due to the rapid discharge of the DC link bus.	Check how long it takes for the DC link bus voltage to drop to the preset voltage when the power is turned OFF. → Remove whatever is causing the rapid discharge of the DC link bus voltage. After pressing the  key and releasing the alarm, return the data of the relevant function codes (such as the frequency commands and PID commands (specified through the keypad) or the output frequencies modified by the UP/DOWN terminal commands) back to the original values and then restart the operation.
(2) Inverter operation affected by strong electrical noise when the power was turned OFF.	Check if appropriate noise control measures have been implemented (e.g., correct grounding and routing of control and main circuit wires). → Implement noise control measures. After pressing the  key and releasing the alarm, return the data of the relevant function codes (such as the frequency commands and PID commands (specified through the keypad) or the output frequencies modified by the UP/DOWN terminal commands) back to the original values and then restart the operation.
(3) The control circuit failed.	Check if <i>erf</i> occurs each time the power is turned ON. → The control PCB (on which the CPU is mounted) is defective. Contact your TECO-Westinghouse Motor Company representative.

[27] *E_rH* Hardware error

Problem The LSI on the power printed circuit board malfunctions.

Possible Causes	What to Check and Suggested Measures
(1) The inverter capacity setting on the control printed circuit board is wrong.	It is necessary to set the inverter capacity correctly. → Contact your TECO-Westinghouse Motor Company representative.
(2) Data stored in the power printed circuit board memory is corrupted.	It is necessary to replace the power printed circuit board. → Contact your TECO-Westinghouse Motor Company representative.
(3) The control printed circuit board is misconnected to the power printed circuit board.	It is necessary to replace the power or control printed circuit board. → Contact your TECO-Westinghouse Motor Company representative.

[28] *Err* Speed mismatch or excessive speed deviation

Problem An excessive deviation appears between the speed command and the detected speed.

Possible Causes	What to Check and Suggested Measures
(1) Incorrect setting of function code data.	Check the following function code data; P01* (Motor (No. of poles)), d15 (Feedback encoder pulse count/rev), and d16 and d17 (Feedback pulse correction factor 1 and 2). → Specify data of function codes P01*, d15, d16, and d17 in accordance with the motor and PG.
(2) Overload.	Measure the inverter output current. → Reduce the load. Check whether any mechanical brake is working. → Release the mechanical brake.
(3) The motor speed does not rise due to the current limiter operation.	Check the data of function code F44 (Current limiter (Level)). → Change the F44 data correctly. Or, set the F43 data to "0" (Disable) if the current limiter operation is not needed. Check the data of function codes F04*, F05*, and P01* through P12* to ensure that the V/f pattern setting is right. → Match the V/f pattern setting with the motor ratings. → Change the function code data in accordance with the motor parameters.
(4) Function code settings do not match the motor characteristics.	Check whether the data of P01*, P02*, P03*, P06*, P07*, P08*, P09*, P10* and P12* match the parameters of the motor. → Perform auto-tuning of the inverter, using the function code P04*.
(5) Wrong wiring between the pulse generator (PG) and the inverter.	Check the wiring between the PG and the inverter. → Correct the wiring. Check that the relationships between the PG feedback signal and the run command are as follows: • For the FWD command: the B phase pulse is in the High level at rising edge of the A phase pulse • For the REV command: the B phase pulse is in the Low level at rising edge of the A phase pulse → If the relationship is wrong, interchange the A and B phase wires.
(6) Wiring to the motor is incorrect.	Check the wiring to the motor. → Connect the inverter output terminals U, V, and W to the motor input terminals U, V, and W, respectively.
(7) The motor speed does not rise due to the torque limiter operation.	Check the data of F40 (Torque limiter 1-1). → Correct the F40 data. Or, set the F40 data to "999" (Disable) if the torque limiter operation is not needed.



[29] *ncb* NTC wire break error

Problem A wire break is found in the NTC thermistor detection circuit.

Possible Causes	What to Check and Suggested Measures
(1) The NTC thermistor cable is broken.	Check whether the motor cable is broken. → Replace the motor cable.
(2) The temperature around the motor is extremely low (lower than -30°C (-22°F)).	Measure the temperature around the motor. → Reconsider the use environment of the motor.
(3) The NTC thermistor is broken.	Measure the resistance of the NTC thermistor. → Replace the motor.

[30] *Err* Mock alarm

Problem The LED displays the alarm *err*.

Possible Causes	What to Check and Suggested Measures
(1) The  +  keys were held down for more than 5 seconds.	→ To escape from this alarm state, press the  key.

[31] *L_{oF}* PID feedback wire break

Problem The PID feedback wire is broken.

Possible Causes	What to Check and Suggested Measures
(1) The PID feedback signal wire is broken.	Check whether the PID feedback signal wires are connected correctly. → Check whether the PID feedback signal wires are connected correctly. Or, tighten up the related terminal screws. → Check whether any contact part bites the wire sheath.
(2) PID feedback related circuit affected by strong electrical noise.	Check if appropriate noise control measures have been implemented (e.g., correct grounding and routing of signal wires, communication cables, and main circuit wires). → Implement noise control measures. → Separate the signal wires from the main power wires as far as possible.

[32] *dBH* Braking transistor error

Problem A braking transistor error is detected.

Possible Causes	What to Check and Suggested Measures
(1) The braking transistor is broken.	Check whether resistance of the braking resistor is correct or there is a misconnection of the resistor. → Consult your TECO-Westinghouse Motor Company representative for repair.

[33] *Er_o* Positioning control error (Servo-lock)

Problem An excessive positioning deviation has occurred when the servo-lock function was activated.

Possible Causes	What to Check and Suggested Measures
(1) Insufficient gain in positioning control system.	Readjust the settings of J97 (Servo-lock (Gain)) and d03 (Speed control 1 P (Gain)).
(2) Incorrect control completion width.	Check whether the setting of J99 (Servo-lock (Completion width)) is correct. → Correct the setting of J99.

[34] *Er_o* Positioning control error (Synchronous control)

Problem An excessive positioning deviation has occurred when the synchronous control function was activated.
 For details, refer to the instruction manual of the PG interface card.

Possible Causes	What to Check and Suggested Measures
(1) Insufficient gain in positioning control system.	Readjust the settings of d72 (Synchronous Control Parameters (APR P gain)) and d03 (Speed control 1 P (Gain)).
(2) Incorrect control completion width.	Check whether the setting of d78 (Synchronous Control Parameters (Over-deviation detection width)) is correct. → Correct the setting of d78.

[35] *ELF* Enable circuit failure

Problem The circuit that detects the status of the enable circuit is broken.

Possible Causes	What to Check and Suggested Measures
(1) Circuit related to the Enable circuit affected by strong electrical noise.	Check if appropriate noise control measures have been implemented (e.g., correct grounding and routing of signal wires, communication cables, and main circuit wires). → Implement noise control measures. → Separate the signal wires from the main power wires as far as possible.

 The "Reset alarm" terminal command **RST** cannot reset this alarm *ecf.* If even a power-off reset cannot restore the inverter state, the inverter needs to be repaired.

[36] ECF Enable circuit failure

Problem The circuit that detects the status of the enable circuit is broken.

Possible Causes	What to Check and Suggested Measures
(1) Contact failure of the interface printed circuit board (PCB). (2) Enable circuit logic error	<p>➔ Check that the interface PCB is firmly mounted in place. (Turning the inverter power off and on clears this alarm.)</p> <p>➔ Check that the two output levels of the safety switch or other safety device are not discrepant. (EN1/EN2 = High/High or Low/Low) (Turning the inverter power off and on clears this alarm.)</p>

10.5 If the “Light Alarm” Indication (L -AL) Appears on the LED Monitor

If the inverter detects a minor abnormal state "light alarm," it can continue the current operation without tripping while displaying the "light alarm" indication L -AL on the LED monitor. In addition to the indication L -AL, the inverter displays the "L-ALARM" (blinking) on the LCD monitor and outputs the "light alarm" signal L-ALM to a digital output terminal to alert the peripheral equipment to the occurrence of a light alarm. (To use the L-ALM, it is necessary to assign the signal to any of the digital output terminals by setting any of function codes E20 through E24 and E27 to "98.")

Function codes H81 and H82 specify which alarms should be categorized as "light alarm." The available "light alarm" codes are check-marked in the "Light alarm" object column in Table 10.1.



To display the "light alarm" and escape from the light alarm state, follow the instructions below.

■ Displaying the light alarm

- 1) Press the  key to enter Programming mode.
- 2) Shift to Menu #5 "5: MAINTENANC," scroll to Page 11, and check the "LALM1" (Light alarm (Latest)). The light alarm is displayed in alarm codes. For details about those codes, see Table 10.1 "Abnormal States Detectable ("Alarm" and "Light Alarm" Objects)."

■ Switching the LED monitor from the light alarm to normal display

If it is necessary to return the LED monitor to the normal display state (showing the running status such as reference frequency) before the light alarm is removed (e.g., when it takes a long time to remove the light alarm), follow the steps below.

- 1) Press the  key to return the LED monitor to the light alarm indication (L -AL).
- 2) With L -AL being displayed, press the  key. The LED monitor returns to the normal display state, but the "L-ALARM" on the LCD monitor continues blinking.

■ Releasing the light alarm



- 1) First remove the "LALM1" (Light alarm (Latest)) under Menu #5, in accordance with the troubleshooting procedure. The reference page for the troubleshooting corresponding to each light alarm is shown in "Ref. page" column in Table 10.1.
- 2) To return the LED monitor from the L -AL display to the normal display state (showing the running status such as reference frequency), press the  key in Running mode.

If the light alarm(s) has been successfully removed in step 1) above, the "L-ALARM" blinking on the LCD monitor disappears and the digital output L-ALM also goes OFF. (If any light alarm persists, e.g., detecting a DC fan lock, the "L-ALARM" continues blinking and the L-ALM remains ON.)



10.6 If an Abnormal Pattern Appears on the LED Monitor except Alarm Codes and "Light Alarm" Indication (L -RL)

[1] - - - - (center bar) appears

Problem A center bar (- - - -) appeared on the LED monitor.

Possible Causes	What to Check and Suggested Measures
(1) When PID control had been disabled (J01 = 0), you changed E43 (LED Monitor (Item selection)) to 10 or 12. With the PID being enabled (J01 = 1, 2, or 3), you disabled PID control (J01 = 0) when the LED monitor had been set to display the PID command or PID feedback amount by pressing the  key.	Make sure that when you wish to view other monitor items, E43 is not set to "10: PID command" or "12: PID feedback amount." → Set E43 to a value other than "10" or "12." Make sure that when you wish to view a PID command or a PID feedback amount, J01 (PID control) is not set to "0: Disable." → Set J01 to "1: Enable (Process control normal operation)," "2: Enable (Process control inverse operation)," or "3: Enable (Dancer control)."
(2) The keypad was poorly connected.	Prior to proceed, check that pressing the  key does not change the display on the LED monitor. Check continuity of the extension cable for the keypad used in remote operation. → Replace the cable.

[2] _ _ _ _ (under bar) appears

Problem Although you pressed the  /  key or entered a run forward command **FWD** or a run reverse command **REV**, the motor did not start and an under bar (_ _ _ _) appeared on the LED monitor.

Possible Causes	What to Check and Suggested Measures
(1) The voltage of the DC link bus was low.	Select 5_01 under Menu #5 "Maintenance Information" in Programming mode on the keypad, then check the DC link bus voltage which should be 200 VDC or below for three-phase 230 V series, and 400 VDC or below for three-phase 460 V series. → Connect the inverter to a power supply that meets its input specifications.
(2) The main power is not ON, while the auxiliary input power to the control circuit is supplied.	Check whether the main power is turned ON. → Turn the main power ON.
(3) Although power is supplied not via the commercial power line but via the DC link bus, the main power down detection is enabled (H72 = 1).	Check the connection to the main power and check if the H72 data is set to "1" (factory default). → Correct the H72 data.
(4) Inverter running on single-phase power	→ Refer to Section 10.7 "If the Inverter is Running on Single-Phase Power," [2].

[3] ([]) appears

Problem Parentheses ([]) appeared on the LED monitor during speed monitoring on the keypad.

Possible Causes	What to Check and Suggested Measures
(1) The display data overflows the LED monitor.	Check whether the output frequency multiplied by the display coefficient (E50) is 1,000,000 or more. → Correct the E50 data.

10.7 If the Inverter is Running on Single-Phase Power

[1] The AC fan(s) does not work. (230 V series with 60 HP or above or 460 V series with 125 HP or above)

Possible Causes	Suggested Measures
The power supply is connected to the main circuit power input terminal L2.	Connect the power supply to L1 and L3.

[2] (under bar) appears

Possible Causes	Suggested Measures
The power supply is connected to the main circuit power input terminal L2 and the main power down detection is activated.	Connect the power supply to L1 and L3.

[3] The motor does not run as expected.

Possible Causes	Suggested Measures
Large voltage ripple inside the inverter due to single-phase power	When the inverter runs on single-phase power, the voltage ripple becomes larger than that on three-phase power so that an operation error span becomes wider, causing lower performance than expected. To improve the accuracy in operation, use the inverter on three-phase power.

[4] *PbF* Charger circuit fault (230 V series with 60 HP or above or 460 V series with 125 HP or above)

Possible Causes	Suggested Measures
The power supply is connected to the main circuit power input terminal L2.	Connect the power supply to L1 and L3.

[5] *L in* Input phase loss

Possible Causes	Suggested Measures
The input phase loss protection is activated.	Disable the input phase loss protection by switching Bit 1 of H98 to "0." When switching from the factory default of H98, modify the H98 data from 82 to 81 in decimal.

[6] *DH1* Heat sink overheat, *DH3* Inverter internal overheat, or *DLU* Inverter overload

Possible Causes	Suggested Measures
The inverter was running with load exceeding the single-phase rating.	To run the inverter on single-phase power, it is necessary to derate the output to the lower level than that on three-phase power. Review the load conditions to run the inverter within the single-phase rating, or increase the inverter capacity.

Chapter 11 Specifications

11.1 Drive Ratings

11.1.1 230 V series

CT mode designed for constant torque load applications

Item		Specifications																			
Model EQ7-2XXX-C		0P5	001	002	003	005	007	010	015	020	025	030	040	050	060	075	100	125	150		
Nominal applied motor ^{*1} for three phase input [HP]		1/2	1	2	3	5	7.5	7.5	10	15	20	25	30	40	50	60	75	100	125		
Nominal applied motor ^{*1} for single phase input [HP]		1/4	1/2	1	1.5	3	3	3	5	7.5	10	10	15	20	25	30	30	40	40		
Output ratings	Three phase input	Rated capacity *2 [kVA]	1.2	2.0	3.2	4.4	7.2	11	11	15	20	25	30	36	47	58	72	86	113	138	
		Rated current [A]	3	5	8	11	18	27	27	37	49	63	76	90	119	146	180	215	283	346	
	Single phase input	Rated capacity *2 [kVA]	0.8	1.3	1.9	2.6	4.4	6.8	6.8	9.2	10	13	15	18	24	30	37	38	44	52	
		Rated current [A]	1.9	3.1	4.7	6.3	11	17	17	23	26	33	38	45	61	75	93	95	109	131	
Rated voltage ^{*3} [V]		Three-phase, 200 to 240 V (with AVR function)												Three-phase 200 to 230 V (with AVR function)							
Overload capability		150% -1 min, 200% -3.0 s																			
Input ratings	Three phase input	Voltage, frequency	Three-phase, 200 to 240 V, 50/60 Hz												Three-phase, 200 to 220 V, 50 Hz				Three-phase, 200 to 230 V, 60 Hz		
		Voltage, frequency variations	Voltage: +10 to -15% (Interphase voltage unbalance: 2% or less), ^{*4} Frequency: +5 to -5%																		
		Input current with DCR	1.5	3	5.5	7.7	13	18.5	18.5	25.1	37.6	50.2	62.7	75.3	100	120	145	178	246	291	
		Input current without DCR	2.8	4.7	8.5	11.9	20	28.4	28.4	38.6	54.8	72.4	87.7	101	136	167	203	-			
		Required capacity with DCR ^{*5} [kVA]	0.6	1.2	2.2	3.1	5.2	7.4	7.4	10	15	20	25	30	40	48	58	71	98	116	
	Single phase input	Voltage, frequency	Single-phase, 200 to 240 V, 50/60Hz												Single-phase, 200 to 220 V, 50 Hz				Single-phase, 200 to 230 V, 60 Hz		
		Voltage, frequency variations	Voltage: +10 to -10% , Frequency: +5 to -5%																		
		Input current with DCR	2.0	3.5	6.6	9.5	17.2	25.1	25.1	33.1	41.8	56.1	67.7	79	114	143	172	181	218	252	
		Input current without DCR	3.1	5.3	9.5	13.2	22.2	31.5	31.5	42.7	60.7	80.1	97	112	151	185	225	228	-		
		Required capacity with DCR ^{*5} [kVA]	0.5	0.9	1.6	2.2	4.0	5.8	5.8	7.7	9.7	13	16	18	26	33	40	42	50	58	
Braking	Torque ^{*6} [%]	150%			100%					20%					10 to 15%						
	Braking transistor	Built-in																			
	Built-in braking resistor	Built-in																			
	Braking time [s]	5 s																			
%ED	5			3			5			3			2			3			2		
DC reactor (DCR)	Option															As standard *7					
Keypad	Multi-function keypad																				
Applicable safety standards	UL508C, C22.2No.14, EN61800-5-1:2007,EN61800-5-2:2007 SIL2, EN ISO13849-1:2008 PL=d Cat.3,EN954-1:1996 Cat.3																				
Enclosure (IEC60529)	IP20, UL open type , NEMA1(Option)												IP00, UL open type , NEMA1(Option)								
Cooling method	Natural cooling						Fan cooling														
Weight/Mass [lbs(kg)]	3.8 (1.7)	4.4 (2.0)	6.2 (2.8)	6.6 (3.0)	6.6 (3.0)	14.3 (6.5)	14.3 (6.5)	14.3 (6.5)	12.8 (5.8)	20.9 (9.5)	20.9 (9.5)	22 (10)	55.1 (25)	70.6 (32)	92.6 (42)	94.8 (43)	137 (62)	231 (105)			

(*1) 4-pole standard motor

(*2) Rated capacity is calculated by assuming the output rated voltage as 230 V for 230 V series and 460 V for 460 V series.

(*3) Output voltage cannot exceed the power supply voltage. At single-phase input use, the output voltage may be lower than three-phase input.

(*4) Voltage unbalance [%] = (Max. voltage [V] - Min. voltage [V])/Three-phase average voltage [V]*67(See IEC61800-3.) If this value is 2 to 3%, use an optional AC reactor (ACR).

(*5) Required when a DC reactor (DCR) is used.

(*6) Without external braking resistor condition. Average braking torque for the motor running alone. (It varies with the efficiency of the motor.)

(*7) For Inverters of 100HP or above , the DC reactor is provided as separate standard component. Be sure to connect it to those inverters.

VT mode designed for variable torque load applications

Item		Specifications																			
Model EQ7-2XXX-C		0P5	001	002	003	005	007	010	015	020	025	030	040	050	060	075	100	125	150		
Nominal applied motor ^{*1} for three phase input [HP]		1/2	1	2	3	5	7.5	10	15	20	25	30	40	50	60	75	100	125	150		
Nominal applied motor ^{*1} for single phase input [HP]		1/4	1/2	1	1.5	3	3	5	7.5	10	10	15	20	25	30	30	30	40	50		
Output ratings	Three phase input	Rated capacity ^{*2} [kVA]	1.2	2.0	3.2	4.4	7.2	11	13	18	24	30	35	46	58	72	86	113	138	165	
		Rated current ^{*4} [A]	3	5	8	11	18	27	31.8 (29)	46.2 (42)	59.4 (55)	74.8 (68)	88 (80)	115 (107)	146	180	215	283	346	415	
	Single phase input	Rated capacity ^{*2} [kVA]	0.8	1.3	1.9	2.6	4.4	6.8	9.2	12	13	16	18	23	30	37	38	41	52	59	
		Rated current [A]	1.9	3.1	4.7	6.3	11	17	23	30	32	39	44	58	74	93	95	102	131	149	
	Rated voltage ^{*3} [V]		Three-phase, 200 to 240 V (with AVR function)												Three-phase 200 to 230 V (with AVR function)						
	Overload capability		150% -1 min, 200% -3.0 s						120% -1 min												
Input ratings	Three phase input	Voltage, frequency	Three-phase, 200 to 240 V, 50/60 Hz												Three-phase, 200 to 220 V, 50 Hz					Three-phase, 200 to 230 V, 60 Hz	
		Voltage, frequency variations	Voltage: +10 to -15% (Interphase voltage unbalance: 2% or less), ^{*5} Frequency: +5 to -5%																		
		Input current with DCR	1.5	3	5.5	7.7	13	18.5	25.1	37.6	50.2	62.7	75.3	100	120	145	178	246	291	358	
		Input current without DCR	2.8	4.7	8.5	11.9	20	28.4	38.6	54.8	72.4	87.7	101	136	167	203	244	-			
		Required capacity with DCR ^{*6} [kVA]	0.6	1.2	2.2	3.1	5.2	7.4	10.0	15.0	20.0	25.0	30.0	40.0	48.0	58.0	71.0	98.0	116	143	
	Single phase input	Voltage, frequency	Single-phase, 200 to 240 V, 50/60 Hz												Single-phase, 200 to 220 V, 50 Hz					Single-phase, 200 to 230 V, 60 Hz	
		Voltage, frequency variations	Voltage: +10 to -10% , Frequency: +5 to -5%																		
		Input current with DCR	2.0	3.5	6.6	9.5	17.2	25.1	34.0	47.0	55.1	67.9	78.1	107	140	173	179	202	258	293	
		Input current without DCR	3.1	5.3	9.5	13.2	22.2	31.5	42.7	60.7	80.1	97	112	151	185	225	233	-			
		Required capacity with DCR ^{*6} [kVA]	0.5	0.9	1.6	2.2	4.0	5.8	7.9	11	13	16	18	25	32	40	41	47	59	67	
Braking	Torque ^{*7} [%]	150%			100%			70%			15%			7 to 12%							
	Braking transistor	Built-in															-		-		
	Built-in braking resistor	Built-in																			
	Braking time [s]	5 s					3.7 s		3.7 s		3.4 s		-								
%ED	5	3	5	3	2	2.2	2.2	1.4	-												
DC reactor (DCR)	Option															As standard ^{*8}					
Keypad	Multi-function keypad as standard																				
Applicable safety standards	UL508C, C22.2No.14, EN61800-5-1:2007,EN61800-5-2:2007 SIL2, EN ISO13849-1:2008 PL=d Cat 3,EN954-1:1996 Cat.3																				
Enclosure (IEC60529)	IP20, UL open type , NEMA1(Optional)												IP00, UL open type , NEMA1(Optional)								
Cooling method	Natural cooling						Fan cooling														
Weight/Mass [lbs(kg)]	3.8 (1.7)	4.4 (2.0)	6.2 (2.8)	6.6 (3.0)	6.6 (3.0)	14.3 (6.5)	14.3 (6.5)	14.3 (6.5)	12.8 (5.8)	20.9 (9.5)	20.9 (9.5)	22 (10)	55.1 (25)	70.6 (32)	92.6 (42)	94.8 (43)	137 (62)	231 (105)			

(*1) 4-pole standard motor

(*2) Rated capacity is calculated by assuming the output rated voltage as 230 V for 230 V series and 460 V for 460 V series.

(*3) Output voltage cannot exceed the power supply voltage. At single-phase input use, the output voltage may be lower than three-phase input.

(*4) To use the inverter with the carrier frequency of 3 kHz or more at the surrounding temperature of 40°C(104°F) or higher, manage the load so that the current comes to be within the rated ones enclosed in parentheses () in continuous running.

(*5) Voltage unbalance [%] = (Max. voltage [V] - Min. voltage [V])/Three-phase average voltage [V] *67(See IEC61800-3.) If this value is 2 to 3%, use an optional AC reactor (ACR).

(*6) Required when a DC reactor (DCR) is used.

(*7) Without external braking resistor condition. Average braking torque for the motor running alone. (It varies with the efficiency of the motor.)

(*8) For inverters of 100HP or above, the DC reactor is provided as separate standard component. Be sure to connect it to those inverters.

11.1.2 460 V series

CT mode designed for constant torque load applications

Item		Specifications																			
Model EQ7-4XXX-C		0P5	001	002	003	005	007	010	015	020	025	030	040	050	060	075	100	-	-		
Nominal applied motor ^{*1} for three phase input [HP]		1/2	1	2	3	5	7.5	7.5	10	15	20	25	30	40	50	60	75	-	-		
Nominal applied motor ^{*1} for single phase input [HP]		1/4	1/2	1	1.5	3	3	3	5	7.5	10	10	15	20	25	30	30	-	-		
Output ratings	Three phase input	Rated capacity *2 [kVA]		1.2	2.0	3.2	4.4	7.2	11	11	15	20	25	31	36	48	60	73	89	-	-
		Rated current [A]		1.5	2.5	4	5.5	9	13.5	13.5	18.5	24.5	32	39	45	60	75	91	112	-	-
	Single phase input	Rated capacity *2 [kVA]		0.8	1.2	2.0	2.4	4.5	6.4	6.4	9.6	10	14	16	18	24	30	36	44	-	-
		Rated current [A]		0.9	1.5	2.4	3.0	5.6	8.0	8.0	12	13	17	20	23	30	38	45	55	-	-
Rated voltage ^{*3} [V]		Three-phase, 380 to 480 V (with AVR function)																			
Overload capability		150% -1 min, 200% -3.0 s																			
Input ratings	Three phase input	Voltage, frequency		Three-phase, 380 to 480 V, 50/60 Hz																	
		Voltage, frequency variations		Voltage: +10 to -15% (Interphase voltage unbalance: 2% or less), ^{*4} Frequency: +5 to -5%																	
		Input current with DCR		0.7	1.5	2.6	4	6.6	9.2	9.2	12.4	18.8	25	31	36	50	60	72	89	-	-
		Input current without DCR		1.4	2.6	5.1	7.1	11.3	15	15	20.1	28.6	38	45.4	52.6	67.7	82	99.1	-	-	-
		Required capacity with DCR ^{*5} [kVA]		0.6	1.2	2.1	3.2	5.3	7.4	7.4	9.9	15.0	20.0	25.0	29.0	40.0	48.0	58.0	71.0	-	-
	Single phase input	Voltage, frequency		Single-phase, 380 to 480 V, 50/60 Hz																	
		Voltage, frequency variations		Voltage: +10 to -10% , Frequency: +5 to -5%																	
		Input current with DCR		1.0	1.8	3.5	4.7	8.5	11.7	11.7	16.8	21.5	29	34.5	41.6	57.1	69.7	84.5	106	-	-
		Input current without DCR		1.7	3.1	5.9	8.2	13.0	17.3	17.3	23.2	33	43.8	52.3	60.6	77.9	94.3	114	140	-	-
		Required capacity with DCR ^{*5} [kVA]		0.5	0.9	1.7	2.2	4.0	5.4	5.4	7.8	9.9	13	16	19	26	32	39	49	-	-
Braking	Torque ^{*6} [%]		150%			100%					20%				10 to 15%				-	-	
	Braking transistor		Built-in																		
	Built-in braking resistor		Built-in																		
	Braking time [s]		5 s																		
%ED		5	3	5	3	2	3	3	2											-	-
DC reactor (DCR)		Option															As standard *7				
Keypad		Multi-function keypad as standard																			
Applicable safety standards		UL508C, C22.2No.14, EN61800-5-1:2007,EN61800-5-2:2007 SIL2, EN ISO13849-1:2008 PL=d Cat.3,EN954-1:1996 Cat.3																			
Enclosure (IEC60529)		IP20, UL open type , NEMA1(OPTION)											IP00 UL open type , NEMA1(OPTION)								
Cooling method		Natural cooling						Fan cooling													
Weight/Mass [lbs(kg)]		3.8 (1.7)	4.4 (2.0)	5.7 (2.6)	6.0 (2.7)	6.6 (3.0)	14.3 (6.5)	14.3 (6.5)	14.3 (6.5)	12.8 (5.8)	20.9 (9.5)	20.9 (9.5)	22 (10)	55.1 (25)	57.3 (26)	68.3 (31)	72.8 (33)	-	-		

(*1) 4-pole standard motor

(*2) Rated capacity is calculated by assuming the output rated voltage as 230 V for 230 V series and 460 V for 460 V series.

(*3) Output voltage cannot exceed the power supply voltage. At single-phase input use, the output voltage may be lower than three-phase input.

(*4) Voltage unbalance [%] = (Max. voltage [V] - Min. voltage [V])/Three-phase average voltage [V] *67(See IEC61800-3.) If this value is 2 to 3%, use an optional AC reactor (ACR).

(*5) Required when a DC reactor (DCR) is used.

(*6) Without external braking resistor condition. Average braking torque for the motor running alone. (t varies with the efficiency of the motor.)

(*7) For inverters of 100HP or above, the DC reactor is provided as separate standard component. Be sure to connect it to those inverters.

CT mode designed for constant torque load applications

Item		Specifications															
Model EQ7-4XXX-C		125	150	200	250	300	350	450	500	600	700	800	900	1000	-	-	
Nominal applied motor ^{*1} for three phase input [HP]		100	125	150	200	250	300	350	400	450	500	600	800	900	-	-	
Nominal applied motor ^{*1} for single phase input [HP]		40	50	60	60	75	100	100	125	150	150	200	250	300	-	-	
Output ratings	Three phase input	Rated capacity ^{*2} [kVA]	120	140	167	202	242	300	330	414	466	518	590	765	932	-	-
		Rated current [A]	150	176	210	253	304	377	415	520	585	650	740	960	1170	-	-
	Single phase input	Rated capacity ^{*2} [kVA]	48	57	68	82	97	118	133	162	184	206	236	305	373	-	-
		Rated current [A]	61	72	86	103	122	149	167	204	231	259	297	384	469	-	-
	Rated voltage ^{*3} [V]		Three-phase, 380 to 480 V (with AVR function)														
	Overload capability		150%-1 min, 200% -3.0 s														
Input ratings	Three phase input	Voltage, frequency	Three-phase, 380 to 440 V, 50 Hz Three-phase, 380 to 480 V, 60 Hz														
		Voltage, frequency variations	Voltage: +10 to -15% (Interphase voltage unbalance: 2% or less) ^{*4} , Frequency: +5 to -5%														
	Input current with DCR	120	143	176	207	250	311	340	436	487	547	614	767	970	-	-	
	Required capacity with DCR ^{*5} [kVA]	96	114	140	165	199	248	271	347	388	436	489	611	773	-	-	
	Single phase input	Voltage, frequency	Single-phase, 380 to 440 V, 50 Hz Single-phase, 380 to 480 V, 60 Hz														
		Voltage, frequency variations	Voltage: +10 to -10% , Frequency: +5 to -5%														
		Input current with DCR	113	137	164	192	234	286	319	395	446	512	575	707	892	-	-
		Required capacity with DCR ^{*5} [kVA]	53	63	76	89	108	132	147	182	206	236	265	325	410	-	-
Braking	Torque ^{*6} [%]	10 to 15 %															
	Braking transistor	-															
DC reactor (DCR)		As standard ^{*7}															
Keypad		Multi-function keypad as standard															
Applicable safety standards		UL508C, C22.2No.14, EN61800-5-1:2007,EN61800-5-2:2007 SIL2, EN ISO13849-1:2008 PL=d Cat.3,EN954-1:1996 Cat.3															
Enclosure (IEC60529)		IP00, UL open type , NEMA1(Optional)															
Cooling method		Fan cooling															
Weight/Mass [lbs(kg)]		93 (42)	137 (62)	141 (64)	207 (94)	216 (98)	284 (129)	309 (140)	540 (245)	540 (245)	805 (365)	805 (365)	1170 (530)	1170 (530)	-	-	

(*1) 4-pole standard motor

(*2) Rated capacity is calculated by assuming the output rated voltage as 230 V for 230 V series and 460 V for 460 V series.

(*3) Output voltage cannot exceed the power supply voltage. At single-phase input use, the output voltage may be lower than three-phase input.

(*4) Voltage unbalance [%] = (Max. voltage [V] - Min. voltage [V])/Three-phase average voltage [V]*67(See IEC61800-3.)If this value is 2 to 3%, use an optional AC reactor (ACR).

(*5) Required when a DC reactor (DCR) is used.

(*6) Without external braking resistor condition. Average braking torque for the motor running alone. (t varies with the efficiency of the motor.)

(*7) For inverters of 100HP or above, the DC reactor is provided as separate standard component. Be sure to connect it to those inverters.

VT mode designed for variable torque load applications

Item		Specifications																		
Model EQ7-4XXX-C		0P5	001	002	003	005	007	010	015	020	025	030	040	050	060	075	100	-	-	
Nominal applied motor ^{*1} for three phase input [HP]		1/2	1	2	3	5	7.5	10	15	20	25	30	40	50	60	75	100	-	-	
Nominal applied motor ^{*1} for single phase input [HP]		1/4	1/2	1	1.5	3	3	5	7.5	10	10	15	20	25	30	30	40	-	-	
Output ratings	Three phase input	Rated capacity *2 [kVA]	1.2	2.0	3.2	4.4	7.2	11	13.1	18.3	24	29	36	48	60	73	89	120	-	-
		Rated current [A]	1.5	2.5	4	5.5	9	13.5	16.5	23	30.5	37	45	60	75	91	112	150	-	-
	Single phase input	Rated capacity *2 [kVA]	0.8	1.2	2.0	2.4	4.5	6.4	8.8	12	14	16	18	23	30	37	43	47	-	-
		Rated current [A]	0.9	1.5	2.4	3.0	5.6	8.0	11	15	17	20	23	29	37	46	54	59	-	-
	Rated voltage ^{*3} [V]		Three-phase, 380 to 480 V (with AVR function)																	
	Overload capability		150% -1 min, 200% -3.0 s							120% -1 min										
Input ratings	Three phase input	Voltage, frequency	Three-phase, 380 to 480 V, 50/60 Hz																	
		Voltage, frequency variations	Voltage: +10 to -15% (Interphase voltage unbalance: 2% or less) ^{*4} , Frequency: +5 to -5%																	
		Input current with DCR	0.7	1.5	2.6	4	6.6	9.2	12.5	18.8	25.1	31.3	36.3	50.2	60.2	72.7	89.1	120	-	-
		Input current without DCR	1.4	2.6	5.1	7.1	11.3	15	20.1	28.6	38	45.4	52.6	67.7	82	99.1	121	-	-	-
		Required capacity with DCR ^{*5} [kVA]	0.6	1.2	2.2	3.1	5.2	7.4	10	15	20	25	29	40	48	58	71	96	-	-
	Single phase input	Voltage, frequency	Single-phase, 380 to 480 V, 50/60 Hz																	
		Voltage, frequency variations	Voltage: +10 to -10% , Frequency: +5 to -5%																	
		Input current with DCR	1.0	1.8	3.5	4.7	8.5	11.7	15.7	24	28.6	34.6	40	53.4	69.1	84.3	99.7	110	-	-
		Input current without DCR	1.7	3.1	5.9	8.2	13.0	17.3	23.2	33	43.8	52.3	60.6	77.9	94.3	114	134	-	-	-
		Required capacity with DCR ^{*5} [kVA]	0.5	0.9	1.7	2.2	4.0	5.4	7.3	11	13	16	18	25	32	39	46	51	-	-
Braking	Torque ^{*6} [%]		150%			100%			70%			15%			7 to 12%			-	-	
	Braking transistor		Built-in															-	-	
	Built-in braking resistor		Built-in																	
	Braking time [s]		5 s					3.7s	3.7s	3.4s										
%ED		5	3	5	3	2	2.2	2.2	1.4											
DC reactor (DCR)		Option															As standard *7			
Keypad		Multi-function keypad as standard																		
Applicable safety standards		UL508C, C22.2No.14, EN61800-5-1:2007,EN61800-5-2:2007 SIL2, EN ISO13849-1:2008 PL=d Cat.3,EN954-1:1996 Cat.3																		
Enclosure (IEC60529)		IP20, UL open type , NEMA1(Option)											IP00 UL open type , NEMA1(Option)							
Cooling method		Natural cooling						Fan cooling												
Weight/Mass [lbs(kg)]		3.8 (1.7)	4.4 (2.0)	5.7 (2.6)	6.0 (2.7)	6.6 (3.0)	14.3 (6.5)	14.3 (6.5)	14.3 (6.5)	12.8 (5.8)	20.9 (9.5)	20.9 (9.5)	22 (10)	55.1 (25)	57.3 (26)	68.3 (31)	72.8 (33)	-	-	

(*1) 4-pole standard motor

(*2) Rated capacity is calculated by assuming the output rated voltage as 230 V for 230 V series and 460 V for 460 V series.

(*3) Output voltage cannot exceed the power supply voltage.

(*4) Voltage unbalance [%] = (Max. voltage [V] - Min. voltage [V])/Three-phase average voltage [V] *67(See IEC61800-3.) If this value is 2 to 3%, use an optional AC reactor (ACR).

(*5) Required when a DC reactor (DCR) is used.

(*6) Without external braking resistor condition. Average braking torque obtained by use of a motor. (Varies with the efficiency of the motor.)

(*7) For inverters of 100HP or above, the DC reactor is provided as separate standard component. Be sure to connect it to those inverters.

VT mode designed for variable torque load applications

Item		Specifications															
Model EQ7-4XXX-C		125	150	200	250	300	350	450	500	600	700	800	900	1000	-	-	
Nominal applied motor ^{*1} for three phase input [HP]		125	150	200	250	300	350	450	500	600	700	800	900	1000	-	-	
Nominal applied motor ^{*1} for single phase input [HP]		50	50	60	75	100	100	125	150	200	200	250	300	400	-	-	
Output ratings	Three phase input	Rated capacity *2 [kVA]	140	167	202	242	300	331	414	518	590	669	765	932	1092	-	-
		Rated current [A]	176	210	253	304	377	415	520	650	740	840	960	1170	1370	-	-
	Single phase input	Rated capacity *2 [kVA]	55	65	78	96	116	128	160	198	229	259	305	368	461	-	-
		Rated current [A]	70	82	99	121	146	161	202	250	288	326	384	462	579	-	-
	Rated voltage ^{*3} [V]		Three-phase, 380 to 480 V (with AVR function)														
	Overload capability		120% -1 min														
Input ratings	Three phase input	Voltage, frequency	Three-phase, 380 to 440 V, 50 Hz Three-phase, 380 to 480 V, 60 Hz														
		Voltage, frequency variations	Voltage: +10 to -15% (Interphase voltage unbalance: 2% or less) ^{*4} , Frequency: +5 to -5%														
		Input current with DCR	143	175	207	249	311	340	435	547	613	686	766	970	1093	-	-
		Required capacity with DCR ^{*5} [kVA]	114	140	165	199	248	271	347	436	489	547	611	773	871	-	-
	Single phase input	Voltage, frequency	Single-phase, 380 to 440 V, 50 Hz Single-phase, 380 to 480 V, 60 Hz														
		Voltage, frequency variations	Voltage: +10 to -10% , Frequency: +5 to -5%														
		Input current with DCR	132	158	188	226	283	309	392	492	558	633	717	878	1060	-	-
		Required capacity with DCR ^{*5} [kVA]	61	73	87	105	130	143	181	227	257	291	330	404	488	-	-
Braking	Torque ^{*6} [%]	7 to 12%															
	Braking transistor	-															
DC reactor (DCR)		As standard *7															
Keypad		Multi-function keypad as standard															
Applicable safety standards		UL508C, C22.2No.14, EN61800-5-1:2007,EN61800-5-2:2007 SIL2, EN ISO13849-1:2008 PL=d Cat.3,EN954-1:1996 Cat.3															
Enclosure (IEC60529)		IP00, UL open type , NEMA1(Option)															
Cooling method		Fan cooling															
Weight/Mass [lbs(kg)]		93 (42)	137 (62)	141 (64)	207 (94)	216 (98)	284 (129)	309 (140)	540 (245)	540 (245)	805 (365)	805 (365)	1170 (530)	1170 (530)	-	-	

(*1) 4-pole standard motor

(*2) Rated capacity is calculated by assuming the output rated voltage as 230 V for 230 V series and 460 V for 460 V series.

(*3) Output voltage cannot exceed the power supply voltage.

(*4) Voltage unbalance [%] = (Max. voltage [V] - Min. voltage [V])/Three-phase average voltage [V]×67(See IEC61800-3.) If this value is 2 to 3%, use an optional AC reactor (ACR).

(*5) Required when a DC reactor (DCR) is used.

(*6) Without external braking resistor condition. Average braking torque obtained by use of a motor. (Varies with the efficiency of the motor.)

(*7) For inverters of 100HP or above , the DC reactor is provided as separate standard component. Be sure to connect it to those inverters.

11.2 Common Specifications

Item		Specifications	Remarks	
Output	Setting range	Maximum frequency	<ul style="list-style-type: none"> • 25 to 500 Hz (CT-Vector, V/f control *1,*2) • 25 to 200 Hz (CT-Vector, Vector control w/PG*7) • 25 to 120 Hz (CT-Vector, sensorless vector control *6, Variable Torque and Constant Torque, various controls,*1 to 7) 	
		Base frequency	25 to 500 Hz variable setting (Variable Torque (Model EQ7-x0P5-C or above) and Constant Torque mode : 120Hz)	
		Starting frequency	0.1 to 60.0 Hz variable setting (sensorless vector control*6/ vector control w/PG, 0.0 Hz for *7)	
		Carrier frequency	<ul style="list-style-type: none"> • 0.75 to 16 kHz variable setting (CT-Vector: EQ7-x0P5-C to EQ7-x100-C, Variable Torque:EQ7-x0P5-C to EQ7-x040-C) • 0.75 to 10 kHz variable setting (CT-Vector : EQ7-x125-C to EQ7-x800-C, Variable Torque: EQ7-x050-C to EQ7-x100-C) • 0.75 to 6 kHz variable setting (CT-Vector: EQ7-x900-C to EQ7-x1000-C Variable Torque: EQ7-x125-C to EQ7-x900-C) • 0.75 to 4 kHz variable setting (Variable Torque: EQ7-x1000-C) • 0.75 to 2kHz variable setting (Constant Torque: EQ7-x150-C to EQ7-x800-C) NOTE: Frequency drops automatically to protect the inverter depending on environmental temperature and output current. (This auto drop function can be cancelled.)	
	Output frequency Accuracy (Stability)	<ul style="list-style-type: none"> • Analog setting: $\pm 0.2\%$ of max. frequency (at $25 \pm 10^\circ\text{C}$)*1 • Digital setting: $\pm 0.01\%$ of max. frequency (at -10 to $+50^\circ\text{C}$) 		
	Setting resolution	<ul style="list-style-type: none"> • Analog setting: Analog setting: 1/3000 of max. frequency (1/1500 with V2 input) • Keypad setting: 0.01Hz (99.99Hz or less), 0.1Hz (100.0 to 500Hz) • Link setting: 1/20000 of max. frequency or 0.01 Hz (fixed) 		
Speed control range	Speed control range	<ul style="list-style-type: none"> • Min. speed: Base speed 1:1500 (4P 1r/min to 1500r/min) *7 • Min. speed: Base speed 1:200 (4P 7.5r/min to 1500r/min) *6 • Min. speed: Base speed 1:4 *7 • Min. speed: Base speed 1:2 *6 		
	Speed control accuracy	<ul style="list-style-type: none"> • Analog setting: $\pm 0.2\%$ of max. frequency (at $25 \pm 10^\circ\text{C}$) *7 • Digital setting: $\pm 0.01\%$ of max. frequency (at -10 to $+50^\circ\text{C}$) • Analog setting: $\pm 0.5\%$ or below of base speed (at $25 \pm 10^\circ\text{C}$) *6 • Digital setting: $\pm 0.5\%$ or below of base speed (at -10 to $+50^\circ\text{C}$) 		
	Functional safety	Stop function Response time SIL PFH Category Performance level <ul style="list-style-type: none"> • Safe torque off (STO: acc EN61800-5-2:2007) • 50ms or less (delay time to "Safe torque off" from turning off either terminal [EN1] or [EN2]) • SIL 2 (Safety integrity level) • 1.7×10^{-9} (Probability of a dangerous random hardware failure per hour) • 3 (EN ISO 13849-1:2008) • d (EN ISO 13849-1:2008) 		
Control	Control method	<ul style="list-style-type: none"> • V/f control *1 • Dynamic torque control *2 • Vector control without speed sensor *6 • Vector control with speed sensor (with an optional PG interface card mounted) *7 		
	Voltage/freq. characteristic	230 V series	<ul style="list-style-type: none"> • Base frequency and max. output frequency can be set to 80 to 240V in common. • The AVR control ON/OFF can be selected. *1 • Non-linear V/f setting (3 points): Free voltage (0 to 240V) and frequency (0 to 500Hz) can be set. *1 	
		460 V series	<ul style="list-style-type: none"> • Base frequency and max. output frequency can be set to 160 to 500V in common. • The AVR control ON/OFF can be selected. *1 • Non-linear V/f setting (3 points): Free voltage (0 to 500V) and frequency (0 to 500Hz) can be set. *1 	
	Torque boost	<ul style="list-style-type: none"> • Auto torque boost (for constant torque load) *1 to *2 • Manual torque boost: Desired torque boost (0.0 to 20.0%) can be set. *1 • Select application load with function code F37. (Variable torque load or constant torque load) *1 		
	Starting torque (Constant Torque mode)	<ul style="list-style-type: none"> • EQ7-x040-C or below: 200% or higher, EQ7-x050-C or above: 180% or higher/set frequency: 0.3Hz *6 • EQ7-x040-C or below: 200% or higher, EQ7-x050-C or above: 180% or higher/set frequency: 0.3Hz Base frequency 50Hz, slip compensation and auto torque boost operation *1 to*2 		
	Start/stop operation	Start/stop operation	Keypad <ul style="list-style-type: none"> • Multi-function keypad: Start and stop with FWD, REV, and STOP keys 	
Start/stop operation		External signals (digital inputs): Forward (Reverse) rotation, stop command (capable of 3-wire operation), coast-to-stop command, external alarm, alarm reset, etc.		
Start/stop operation		Link operation: Operation through RS-485 or field bus (option) communications.		
Start/stop operation		Switching operation command: Remote/Local switching, link switching		

Item	Specifications	Remarks
Enable input(Safe Torque Off (STO))	<ul style="list-style-type: none"> Turning off the circuit between terminals [EN1] and [PLC] or terminals [EN2] and [PLC] stops the inverter's output transistor. (Safe Torque Off: STO) 	
Frequency setting	<ul style="list-style-type: none"> Keypad: Can be set with UP and DOWN keys External Volume: Can be Set with external potentiometer (1 to 5kΩ 1/2W) Analog input: <ul style="list-style-type: none"> 0 to ±10 VDC (±5 VDC)/0 to ±100% (Terminals [12] and [V2]) 0 to +10 VDC (+5 VDC)/0 to +100% (Terminals [12] and [V2]) +4 to +20 mA DC/0 to 100% (Terminal [C1]) 0 to +20 mA DC/0 to 100% (Terminal [C1]) UP/DOWN operation: Frequency can be increased or decreased while the digital input signal is ON. Multi-frequency : Selectable from 16 steps (step 0 to 15) Digital signal: 16bit parallel (binary, BCD) Link operation: Frequency can be set through RS-485 (Standard setting) Switching frequency setting: Frequency setting can be switched (2 settings) with external signal (digital input). <p>Remote/local switching, link switching</p> <ul style="list-style-type: none"> Auxiliary frequency setting: Terminal [12], [C1], or [V2] input can be selected respectively as an additional input. Operation at a specified ratio: The ratio can be set by analog input signal. Inverse operation: <ul style="list-style-type: none"> The setting "0 to +10V DC/0 to 100%" can be switched to "+10 to 0V DC/0 to 100%" by external command. The setting "4 to +20mA DC/0 to 100%" can be switched to "+2 The setting "4 to +20mA DC/0 to 100%" or "0 to +20mA DC/0 to 100% (Terminal [C1])" can be switched to "+20 to 4mA DC/0 to 100%" or "+20 to 0mA DC/0 to 100% (Terminal [C1])" Pulse train input : Pulse input = X7 terminal, rotational direction = general terminal Complementary output: Max. 100kHz, Open collector output: Max. 30kHz 	"DC +1 to +5V" can be adjusted with bias and analog input gain
Acceleration/deceleration time	<ul style="list-style-type: none"> Setting range: From 0.00 to 6000 s Switch: The four types of accel./decel. time can be set or selected individually (switchable during operation). Acceleration/deceleration pattern: Linear accel./decel., S-shape accel./decel. (weak, free, (strong)), curvilinear accel./decel. (accel./decel. max. capacity of constant output) Deceleration mode (coast-to-stop): Coast-to-stop at the operation command OFF. Forcible stop decel.time: Deceleration stop by the forcible stop (STOP) 	
Frequency limiter (Upper limit and lower limit frequencies)	<ul style="list-style-type: none"> Both upper and lower limit frequencies can be variably set in hertz. It is possible to choose the operation done when the set frequency drops below the lower limit from between continuous operation at lower limit frequency and operation stop. 	
Bias frequency	<ul style="list-style-type: none"> Bias of set reference frequency and P D command can be independently set (setting range: 0 to ±100%). 	
Analog input	<ul style="list-style-type: none"> Gain: Setting in the range from 0 to 200% Off-set: Setting in the range from -5.0 to +5.0% Filter: Setting in the range from 0.00s to 5.00s 	
Jump frequency	<ul style="list-style-type: none"> Actuation points (3 points) and their common jump widths (0 to 30.0Hz) can be set. 	
Jogging operation	<ul style="list-style-type: none"> Operation with FWD, or REV key (multifunction keypad) , or digital contact input ,FWD, or REV (Exclusive accel./decel time setting, exclusive frequency setting) 	
Auto-restart after momentary power failure	<ul style="list-style-type: none"> Trip at power failure: The inverter trips immediately after power failure. Trip at power recovery: Coast-to-stop at power failure and trip at power recovery Deceleration stop: Deceleration stop at power failure, and trip after stoppage Continuous operation: Operation is continued using the load inertia energy. Start at the frequency selected before momentary stop: Coast-to-stop at power failure and start after power recovery at the frequency selected before momentary stop. *1 to *3 Start at starting frequency: Coast-to-stop at power failure and start at the starting frequency after power recovery. *1 to *2 	
Current limit by hardware	<ul style="list-style-type: none"> Limiting the current by hardware to prevent overcurrent trip due to sharp load change or momentary power failure which cannot be controlled by software current limit (This function can be cancelled.) 	
Operation by commercial power supply	<ul style="list-style-type: none"> With commercial power selection command, the inverter outputs 50/60Hz (SW50, SW60) . *1 to *2 The inverter has the commercial power supply selection sequence. 	
Slip compensation	<ul style="list-style-type: none"> Compensates for decrease in speed according to the load. *1 to *2 	
Droop control	<ul style="list-style-type: none"> Decrease the speed according to the load torque. 	
Torque limiter	<ul style="list-style-type: none"> Switchable between 1st or 2nd torque limit values Torque limit, torque current limit, and power limit are set for each quadrant. *6, *7 Analog torque limit input 	
Current control (software current limit)	<ul style="list-style-type: none"> Automatically reduces the frequency so that the output current becomes lower than the preset operation level. *1 to *2 	

Item		Specifications	Remarks
Control	P D control	<ul style="list-style-type: none"> • PID adjuster for process control and that for dancer control • Switchable between forward and reverse operations • Low liquid level stop function (pressurized operation possible before low liquid level stop) • PID command: Keypad, analog input (from terminals [12], C1, V2), RS-485 communications • PID feedback value: Analog input (from terminals [12], C1, V2) • Alarm output (absolute value alarm, deviation alarm) • PID output limiter • Integration reset/ho 	
	Auto search for idling motor speed	<ul style="list-style-type: none"> • Estimates the speed of the motor running under no load and starts the motor without stopping it. (Motor electric constant needs tuning: Offline tuning) *1 to *2 and *6 	
	Automatic deceleration	<ul style="list-style-type: none"> • If the DC link bus voltage or calculated torque exceeds the automatic deceleration level during deceleration, the inverter automatically prolongs the deceleration time to avoid overvoltage trip. (t is possible to select forcible deceleration actuated wh • If the calculated torque exceeds automatic deceleration level during constant speed operation, the inverter avoids overvoltage trip by increasing the frequency. 	
	Deceleration characteristic (improving braking ability)	<ul style="list-style-type: none"> • The motor loss is increased during decel. to reduce the regenerative energy in the inverter to avoid overvoltage trip. *1 	
	Automatic energy saving operation	<ul style="list-style-type: none"> • The output voltage is controlled to minimize the total sum of the motor loss and inverter loss at a constant speed. 	
	Overload prevention control	<ul style="list-style-type: none"> • If the ambient temperature or IGBT joint temperature increases due to overload, the inverter lowers the output frequency to avoid overload. 	
	Off-line tuning	<ul style="list-style-type: none"> • Rotary type and non-rotary type are available for tuning the motor constant. 	
	On-line tuning	<ul style="list-style-type: none"> • Performs tuning while the motor is rotating in order to cover the motor speed fluctuation caused by the temperature rise of the motor. 	
	Cooling fan ON/OFF control	<ul style="list-style-type: none"> • Detects inverter internal temperature of the inverter and stops the cooling fan when the temperature is low. • The fan control signal can be output to an external device. 	
	Setting 2nd motor	<ul style="list-style-type: none"> • Switchable among the two motors • Code data for four kinds of specific functions can be switched (even during operation) . t is possible to set the base frequency, rated current, torque boost, and electronic thermal slip compensation as the data for 1st to 2nd motors. 	
	Universal DI	<ul style="list-style-type: none"> • The status of external digital signal connected with the universal digital input terminal is transferred to the host controller. 	
	Universal DO	<ul style="list-style-type: none"> • Digital command signal from the host controller is output to the universal digital output terminal. 	
	Universal AO	<ul style="list-style-type: none"> • The analog command signal from the host controller is output to the analog output terminal. 	
	Speed control	<ul style="list-style-type: none"> • Notch filter for vibration control, *7 	
	Synchronous operation	<ul style="list-style-type: none"> • Synchronous control drives two or more shafts of a conveyer while keeping their positions in synchronization. *7 	
	Preliminary excitation	<ul style="list-style-type: none"> • Excitation is carried out to create the motor flux before starting the motor. *6 and*7 	
	Zero speed control	<ul style="list-style-type: none"> • The motor speed is held to zero by forcibly zeroing the speed command. *7 	
	Servo lock	<ul style="list-style-type: none"> • Stops the inverter and holds the motor in stop position. *7 	
	Torque control *6, *7	<ul style="list-style-type: none"> • Analog torque command input • Speed limit function is provided to prevent the motor from becoming out of control. 	
	Rotation direction control	<ul style="list-style-type: none"> • Preventing reverse rotation • Preventing forward rotation 	
Preventing condensation in motor	<ul style="list-style-type: none"> • When the inverter is stopped, current is automatically supplied to the motor to keep the motor warm and avoid condensation. 		
Battery Operation	<ul style="list-style-type: none"> • The battery operation enables the undervoltage inverter to run the elevator with a battery for moving the cage to the nearest floor. 		
Display	Run/stop	Speed monitor (set frequency, output frequency, motor speed, load shaft speed, line speed, and speed indication with percent) Output current [A], output voltage [V], calculated torque, input power [HP], PID reference value, P D feedback value, P D output	
	Inverter life warning	<ul style="list-style-type: none"> • Life judgment of the main circuit capacitor, electrolytic capacitor on printed circuit board, and cooling fan • Life warning information can be output to an external device. • Ambient temperature: 40 C, Load rate: inverter rated current 100% (LD type: 80%) 	
	Cumulative running hours	<ul style="list-style-type: none"> • Displays the inverter cumulative running hours, integrated power, cumulative motor running hours, and the number of operation start times (of each motor). • Outputs the warning when the maintenance time or the number of start times has exceeded the preset 	
	Trip mode	<ul style="list-style-type: none"> • Displays the cause of trip. 	
	Light-alarm	<ul style="list-style-type: none"> • Shows the light-alarm display [L-AL]. 	
	Running or trip mode	<ul style="list-style-type: none"> • Trip history: Saves and displays the cause of the last four trips (with a code). • Also saves and displays the detailed data recorded on occurrence of the last four trips. 	

Item		Specifications	Remarks	
Protective function	Overcurrent protection	• The inverter is stopped for protection against overcurrent.		
	Short-circuit protection	• The inverter is stopped for protection against overcurrent caused by a short circuit in the output circuit.	OC 1 OC 2 OC 3	
	Ground fault protection	• The inverter is stopped for protection against overcurrent caused by a grounding fault in the output circuit. (EQ7-x040-C or below).		
		• Detecting zero-phase current of output current, the inverter is stopped for protection against overcurrent caused by a grounding fault in the output circuit. (EQ7-x050-C or above)	EF	
	Overvoltage protection	• An excessive voltage (230V series: 400V DC, 460V series: 800V DC) in the DC link circuit is detected and the inverter is stopped. If an excessive voltage is applied by mistake, the protection can not be guaranteed.	OU 1 OU 2 OU 3	
	Undervoltage protection	• The voltage drop (230V series: 200V DC, 460V series: 400V DC) in the DC link circuit is detected to stop the inverter.	LU	
	Input phase loss protection	• The input phase loss is detected to shut off the inverter output. This function protects the inverter. • When the load to be connected is small or DC REACTOR is connected a phase loss is not detected.	L in	
	Output phase loss detection	Detects breaks in inverter output wiring at the start of running and during running, stopping the inverter output.	OP L	
	Overheat protection	• Stop the inverter output detecting excess cooling fan temperature in case of a cooling fan fault or overload.	OH 1	
		• Stop the inverter output detecting a fault of inner agitating fan. (EQ7-2075-C, EQ7-4125-C or above)	OH 3	
		• Stop the inverter output detecting inner temperature of the inverter unit for a cooling fan fault or overload.	OH 3	
	Overload protection	• Protect the braking resistor from over heat by setting the braking resistor electronic thermal function.	dbH	
	Overload protection	• Stop the inverter output detecting a cooling unit temperature of the inverter cooling fan and a switching element temperature calculated with the output current.	OL U	
	External alarm input	• With the digital input signal (THR) opened, the inverter is stopped with an alarm.	OH 2	
	Fuse breaking	• Stop the inverter output detecting the fuse breaking of the main circuit in the inverter. (EQ7-2125-C, EQ7-4150-C or above)	FUS	
	Charging circuit abnormality	• Stop the inverter output detecting the charge circuit abnormality in the inverter. (EQ7-2060-C, EQ7-4125-C or above)	PbF	
	Brake transistor abnormality	• Stop the inverter detecting the brake transistor abnormality. (DB transistor built-in type only)	dbR	
	Over-speed protection *6 to *7	• Stop the inverter when the detected speed exceeds (max. output frequency) × (d32 data or d33 data) × 120% in the case of d35 = 999 *6~*7	OS	
		• Stop the inverter when the detected speed exceeds (max. output frequency) × (d35 data) in the case of d35#999 *6		
		• Stop the inverter when the detected speed exceeds 120Hz × 120% *6		
		• Stop the inverter when the detected speed exceeds 200Hz × 120% *7		
	PG breakwire *7	• Stop the inverter detecting the PG breaking.	PG	
	Motor protection	Electronic thermal	• The inverter is stopped with an electronic thermal function set to protect the motor. Protects the general-purpose motor inverter over all frequency range. (The running level and thermal time constant (0.5 to 75.0 min) can be set.)	OL 1 to OL 4
		PTC thermistor	• A PTC thermistor input stops the inverter to protect the motor. Connect a PTC thermistor between terminal V2 and 11 and set the switch on control print board and the function code.	OH 4
		NTC thermistor	• The NTC thermistor detects a motor temperature. Connect a NTC thermistor between terminal V2 and 11 and set the switch on control print board and the function code.	
		NTC thermistor broken	• Stop the inverter output detecting the built-in motor NTC breaking.	nr b
		Overload early warning	• Warning signal (OL) is output at the predetermined level before stopping the inverter with electronic thermal function.	-
	Memory error	• Data is checked upon power-on and data writing to detect any fault in the memory and to stop the inverter if any.	Er 1	
Keypad communications error detection	• The keypad is used to detect a communication fault between the keypad and inverter main body during operation and to stop the inverter.	Er 2		
CPU error	• Stop the invert detecting a CPU error or LSI error caused by noise.	Er 3		
Option communications error	• When each option is used, a fault of communication with the inverter main body is detected to stop the inverter.	Er 4		
Option error	• When each option is used, the option detects a fault to stop the inverter.	Er 5		
Operation error	• STOP key priority Pressing the STOP key on the keypad or entering the digital input signal will forcibly decelerate and stop the motor even if the operation command through signal input or communication is selected. Er6 will be displayed after the stop. • Start check: If the running command is being ordered when switching the running command method from power-on, alarm reset, or the linked operation, the operation starts suddenly. This function bans running and displays Er6.	Er 6		
Tuning error	• Stop the inverter output when tuning failure, interruption, or any fault as a result of tuning is detected during tuning for motor constant.	Er 7		
RS-485 communications error (port1)	• When the connection port of the keypad connected via RS485 communication port to detect a communication error, The inverter is stopped and displays an error.	Er 8		
Speed deviation excess *6 to *7	• Stop the inverter output when the speed deviation exceeds the specified value (difference between speed command and feedback).	Er E		
Data save error upon undervoltage	• When the undervoltage protection function works, an alarm is displayed if the data is not properly saved.	Er F		
Positioning Control Error	• Stop the inverter output when an excessive positioning deviation has occurred. *7	Er o		
RS-485 communications error (port2)	• Stop the inverter output detecting the communication error between the inverter main unit and a mate when the RS-485 connection port of the touch panel is used to configure the network.	Er P		
Hardware error	• Stop the inverter output detecting the communication error between the inverter main unit and a mate when the RS-485 connection port of the touch panel is used to configure the network..	Er H		
Simulation error	• Simulated alarm is output by the keypad operation.	Er r		
EN Circuit Error	• The circuit to detect EN terminal status is broken (Single fault) *8	Er C		

Item		Specifications	Remarks
Protective function	P D feedback breaking detection	• Stop the inverter output detecting a breaking when the input current is allocated to the PID control feedback. (Select valid/invalid.)	L - αF
	Alarm relay output (for any fault)	• The inverter outputs a relay contact signal when the inverter issues an alarm and stops the inverter output. • The alarm stop state is reset by pressing the PRG/RESET key or by the digital input signal RST.	
	Alarm relay output (for any fault)	• The relay signal is output when the inverter stops upon an alarm. • PRG/RESET key is used to reset the alarm stop state.	
	Light-alarm (warning)	Below items can be registered as minor errors Alarm detection: Overheating of the heatsink (OH1), External alarm (OH2), Inverter overheat (OH3), Overheating of braking resistor (dbH), Motor overload (OL1 to OL4), Optional communication error (Er4), Option error (Er5), RS-485(port1) communication error (Er8), Inconsistent speed (excessive speed deviation) (ErE), Positioning Control Error(Ero), RS-485 (port2) communication error (ErP), Warning output: DC fan lock detected, Overload early warning (for motor), heatsink overheat early warning, Life early warning (DC link bus capacitor, electrolytic capacitor on printed circuit board, cooling fan), Reference command loss detected, P D warning output, Low torque detected, Thermistor detection (PTC), Machine life (cumulative motor run time error), Machine life (number of startups error),	L - RL
	Stall prevention	• Operates when the inverter output goes beyond the instantaneous overcurrent limiting level, and avoids tripping, during acceleration and constant speed operation.	
	Retry function	• When the motor is tripped and stopped, this function automatically resets the tripping state and restarts operation.	
	Surge protection	• The inverter is protected against surge voltage intruding between the main circuit power line and ground.	
	Command loss detected	• A loss (breaking, etc.) of the frequency command is detected to output an alarm and the operation is continued at the preset frequency (set at a ratio to the frequency before detection).	
	Momentary power failure protection	• A protective function (inverter stoppage) is activated upon a momentary power failure for 15msec or longer. • If restart upon momentary power failure is selected, the inverter restarts upon recovery of the voltage within the set time.	
Environment	Installation location	• Shall be free from corrosive gases, flammable gases, oil mist, dusts, direct sunlight. (Pollution degree 2 (EC60664-1)). Indoor use only.	
	Ambient temperature	• Open type: -10 to +50°C (14 to 122°F) (-10 to +40°C(14 to 104°F) when installed side-by-side without clearance (30HP or below)) • NEMA1/NEMA12/NEMA4: -10 to +40°C(14 to 104°F)	
	Ambient humidity	• 5 to 95% RH (without condensation)	
	Altitude	• Lower than 3300ft (1,000m)	
	Atmospheric pressure	• 86 to 106kPa	
	Vibration	• EQ7-2100-C, EQ7-4125-C or below • EQ7-2125-C, EQ7-4150-C or above • 3 mm: 2 to less than 9 Hz, 3 mm: 2 to less than 9 Hz • 9.8 m/s ² : 9 to less than 20 Hz, 2 m/s ² : 9 to less than 55 Hz • 2 m/s ² : 20 to less than 55 Hz, 1 m/s ² : 55	
	Storage temperature	• -25 to +65°C (-13 to 149°F)	
	Storage humidity	• 5 to 95% RH (without condensation)	

*1 Effective function in V/f control

*2 Effective function in dynamic torque vector control

*6 Effective function in vector control without speed sensor

*7 Effective function in vector control with speed sensor (PG option is necessary.)

*8 This specification does not guarantee that all single fault cases are surely detected (EN954-1/EN ISO 13849-1, Cat.3)

11.3 External Dimensions

11.3.1 Standard models

Inverter type EQ7-2XXX-C EQ7-4XXX-C		Dimensions inch (mm)														
230 V	460 V	W	W1	W2	H	H1	H2	D	D1	D2	D3	ØA				
0P5	0P5	4.33 (110)	3.78 (96)	0.24 (6)	10.24 (260)	9.69 (246)	0.28 (7)	5.2 (132)	4.45 (113)	0.75 (19)	0.12 (3)	0.24 (6)				
001	001	5.91 (150)	5.35 (136)					10.24 (260)		9.69 (246)			0.28 (7)	5.2 (132)	4.45 (113)	0.75 (19)
002	002															
003	003															
005	005	8.66 (220)	7.72 (196)	0.24 (6)	10.24 (260)	9.69 (246)	0.28 (7)	5.2 (132)	4.45 (113)	0.75 (19)	0.12 (3)	0.24 (6)				
007	007															
010	010															
015	015															
020	020	9.84 (250)	8.9 (226)	0.24 (6)	10.24 (260)	9.69 (246)	0.28 (7)	5.2 (132)	4.45 (113)	0.75 (19)	0.12 (3)	0.24 (6)				
025	025															
030	030															
040	040															
050	050	12.6 (320)	9.45 (240)	0.39 (10)	21.65 (550)	20.87 (530)	0.47 (12)	10.04 (255)	4.53 (115)	5.51 (140)	0.16 (4)	0.39 (10)				
060	075															
—	100	13.98 (355)	10.83 (275)	0.39 (10)	21.65 (550)	20.87 (530)	0.47 (12)	10.04 (255)	4.53 (115)	5.51 (140)	0.16 (4)	0.39 (10)				
75	125															
100																
125	—	20.87 (530)	16.93 (430)	0.59 (15)	29.53 (750)	28.35 (720)	0.61 (15.5)	11.22 (285)	5.71 (145)	5.51 (140)	0.16 (4)	0.39 (10)				
150	—															
—	150	20.87 (530)	16.93 (430)	0.59 (15)	29.53 (750)	28.35 (720)	0.61 (15.5)	11.22 (285)	5.71 (145)	5.51 (140)	0.16 (4)	0.39 (10)				
—	200															
—	250															
—	300															
—	350	26.77 (680)	11.42 (290)	0.59 (15)	39.37 (1000)	38.19 (970)	0.61 (15.5)	14.17 (360)	7.09 (180)	7.09 (180)	0.25 (6.4)	0.39 (10)				
—	450															
—	500															
—	600															
—	700	34.65 (880)	10.24 (260)	0.59 (15)	55.12 (1400)	53.94 (1370)	0.61 (15.5)	17.32 (440)	10.24 (260)	7.35 (186.8)	0.25 (6.4)	0.39 (10)				
—	800															
—	900	39.37 (1000)	11.81 (300)	0.59 (15)	61.02 (1550)	59.84 (1520)	0.61 (15.5)	19.69 (500)	12.33 (313.2)	7.35 (186.8)	0.25 (6.4)	0.39 (10)				
—	1000															

40 HP or below

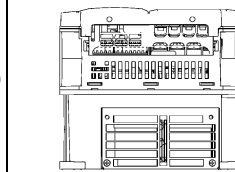
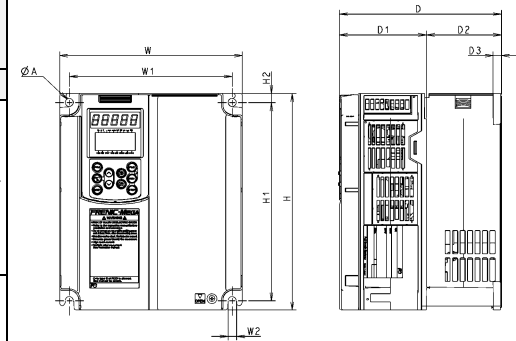

50 HP or above

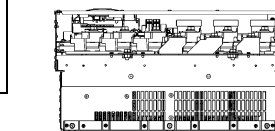
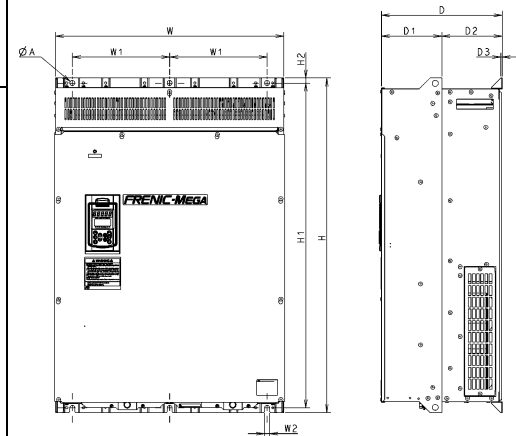

11.3.2 Panel cutting of standard model (50 HP or above)

Inverter type EQ7-2_ _ _ EQ7-4_ _ _		Refer to:	Dimensions inch (mm)									
230V	460V		W3	W4	W5	H3	H4	H5	B			
050	050	Figure A	12.28 (312)	11.34 (288)	9.45 (240)	20.87 (530)	20.16 (512)	0.35 (9)	M8			
-	060		13.66 (347)	12.72 (323)	10.83 (275)	23.43 (595)	22.72 (577)					
060	-					25.79 (655)	25.08 (637)					
-	075		10.83 (275)	28.35 (720)	27.64 (702)	27.36 (695)						
-	100											
075	-		20.08 (510)	16.93 (430)	16.93 (430)	33.46 (850)	32.48 (825)					
100	-											
-	125	Figure B	25.98 (660)	11.42 (290)	-	27.95 (710)	26.97 (685)	0.49 (12.5)	M12			
125	-											
150	-	Figure A	20.08 (510)	16.93 (430)	16.93 (430)	38.19 (970)	37.2 (945)					
-	150					Figure B	25.98 (660)	11.42 (290)		53.94 (1370)	53.07 (1348)	0.43 (11)
-	200											
-	250											
-	300	Figure C	34.02 (864)	10.24 (260)	-	59.84 (1520)	58.66 (1490)	0.57 (14.5)				
-	350											
-	450											
-	500											
-	600	Figure B	26.14 (664)	11.81 (300)	-	59.84 (1520)	58.66 (1490)	0.57 (14.5)				
-	700											
-	800											
-	900											
-	1000	Figure C	38.58 (980)	11.81 (300)	-	59.84 (1520)	58.66 (1490)	0.57 (14.5)				
-	1000											

Figure A

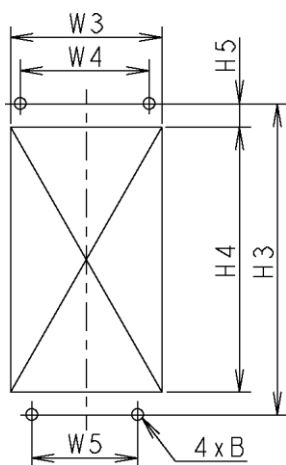

Figure B

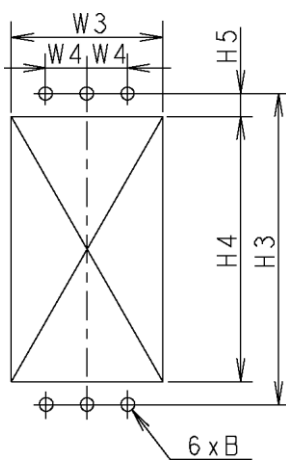
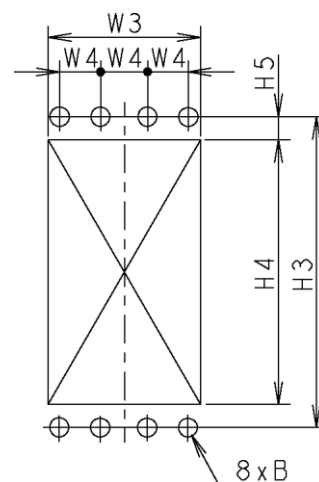

Figure C



11.3.3 DC reactor (DCR)

Power supply voltage	Inverter type EQ7-2_--- EQ7-4_---	Option/ Standard	Reactor	Refer to:	Dimensions inch (mm)									Mass lb (kg)
					W	W1	D	D1	D2	D3	H	Mounting hole	Terminal hole	
230 V	P50	Option	DCR2-0.4	Fig.A	2.6 (66)	2.2 (56)	3.54 (90)	2.83 (72)	0.59 (15)	3.7 (94)	0.2x0.31 (5.2x8)	M4	0.04 (1)	
	001		DCR2-0.75						0.79 (20)				0.06 (1.4)	
	002		DCR2-1.5						0.06 (1.6)					
	003		DCR2-2.2		3.39 (86)	2.8 (71)	3.94 (100)	3.15 (80)	0.39 (10)	4.33 (110)	0.24x0.35 (6x9)	0.07 (1.8)		
	005		DCR2-3.7						0.79 (20)			0.1 (2.6)		
	007		DCR2-5.5		4.37 (111)	3.74 (95)	3.94 (100)	3.15 (80)	0.91 (23)	5.12 (130)	0.28x0.43 (7x11)	M5	0.14 (3.6)	
	010		DCR2-7.5						0.94 (24)				0.15 (3.8)	
	015		DCR2-11						5.39 (137)				0.17 (4.3)	
	020		DCR2-15		5.75 (146)	4.88 (124)	4.72 (120)	3.78 (96)	0.59 (15)	7.09 (180)	M8	0.23 (5.9)		
	025		DCR2-18.5						0.98 (25)			0.29 (7.4)		
	030	DCR2-22A	0.3 (7.5)											
	040	DCR2-30B	Fig.B	5.98±0.12 (152±3)	3.54±0.04 (90±1)	6.14±0.12 (156±3)	4.57±0.08 (116±2)	4.53 (115)	3.07±0.2 (78±5)	5.12 (130)	0.31 (8)	M10	0.47 (12)	
	050	DCR2-37C	Fig.C	8.27±0.39 (210±10)	7.28 (185)	3.98±0.08 (101±2)	3.19 (81)	4.92 (125)	1.99±0.04 (50.5±1)	4.92 (125)	M6		0.29 (7.4)	
	060	DCR2-45C				4.17±0.08 (106±2)	3.39 (86)	5.31 (135)	2.09±0.04 (53±1)			0.33 (8.4)		
	075	DCR2-55C				3.78±0.08 (96±2)	2.99 (76)	5.51 (140)	1.89±0.04 (48±1)			5.71 (145)	0.4 (10.2)	
	100	DCR2-75C				4.17±0.08 (106±2)	3.39 (86)	5.71 (145)	2.09±0.04 (53±1)			5.71 (145)	M12	25 (11.4)
	125	DCR2-90C	4.57±0.08 (116±2)	3.78 (96)	6.1 (155)	2.28±0.04 (58±1)	31 (14)							
	150	DCR2-110C	11.81±0.39 (300±10)	10.43 (265)	4.57±0.16 (116±4)		3.54 (90)	7.28 (185)	6.3 (160)	M8	37 (17)			

Note: 100 HP or above type comes with a DC reactor (DCR) suitable for the LD-mode use.

Power supply voltage	Inverter type EQ7-2_--- EQ7-4_---	Option/ Standard	Reactor	Refer to:	Dimensions inch (mm)									Mass lb (kg)			
					W	W1	D	D1	D2	D3	H	Mounting hole	Terminal hole				
460 V	F50	Option	DCR4-0.4	Figure A	2.6 (66)	2.2 (56)	3.54 (90)	2.83 (72)	0.59 (15)	-	3.7 (94)	0 2×0.31 (5.2×8)	M4	0.04 (1)			
	001		DCR4-0.75						0.79 (20)					0.06 (1.4)			
	002		DCR4-1.5						0.06 (1.6)								
	003		DCR4-2.2		3.39 (86)	2.8 (71)	3.94 (100)	3.15 (80)	0.59 (15)	4.33 (110)	0.24×0.35 (6×9)	-	5.12 (130)	-	M5	0.08 (2)	
	005		DCR4-3.7						0.79 (20)							0.1 (2.6)	
	007		DCR4-5.5						0.94 (24)							0.17 (4.2)	
	010		DCR4-7.5		4.37 (111)	3.74 (95)	4.72 (120)	3.78 (96)	0.59 (15)	6.61 (168)	0.28×0.43 (7×11)	-	6.73 (171)	-	M6	0.17 (4.2)	
	015		DCR4-11		0.98 (25)	0.17 (4.3)											
	020		DCR4-15		5.75 (146)	4.88 (124)			0.59 (15)							0.23 (5.9)	
	025		DCR4-18.5		Standard	DCR4-22A	Figure B	5.98±0.12 (152±3)	3.54±0.04 (90±1)	6.18±0.12 (157±3)	4.53±0.08 (115±2)	4.33 (110)	3.07±0.2 (78±5)	5.12 (130)	0.31 (8)	M8	0.51 (13)
	030		DCR4-30B			4.33 (110)						0.29 (7.4)					
	040		DCR4-37C			4.13 (105)						0.33 (8.4)					
	050		DCR4-45C			3.19 (81)		4.92 (125)	M6	5.71 (145)	M10	0.41 (10.3)					
	060		DCR4-55C			3.39 (86)						0.27 (6.9)					
	075		DCR4-75C			4.72 (120)						0.41 (10.3)					
	100	DCR4-90C	2.99 (76)	4.92 (125)		M8		5.71 (145)	M12	0.27 (6.9)							
	125	DCR4-110C	4.92 (125)							0.41 (10.3)							
	150	DCR4-132C	4.72 (120)							0.27 (6.9)							
	200	DCR4-160C	3.39 (86)	4.92 (125)		M10		5.71 (145)	M12	0.27 (6.9)							
	250	DCR4-200C	4.92 (125)							0.41 (10.3)							
	300	DCR4-220C	4.72 (120)							0.27 (6.9)							
	350	DCR4-280C	4.92 (125)	4.92 (125)		M10		5.71 (145)	M12	0.27 (6.9)							
	450	DCR4-355C	4.92 (125)							0.41 (10.3)							
	500	DCR4-400C	4.72 (120)							0.27 (6.9)							
	600	DCR4-450C	3.39 (86)	4.92 (125)	M10	5.71 (145)	M12	0.27 (6.9)									
	700	DCR4-500C	4.92 (125)					0.41 (10.3)									
	800	DCR4-630C	4.72 (120)					0.27 (6.9)									
	900	DCR4-710C	4.92 (125)	4.92 (125)	M12	5.71 (145)	M12	0.27 (6.9)									
	1000	DCR4-710C	4.72 (120)					0.27 (6.9)									

Note: 100 HP or above type comes with a DC reactor (DCR) suitable for the LD-mode use.

Figure A

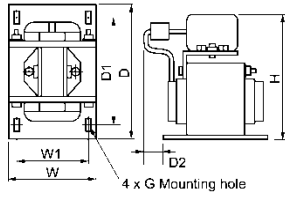

Figure B

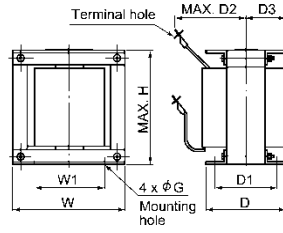

Figure C

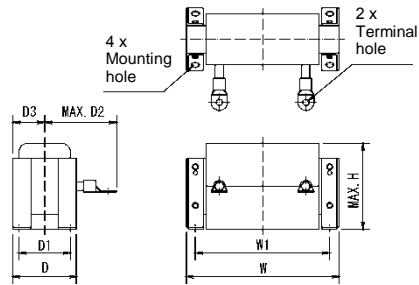

Figure D

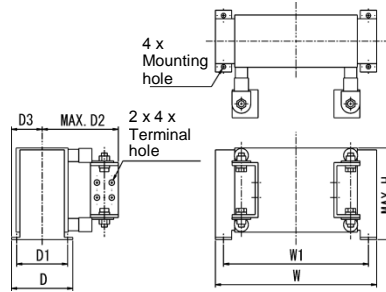
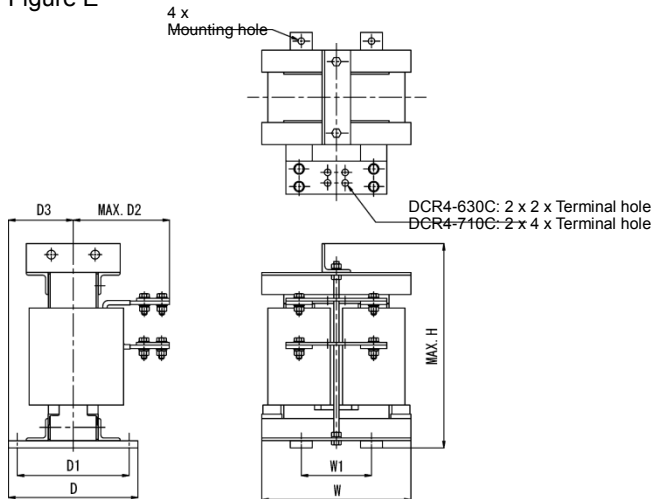

Figure E



11.3.4 Standard models with NEMA1 kit (option)

Inverter type EQ72_ ___ / EQ74_ ___		Dimensions inch (mm)		
230 V	460 V	W	H	D
0P5	0P5	4.45 (113)	12.2 (310)	5.26 (133.5)
001	001			5.76 (146.3)
002	002			5.76 (146.2)
003	003			
005	005			
007	007	8.66 (220)	13.24 (336.2)	7.68 (195)
010	010			
015	015			
020	020			
025	025	9.84 (250)	19.27 (490)	7.68 (195)
030	030		22.05 (560)	
040	—		19.27 (490)	
—	040	—	—	—
050	050	12.73 (323.4)	26.97 (685)	10.04 (255)
060	—	14.11 (358.4)	29.92 (760)	10.63 (270)
—	060	12.73 (323.4)	26.97 (685)	10.04 (255)
075	—	14.11 (358.4)	34.84 (885)	10.63 (270)
—	075		29.92 (760)	
100	—		34.84 (885)	
—	100		32.28 (820)	
125	—	21 (533.4)	37.8 (960)	11.22 (285)
—	125	14.11 (358.4)	34.84 (885)	10.63 (270)
150	—	26.91 (683.4)	46.46 (1180)	14.17 (360)
—	150	21 (533.4)	35.43 (900)	12.4 (315)
—	200		49.61 (1260)	14.17 (360)
—	250			
—	300			
—	350	26.91 (683.4)	51.18 (1300)	17.39 (441.6)
—	450	26.94 (684.2)	63.78 (1620)	
—	500	34.81 (884.2)	64.17 (1630)	17.39 (441.6)
—	600			
—	700	39.54 (1004.2)	64.57 (1640)	19.75 (501.6)
—	800			
—	900	39.54 (1004.2)	64.57 (1640)	19.75 (501.6)
—	1000			

40 HP or below

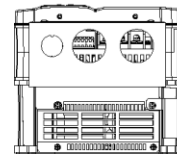
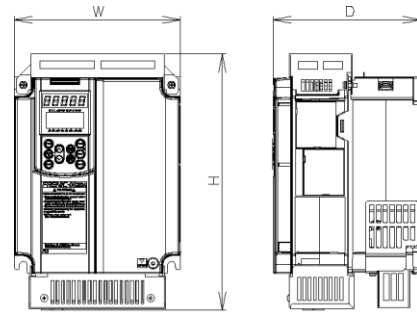

50 HP or above

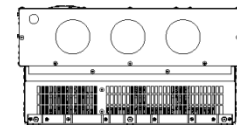
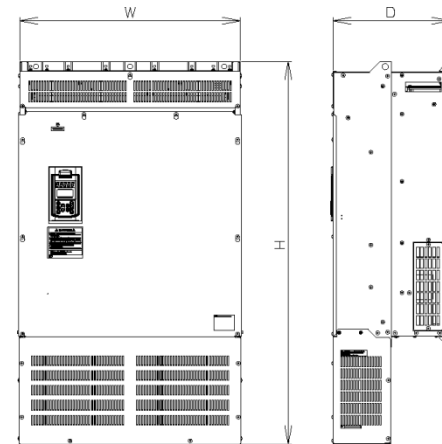

Note: Standard models with NEMA1 kit cannot employ external cooling.

11.3.5 Keypad (TP-G1W-J1)

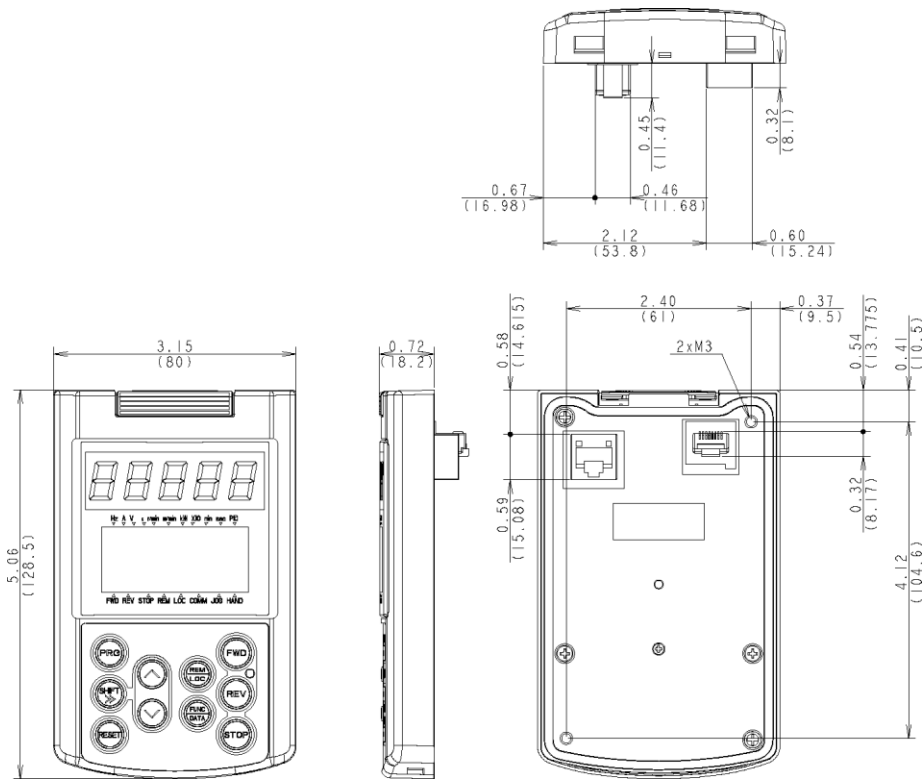

Drill four screw holes and cut a square hole in a panel as specified below.

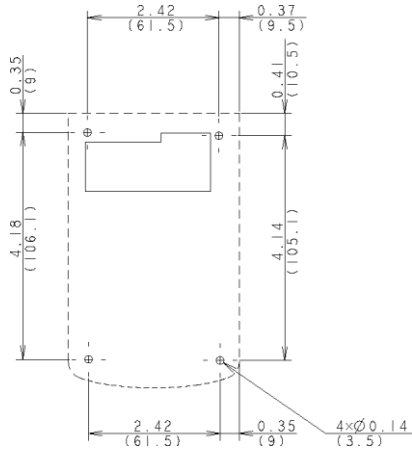

Location of Screw Holes in Panel (viewed from back)

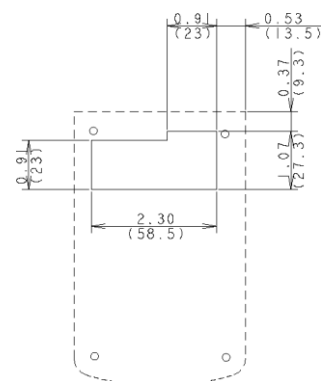

Dimensions of Panel Cutting